

AURORA

REMOTE DISPLAYS

INSTALLATION & TECHNICAL MANUAL



WESTERN SCALE CO. LTD.

**AURORA 45 - AURORA 65 - AURORA 45 SL
SUPER BRIGHT REMOTE DISPLAYS
INSTALLATION & TECHNICAL MANUAL**

SOFTWARE RELEASE 2.0, 01/2006

Copyright © 2005, 2006 **Western Scale Co. Limited**. All rights reserved.

Published by: **Western Scale Co. Limited**.

Information in this *Installation / Technical Manual* is subject to change without notice due to correction or enhancement. The information described in this manual is the property of Western Scale Co. Ltd. No part of this manual may be reproduced or retransmitted in any form, without the expressed written permission of Western Scale Co. Ltd.

Western Scale Co. Limited

1670 Kingsway Avenue
Port Coquitlam, B.C.
Canada
V3C 3Y9

Tel: (604) 941-3474

Fax: (604) 941-4020

www.westernscale.ca

info@westernscale.ca

**FOR TECHNICAL SUPPORT REGARDING THIS PRODUCT, PLEASE CALL
YOUR AUTHORIZED WESTERN DEALER:**

TABLE OF CONTENTS

INTRODUCTION 2
DISCLAIMER..... 2
AURORA FEATURES 3
DISPLAY..... 4

INSTALLATION 4
PRE-INSTALLATION 4
OPENING THE AURORA ENCLOSURE (UNMOUNTED)..... 5
REMOVING THE ELECTRONICS CARRIAGE 5
MOUNTING INSTRUCTIONS 6
OPENING THE AURORA ENCLOSURE (MOUNTED)..... 8
LOWERING THE ELECTRONICS PLATE 9
REMOVE THE ELECTRONICS CARRIAGE 9

WIRING..... 10
POWER WIRING..... 10
COMMUNICATIONS WIRING 11
Communication Input Jumper 11
RS 232 Wiring 11
RS 232 Daisy Chain 12
RS 422 Wiring 12
RS 485 Multi-Drop Wiring..... 12
20 mA Current Loop Wiring..... 13
20 mA Current Loop Mode Switch 13

START-UP..... 14
POWER UP 14
RESET BUTTON 14
AUTO-LEARN..... 14
LEARN BUTTON..... 14
DIAGNOSTIC INDICATOR LIGHTS 15

CONFIGURATION & OPTIONS 16
CONFIG SWITCHES..... 16
Switches 1 & 2: Daytime Brightness 16
Switches 3 & 4: Nighttime Brightness 16
Switch 5: Mirror Display Mode..... 17
Switch 6: Start-up Auto-Learn 17
Switch 7: Reserved for Future Use 17
Switches 8 & 9: Multi-Drop ID 17
OPTIONS SWITCHES 18
Switches 1, 2, 3, & 4: Utility Program Select..... 18
Switch 5: Power-Save Mode 18
Switch 6: Leading Zeros..... 19
Switches 7, 8, & 9: Radio Channel Select..... 19

TRAFFIC LIGHT CONTROL..... 20
EXTERNAL TRAFFIC LIGHTS 20
BUILT-IN TRAFFIC LIGHT 21

AURORA UTILITY PROGRAMS 22

WIRELESS SET-UP..... 26
AURORA REMOTE DISPLAY 26
INDICATOR & BASESTATION 27
Wireless Connection Test 27
BASESTATION SET-UP 28
Select the Radio Channel..... 29
Set the Baud Rate 30

TROUBLESHOOTING & ERROR MESSAGES..... 31

INTRODUCTION

The Aurora Remote Display Series is the latest development from Western, the company which first brought LED remote displays to the weighing industry in the 1980s.

New technologies, materials, and construction methods have allowed a remarkable evolution in remote displays, making them more affordable, easier to read, and a vital part of any scale system. Aurora Remote Displays incorporate the most standard features of any weighing display, making it the best choice for virtually any application.

Like all Western products, Aurora Remote Displays are designed with durability, functionality, and versatility in mind. Users are assured that Aurora Remote Displays meet the specified local Weights & Measures regulations for anywhere in North America.

Western: Engineered for the diversity of the weighing industry.

DISCLAIMER

The following information is for the exclusive use of **WESTERN** Dealers and Customers.

Since Aurora Remote Displays are a valuable component of your weighing system, installation and configuration procedures (as described in this manual) should only be carried out by qualified Scale Service Technicians as authorized by Western.



Scale Service Technicians handling Aurora PCBs must observe proper electrostatic discharge (ESD) handling procedures.



CAUTION! HIGH VOLTAGES are present inside the Aurora enclosure.



ATTENTION! Unauthorized installation and service of this unit may void the warranty.

AURORA FEATURES

HIGH VISIBILITY

- A bigger, brighter display (4.5 or 6.5 inches high) makes the Aurora easy to read over wide viewing angles, in foul weather, and in direct sunlight.

EASY TO INSTALL & USE

- Auto-Learn Technology interprets the data format and output string of any scale indicator, reducing set-up time.
- The Drop-down electronics carriage makes installation and service quick and easy.

WIRELESS COMMUNICATIONS

- Go wireless. Make installation easy and use remote displays where you never thought possible.
- The integrated radio option allows communications over several thousand feet.
- No external housings or radio knowledge required.

SAVE ENERGY

- Ultra-efficient LED technology is the smart choice for power conscious users.
- The photo sensor automatically adjusts LED intensity for efficient day or night viewing.
- Power Save Mode reduces power consumption during long periods of inactivity.

MORE...

- A ready to use, built-in traffic light (Aurora 45 SL model only).
- Selectable brightness levels.
- Built-in relay remotely controls traffic lights.
- Built-in utility programs for axle weighing, traffic light control, etc.
- Mirrored Display Mode.
- Multi-drop communications.

DISPLAY

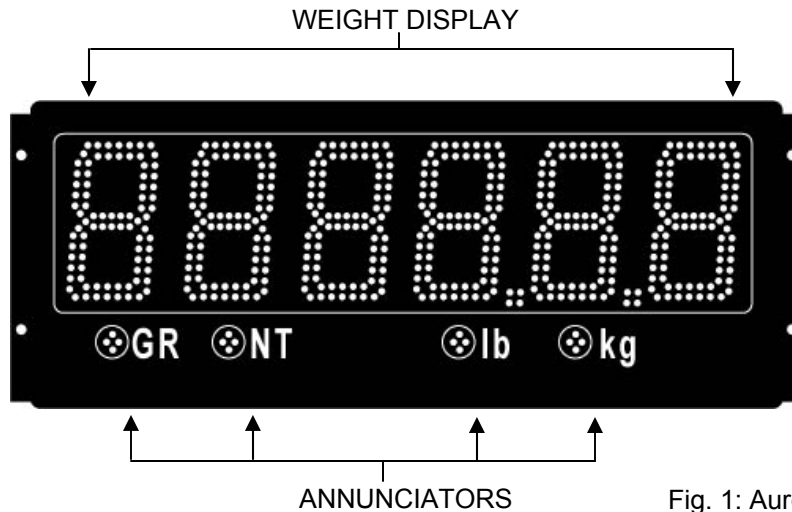

Fig. 1: Aurora 45 Display

WEIGHT DISPLAY: 6 LED digits (7 segments). Up to 2 decimal places.

ANNUNCIATORS: GR = Gross Weighing Mode
NT = Net Weighing Mode
lb = Pounds
kg = Kilograms

INSTALLATION

PRE-INSTALLATION (Receiving Inspection)

It is always good practice to verify that the Aurora Remote Display is complete and undamaged upon receipt.

- Check over packaging for any signs of damage.
- Remove the Aurora Remote Display from its protective packaging and check for damage.
- Verify that the shipment includes:
 - Aurora Remote Display (complete and intact, with power cord).
 - Aurora Installation / Technical Manual.
- Auroras ordered with the Wireless option should include:
 - Radio Module.
 - External Antenna.
 - Internal Antenna Cable.
 - BaseStation kit including software and 2 interface cables.

OPENING THE AURORA ENCLOSURE (UNMOUNTED)

1. When opening an Aurora prior to mounting, place the unit top-down on a smooth, flat, surface.
2. Make sure the unit is disconnected from power.
3. Remove the captive screws from the bottom of the enclosure.
4. Angle the Electronics Carriage so the tabs are at opposite corners of the Main Enclosure opening.
5. Guide the Electronics Carriage out of the Main Enclosure, being careful to avoid bending any LED leads. Each LED is mounted very close to the PCB to prevent bending.
6. Place the Electronics Carriage bottom-down on the flat surface as illustrated (As seen in Fig. 2).

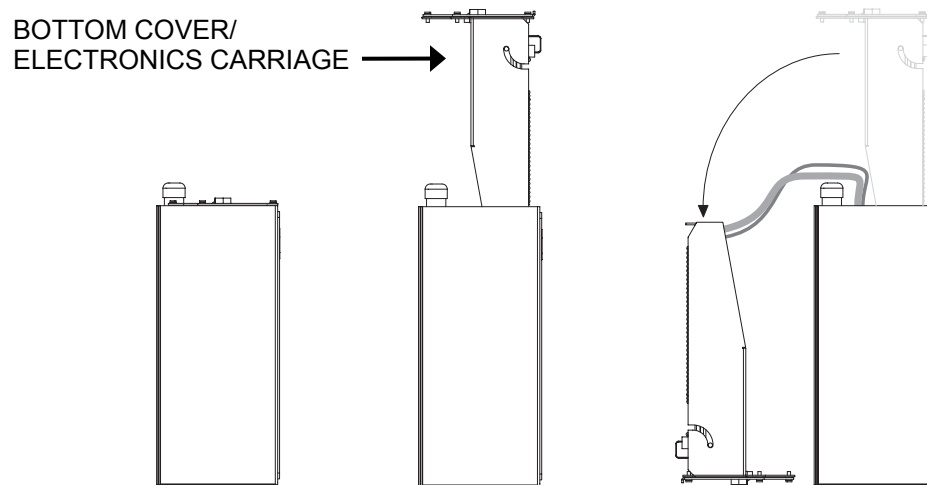

Fig. 2: Open Aurora (side)

REMOVING THE ELECTRONICS CARRIAGE

1. Once the Electronics Carriage has been removed from the Main Enclosure, disconnect the AC power and ground connections from the Power Supply board.
2. Disconnect the green ground wire from the Electronics Carriage frame.

MOUNTING INSTRUCTIONS

1. Inspect the installation site for properly grounded power.
2. Ensure that mounting structures (walls, pole brackets, etc.) will bear the weight of the display (Aurora 45: 20 lbs, Aurora 65 & 45SL: 32 lbs).
3. Allow proper clearance for lowering and removing the Electronics Carriage.
4. Use proper hardware, including wall anchors where necessary, when mounting the enclosure. Secure the Main Enclosure to wall or pole mounted bracket with 5/16ths bolts.
5. Run power and communication cables into the enclosure via strain reliefs (as required).



NOTE: The Electronics Carriage may be removed to reduce weight when installing.

Wall Mounting

Hole patterns for the Aurora Remote Displays are given in the diagram below:

Aurora 45:

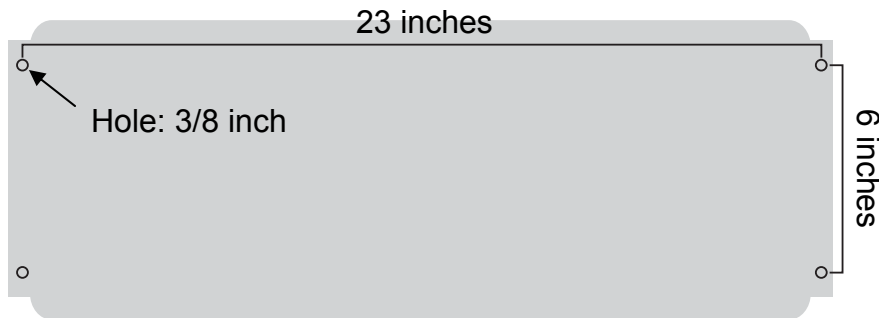

Aurora 65 & Aurora 45 SL:

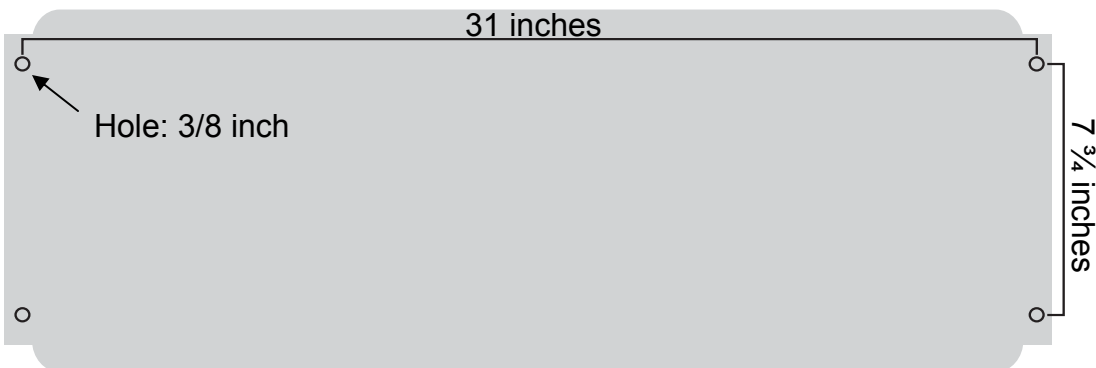

Fig. 3: Hole patterns

Pole Mounting Bracket

1. Select appropriate height and fasten the small “C” bracket to the pole using the mounting clamps provided.
2. Fasten the larger “C” bracket to the small “C” bracket using the hardware provided.
3. Fasten the Aurora display to the Pole Mounting Bracket as outlined in the Mounting Instructions (See Fig. 4).



NOTE: The Pole Mounting Bracket allows for poles or beams from up to 8 inches in diameter.

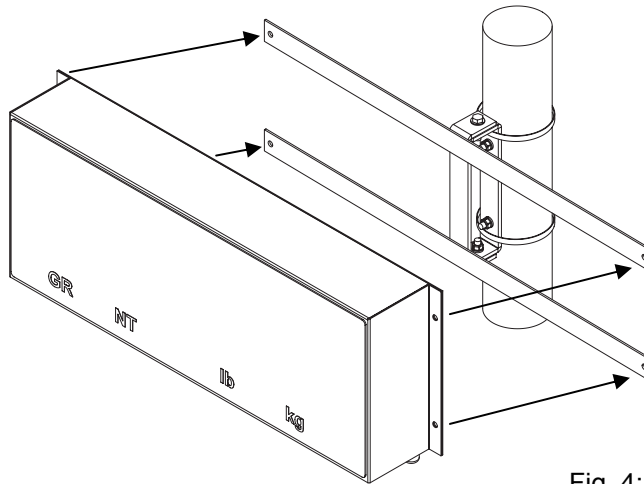

Fig. 4: Pole Mounting Bracket

Visor Option

1. Loosen the mounting hardware on the Aurora Main Enclosure 1/8th inch.
2. Rest the Visor's mounting brackets on the bolt between the bolt head and the front of the Aurora's side mounting plates.
3. Re-tighten the mounting hardware.

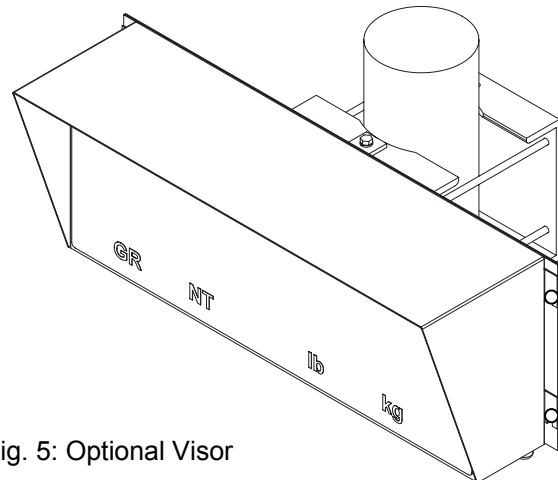

Fig. 5: Optional Visor

OPENING THE AURORA ENCLOSURE (MOUNTED)

1. Make sure the unit is disconnected from power.
2. Remove the captive screws from the bottom of the enclosure.
3. Slowly, guide the Electronics Carriage out of the Main Enclosure, being careful to avoid bending any LED leads. Each LED is mounted very close to the PCB to prevent bending.
4. The Electronics Carriage has tabs on either end that allow it to rest on the Main Enclosure's flange when mounted (As seen in Fig. 6 & 7).

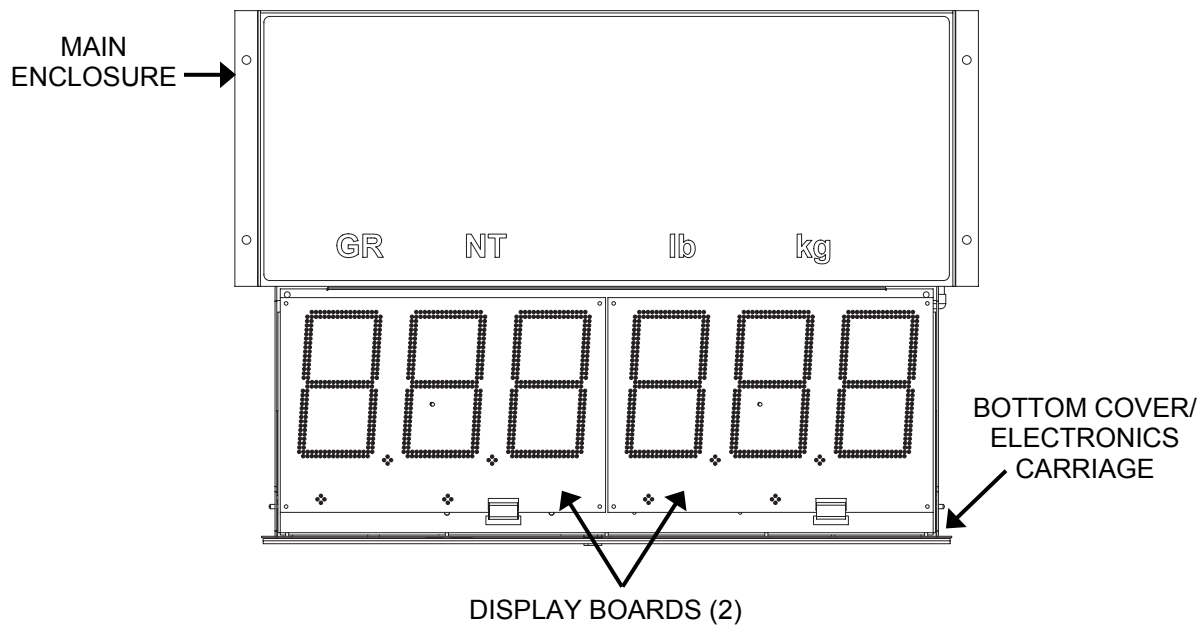

Fig. 6: Front View

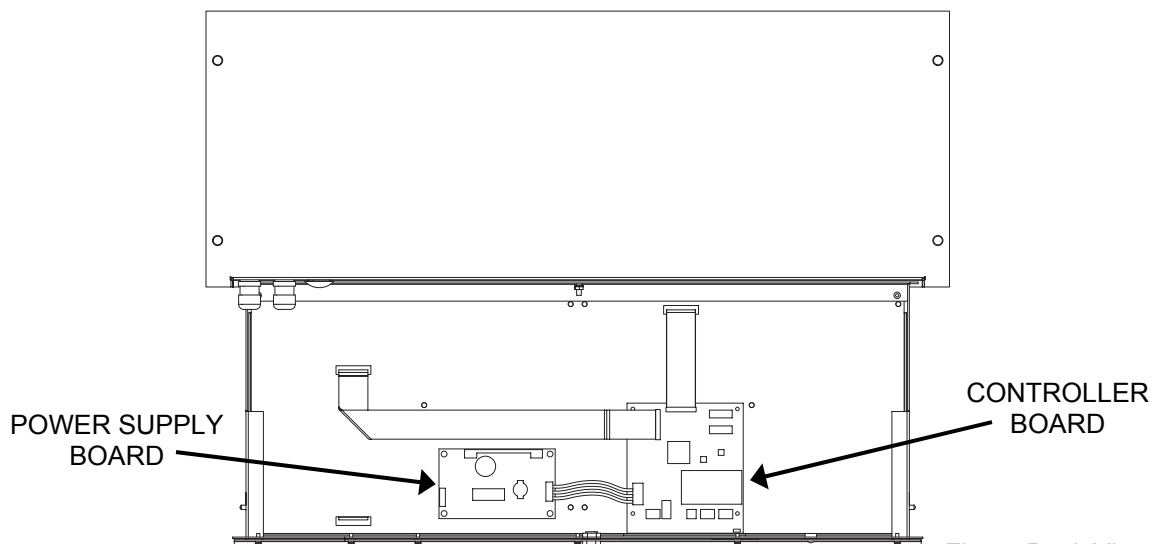

Fig. 7: Back View

LOWERING THE ELECTRONICS PLATE

1. Remove the two (2) captive screws holding the Electronics Plate to the Electronics Carriage.
2. Slowly, allow the Electronics Plate to swing down, making access easier for wiring and service (As seen in Fig. 8).

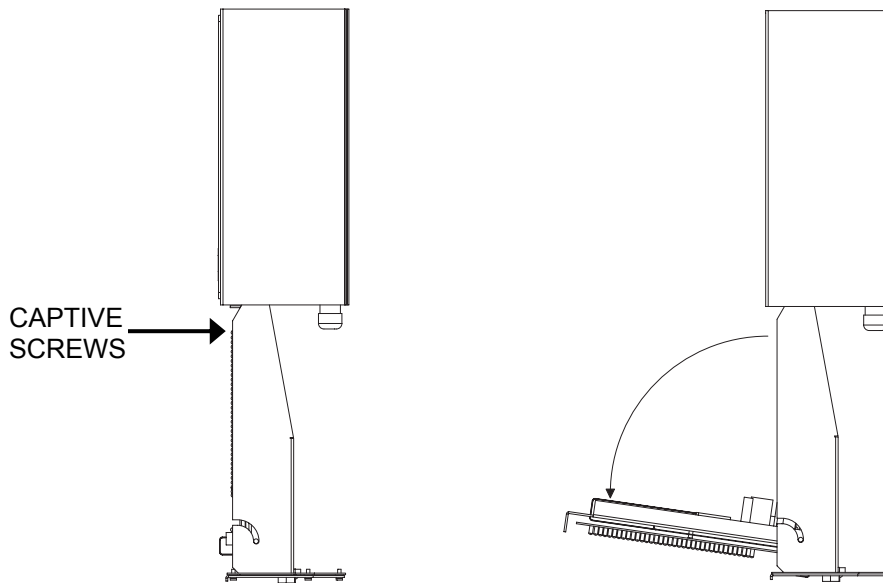

Fig. 8: Side View

REMOVE THE ELECTRONICS CARRIAGE

1. Once the Electronics Carriage has been lowered from the Main Enclosure, disconnect the AC power and ground connections from the Power Supply board.
2. Disconnect the green ground wire from the Electronics Carriage frame.
3. Angle the Electronics Carriage so the tabs are at opposite corners of the Main Enclosure opening.
4. Guide the Electronics Carriage free of the Main Enclosure.

WIRING

POWER WIRING

Aurora Remote Displays are wired for power at the factory. The factory supplied power cable can be removed for direct AC wiring if necessary.



CAUTION! HIGH VOLTAGE! Only trained personnel should attempt this procedure.



ATTENTION! AC wiring must be terminated at the AC Power Terminal Block, not directly at the Power Supply board.

1. Ensure the unit is disconnected from power and open the enclosure. Detach the Electronics Carriage to free up space.
2. Loosen the standoff nuts and remove the Terminal Block from the mounting posts.
3. Disconnect the factory supplied power cord from the Terminal Block and Grounding Post. Do not remove the Internal Ground Wire.
4. Loosen the strain relief and pull the power cord through. Run the new power cable through the strain relief. Leave about 6 inches of wire to work with and tighten the strain relief.
5. Connect the new GROUND wire to the Grounding Post and tighten nut. The Internal Ground Wire runs from the Grounding Post to Pin 1 on the Terminal Block.
6. Wire the new power cable to the Terminal Block. See table below:

| AC POWER | TO TERMINAL BLOCK |
|-----------------|--------------------------|
| HOT (+) | PIN 3 |
| NEUTRAL (-) | PIN 2 |
| GROUND (GND) | PIN 1 |

7. Replace the Terminal Block and fasten on mounting posts.
8. Ensure that the Internal Power Cable is connected to the Power Supply board. Please see Figure 9: Power Wiring.

POWER WIRING (Continued)

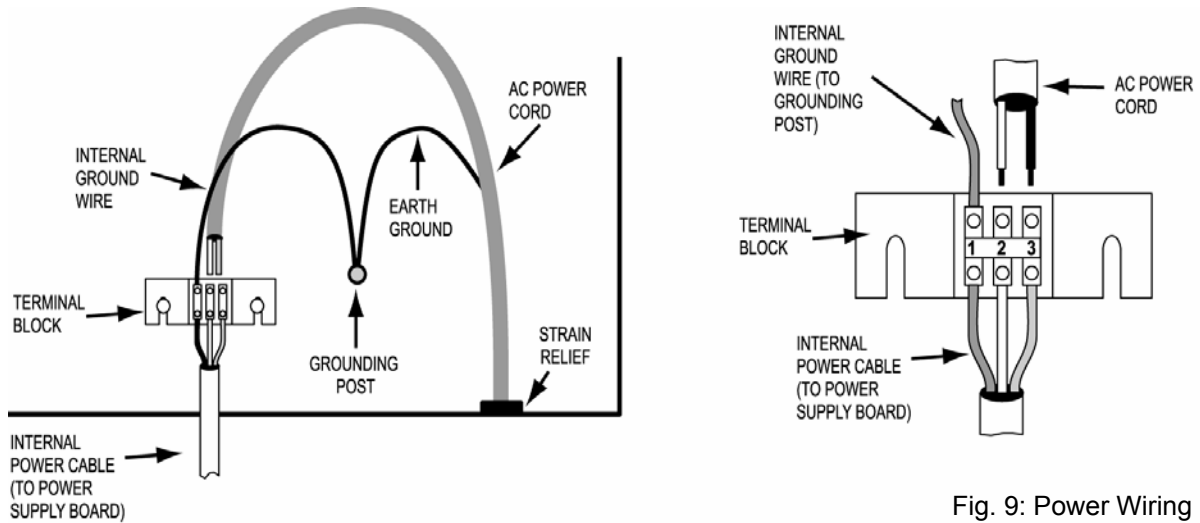

Fig. 9: Power Wiring

COMMUNICATIONS WIRING

All communications wiring terminates at the Controller board. Communications should be wired before applying power to the unit if possible.

Communication Input Jumper

A communications input type (RS 232, RS 422/485, or 20 mA Loop) must be selected by placing the jumper on the appropriate pins.

INPUT SELECT

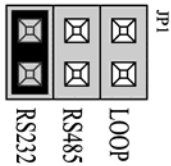

RS 232

INPUT SELECT

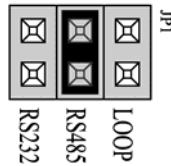

RS 422/485

INPUT SELECT

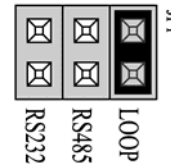

20mA Current Loop

Fig. 10: Jumper Positions

RS 232 Wiring

1. Set the Communication Input Jumper (JP 1) to **RS232**.
2. Terminate the indicator's communication wires at the RS 232 terminal (J3). See table below:

| INDICATOR | TO AURORA REMOTE DISPLAY |
|---------------------|--------------------------|
| TRANSMIT (TX) | RECEIVE (RX) |
| RECEIVE (RX) | NO CONNECTION |
| SIGNAL GROUND (GND) | SIGNAL GROUND (SIG GND) |

RS 232 Daisy Chain

| INDICATOR | TO AURORA 1 | TO AURORA 2 |
|-----------|-------------|-------------|
| TX | RX | |
| RX | TX | RX |
| GND | GND | GND |
| | | Etc... |

RS 422 Wiring

1. Set the Communication Input Jumper (JP 1) to **RS485**.
2. Terminate the indicator's communication wires at the RS 485 terminal (J4). See table below:

| INDICATOR | TO AURORA REMOTE DISPLAY |
|-------------------|--------------------------|
| TRANSMIT A (TX A) | RECEIVE A (RX A) |
| TRANSMIT B (TX B) | RECEIVE B (RX B) |

RS 485 Multi-Drop Wiring

1. Set the Communication Input Jumper (JP 1) to **RS485**.
2. Terminate the indicator's communication wires at the RS 485 terminal (J4) using one of the following methods:

Parallel Multi-drop wiring

| SCALE CONTROLLER | TO AURORA 1 | TO AURORA 2 | TO AURORA 3 | ETC. |
|------------------|-------------|-------------|-------------|------|
| TX A | RX A | RX A | RX A | RX A |
| TX B | RX B | RX B | RX B | RX B |

Split Multi-Drop Wiring

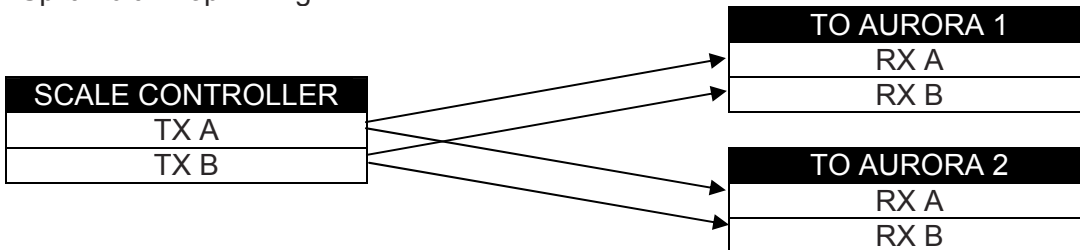

NOTE: Multi-Drop IDs are set using the CONFIG Dip-switches. For settings, see Switches 8 & 9: Multi-Drop ID, on page 17.

20 mA Current Loop Wiring

1. Set the Communication Input Jumper (JP 1) to **LOOP**.
2. Terminate the indicator's communication wires at the 20 mA Current Loop terminal (J5). See table below:

| INDICATOR | TO AURORA REMOTE DISPLAY |
|------------|--------------------------|
| 20 mA TX + | RECEIVE POSITIVE (RX +) |
| 20 mA TX - | RECEIVE NEGATIVE (RX -) |

20 mA Current Loop Mode Switch

- After the current loop is wired, ACTIVE or PASSIVE mode must be selected (SW 10) on the Controller board.
- Select Active mode if the Aurora is required to supply the current to the communicating device.
- Select Passive mode if the communicating device (indicator) supplies the current to the Aurora.
- If unsure of these requirements, check the device's manual.

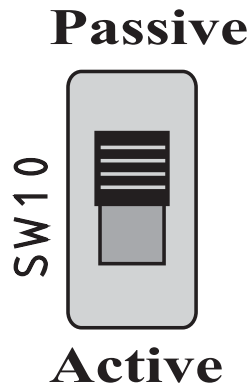

Fig. 11: 20 mA Mode Switch

START-UP

POWER UP

- The Aurora has no ON/OFF button or switch. Plugging the unit into AC power will turn the unit ON.
- Disconnecting AC power will turn the unit OFF.

RESET BUTTON

- The RESET button on the Controller board allows the Technician to cycle power on the unit without disconnecting/connecting AC power.

AUTO-LEARN

- On power up, the Aurora automatically enters Auto-Learn Mode, analyzing the serial communications and string type.
- The indicator's output string must contain number characters. An STX character (ASCII 02) and/or CR character (ASCII 13) must also be included.
- Once Auto-Learn is successful (about 10 seconds after power up) the Aurora will display the current weight.



NOTE: Automatic Start-up Auto-Learn may be disabled for custom applications. See Switch 6: Start-up Auto-Learn, on page 17.

LEARN BUTTON

- If Automatic Start-up Auto-Learn is disabled, the LEARN button on the Controller board must be pressed to enter Auto-Learn Mode.

DIAGNOSTIC INDICATOR LIGHTS

The Aurora has 3 diagnostic indicator lights located on the Controller board.

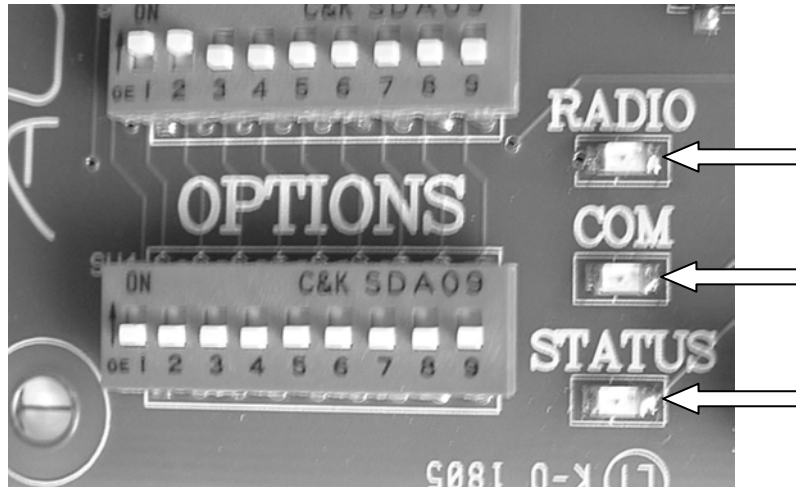

Fig. 12: Indicator Lights

STATUS Light:

- The Aurora's "heartbeat". **BLINKS** when power is applied to the unit.
- Regular blinking (Once per second) indicates that the Aurora has successfully learned a data string and is running properly.
- Rapid blinking (3 times per second) indicates that the Aurora is in Auto-Learn mode, attempting to interpret a data string.

COM Light:

- **FLASHES ON** each time the Aurora receives a character through any of its COM Ports (including the radio).

RADIO Light:

- **FLASHES ON** when the Aurora's Radio Module receives data.
- This light will only illuminate if the Radio Module is installed.

CONFIGURATION & OPTIONS

The Aurora uses two banks of Dip Switches on the Controller board (SW 3 & SW 4) to set-up the configuration and options.



NOTE: Dip Switch settings take effect only after the Aurora has been reset (Cycle power directly or press the “RESET” button).

CONFIG SWITCHES

The “CONFIG” bank of dip switches (SW 3) is for the following features:

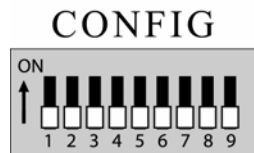

Switches 1 & 2: Daytime Brightness

There are 4 selectable brightness levels. The built-in photo sensor automatically detects daylight conditions and sets the display brightness to this level.

| BRIGHTNESS LEVEL | SWITCH 1 | SWITCH 2 |
|-------------------------|-----------------|-----------------|
| High (Default) | ON | ON |
| Medium-High | OFF | ON |
| Medium-Low | ON | OFF |
| Low | OFF | OFF |

Switches 3 & 4: Nighttime Brightness

There are 4 selectable brightness levels. The built-in photo sensor automatically detects nighttime conditions and sets the display brightness to this level.

| BRIGHTNESS LEVEL | SWITCH 3 | SWITCH 4 |
|-------------------------|-----------------|-----------------|
| High | ON | ON |
| Medium-High | OFF | ON |
| Medium-Low | ON | OFF |
| Low (Default) | OFF | OFF |



NOTE: Lowering the brightness level at night helps reduce nighttime glare and energy costs. Passing headlights, spotlights, etc. will NOT activate the daytime brightness level.

Switch 5: Mirror Display Mode

The Aurora’s digits may be mirrored for applications where the display is viewed from a vehicle’s rear-view or side-view mirrors.

| MIRROR DISPLAY MODE | SWITCH 5 |
|-------------------------------|----------|
| OFF (Default – Digits normal) | OFF |
| ON (Digits mirrored) | ON |

Switch 6: Start-up Auto-Learn

On power up, the Aurora automatically enters Auto-Learn Mode, analyzing the serial communications and string type. In certain situations, it may be necessary to disable this feature. Once disabled, the LEARN button on the Controller board must be pressed before the Aurora will go into Auto-Learn Mode.

| START-UP AUTO-LEARN | SWITCH 6 |
|---------------------|----------|
| ENABLED (Default) | OFF |
| DISABLED | ON |

Switch 7: Reserved for Future Use

Switches 8 & 9: Multi-Drop ID

Up to four (4) Aurora displays can share a serial or radio connection. Messages are sent to individual displays using control codes and these Multi-Drop IDs. For Multi-Drop instructions, see page 25.

| MULTI-DROP I.D. | SWITCH 8 | SWITCH 9 |
|-----------------|----------|----------|
| 0 (Default) | OFF | OFF |
| 1 | ON | OFF |
| 2 | OFF | ON |
| 3 | ON | ON |



NOTE: If Multi-Drop is not being used, it is very important that Switches 8 & 9 be set in the OFF position.

OPTIONS SWITCHES

The “OPTIONS” bank of dip switches (SW 4) is for the following features:

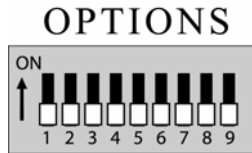

Switches 1, 2, 3, & 4: Utility Program Select

The Aurora has built-in utility programs that run in conjunction with the normal display functions.

| PROGRAM | SW 1 | SW 2 | SW 3 | SW 4 |
|--------------------------------|------|------|------|------|
| 1 – NORMAL Mode (No program) | OFF | OFF | OFF | OFF |
| 2 – Axle Weighing with Totals | OFF | OFF | ON | OFF |
| 3 – Axle Weighing (Driving On) | OFF | OFF | OFF | ON |
| 4 – COMMAND mode. | OFF | OFF | ON | ON |



NOTE: Please see the Aurora Utility Program section for program overviews (Page 22).

Switch 5: Power-Save Mode

If there is no activity on the scale for 10 minutes, the display brightness will dim one level below the selected brightness level (day or night, as applicable). The Aurora will return to the selected brightness level when motion is detected on the scale.

| POWER SAVE MODE | SWITCH 5 |
|-------------------|----------|
| ENABLED (Default) | OFF |
| DISABLED | ON |

Switch 6: Leading Zeros

In some cases, the scale indicator may transmit leading zeros in the output string. If leading zeros are NOT required, they may be suppressed. The Aurora will automatically remove the leading zeros and replace them with blank spaces on the display.

| LEADING ZEROS | SWITCH 6 |
|---------------------------------|----------|
| ENABLED (Default) | OFF |
| DISABLED (Remove Leading Zeros) | ON |



NOTE: Leading Zeros may also be disabled using the scale indicator (if possible).

Switches 7, 8, & 9: Radio Channel Select

The 900 MHz Radio Module (optional) has 6 frequency channels. If there are multiple scale/remote display installations at a given site, each installation must have its own radio channel selected.

| CHANNEL | SWITCH 7 | SWITCH 8 | SWITCH 9 |
|-------------|----------|----------|----------|
| 0 (Default) | OFF | OFF | OFF |
| 1 | ON | OFF | OFF |
| 2 | OFF | ON | OFF |
| 3 | ON | ON | OFF |
| 4 | OFF | OFF | ON |
| 5 | ON | OFF | ON |



NOTE: If the wireless connection experiences interference problems from another radio site, switching radio channels will most likely correct the problem.



NOTE: The BaseStation Radio connected to the scale indicator must be configured with the same radio channel the Aurora.

TRAFFIC LIGHT CONTROL

EXTERNAL TRAFFIC LIGHTS (Aurora 45 & 65)

External traffic lights can be switched by the Aurora’s built-in relay.

1. Wire the traffic light to the Stop Light terminal (J7) on the Controller board:

| TRAFFIC LIGHT | TO AURORA REMOTE DISPLAY |
|-------------------|--------------------------|
| HOT (+) | COMMON |
| RED NEUTRAL (-) | RED |
| GREEN NEUTRAL (-) | GREEN |



NOTE: For more information on wiring, see the manufacturer’s manual for the proper model of traffic light used.



ATTENTION! The Aurora does not supply power to the external traffic light. DO NOT supply more than **3 A at 110 VAC** to the Stop Light terminal (J7) and built-in relay.

2. The relay’s default condition is OPEN. An open contact is meant to correspond to a GREEN light.
3. The Aurora controls the traffic light using the pre-installed utility programs or serial commands (in Command Mode only).

Pre-installed Utility Programs

The following utility programs control the built-in relay for switching an external traffic light. For program overviews, see page 22.

| PROGRAM | SW 1 | SW 2 | SW 3 | SW 4 |
|--------------------------------|------|------|------|------|
| 2 – Axle Weighing with Totals | OFF | OFF | ON | OFF |
| 3 – Axle Weighing (Driving On) | OFF | OFF | OFF | ON |
| 4 – COMMAND mode. | OFF | OFF | ON | ON |

Serial Commands

When the Aurora is set in Command Mode, it will accept serial commands to switch the built-in relay for traffic light control.

For a list of serial control commands, see page 24.

BUILT-IN TRAFFIC LIGHT (Aurora 45 SL Only)

The built-in traffic light may be controlled by remote switch, the pre-installed utility programs, or serial commands (in Command Mode only).

Remote Switch

1. Wire remote switches to the Stop Light Remote Switch terminal (J2) on the back of the Stop Light Display board. The Aurora display supplies power to the switch.
2. The default condition (switch contact open) is GREEN. When the switch contact is closed, the light turns RED.



NOTE: Remote switches will be disabled if the Aurora has a program selected.

Pre-installed Utility Programs

The following utility programs control the built-in traffic light. For program overviews, see page 22.

| PROGRAM | SW 1 | SW 2 | SW 3 | SW 4 |
|--------------------------------|------|------|------|------|
| 2 – Axle Weighing with Totals | OFF | OFF | ON | OFF |
| 3 – Axle Weighing (Driving On) | OFF | OFF | OFF | ON |
| 4 – COMMAND mode. | OFF | OFF | ON | ON |

Serial Commands

When the Aurora is set in Command Mode, it will accept serial commands to switch the built-in traffic light.

For a list of serial control commands, see page 24.

AURORA UTILITY PROGRAMS

The Aurora signboard has several auxiliary functions that may be activated via the OPTIONS dipswitches on the controller board.

| PROGRAM | SW 1 | SW 2 | SW 3 | SW 4 |
|--------------------------------|------|------|------|------|
| 1 – NORMAL Mode (No program) | OFF | OFF | OFF | OFF |
| 2 – Axle Weighing with Totals | OFF | OFF | ON | OFF |
| 3 – Axle Weighing (Driving On) | OFF | OFF | OFF | ON |
| 4 – COMMAND mode. | OFF | OFF | ON | ON |

Program 1: Normal Mode - No specific program is selected.

Program 2: Axle Weighing with Totals - For use with axle scales only!

- Scale at zero – GREEN light.
- Truck drives its first axle on the scale, after motion stops – RED light. The Aurora displays the axle weight and axle number (A1).
- GREEN light – Ready for the next axle. The next axle is driven onto the scale. After motion stops – RED light. The Aurora displays the axle weight and axle number (A2). Repeat for each remaining axle.
- After the last axle (weight at or near ZERO) – RED light. The truck's total axle weight is displayed for 10 seconds (flashing).
- Scale at or near ZERO – GREEN light. Ready for the next truck.

Program 3: Axle Weighing - Driving on - For axle weighing on regular vehicle scales.

- Scale at zero – GREEN light.
- Truck drives its first axle on the scale, after motion stops – RED light. The Aurora displays and axle number (A1), then the axle weight – GREEN light.
- The next axle is driven onto the scale. After motion stops – RED light. The Aurora displays the axle number (A2), then the axle weight – GREEN light.
- This is repeated until all axles are on the scale. After motion stops – RED light. The Aurora displays the axle number (A_n), then the final axle weight – GREEN light.
- If there is no motion or significant weight change for 12 seconds, the truck's total scale weight is displayed and the truck can drive off the scale.

Program 4: COMMAND MODE

All Aurora displays can be setup to receive commands directly from the scale system or PC. Supported commands include transmitting weights, basic alphanumeric messaging, stoplight relay control, and additional display functions.

Command mode disables Auto-Learn and fixes communications at 9600-N-8-1. The Aurora looks only for specific commands sent by the indicator or scale controller.

Activating Command Mode

1. To enable command mode, OPTIONS dipswitches 1 to 4 on the Controller board must be set as follows:

| PROGRAM | SW 1 | SW 2 | SW 3 | SW 4 |
|------------------|------|------|------|------|
| 4 – COMMAND Mode | OFF | OFF | ON | ON |



REMEMBER: Switch settings do not take affect until the Aurora is reset or powered up again.

Transmit a Weight String

Use numeric ASCII characters followed by a <CR> character.

Example:

- To display “1000”, transmit: **1000<CR>**

Transmit Status Characters

Status characters may be imbedded anywhere in the weight string to control the annunciator lights. Status characters may be upper or lowercase, and in any order, before or after the weight.

| STATUS COMMAND | CHARACTER | ASCII |
|----------------|----------------------|-------|
| GROSS weight | G or g | |
| NET weight | N or n | |
| POUNDS | L or l | |
| KILOGRAMS | K or k | |

Example:

- To display 1000 lb gross, transmit: **1000LG<CR>** -or- **GL1000<CR>**

Control Commands

Control commands are single ASCII characters (followed by <CR>) that are transmitted to the Aurora to control additional features such as the built-in traffic light (Aurora 45 SL) and the traffic light relay.

| CONTROL COMMAND | CHARACTER | ASCII |
|----------------------------------|-----------|-------|
| RED light – Relay switch RED | & | 38 |
| GREEN light – Relay switch GREEN | * | 42 |
| Turn ON flashing weight display | (| 40 |
| Turn OFF flashing weight display |) | 41 |
| FLASH weight display 3 times | ! | 33 |

Alphanumeric messaging to the scoreboard

All Aurora models can display alphanumeric messages within the limits of a 7 segment digit. When a letter other than **L**, **K**, **G**, or **N** is detected, it assumes that the message is alphanumeric. All characters in the data string are then treated as an alphanumeric message, and not a weight value.

Alphanumeric messages are displayed from left to right.

Sample Command Mode Data Strings

| DATA STRING | DISPLAY |
|---------------|--------------------|
| 0 <CR> | “0” gross |
| 1000 <CR> | “1000” gross |
| LN 1234 <CR> | “1234” lb net |
| 1234 GK <CR> | “1234” kg gross |
| 1234 L g <CR> | “1234” lb gross |
| hello<CR> | “hELLO” |
| *<CR> | GREEN light |
| stop &<CR> | “StoP ”, RED light |



NOTE: Do not transmit Control Commands within a WEIGHT data string. Control Commands should only be sent alone (followed by a <CR>), or within an Alphanumeric data string.

Multi-Drop addressing

Aurora displays using Multi-drop must be in Command Mode. The Multi-drop address (0 to 3) is set using SW8 and SW9 on the CONFIG dipswitch bank (See page 17).

When using Multi-drop, the Aurora will only respond after it has been selected.

To select the display, transmit a “#” character (ASCII 35), followed by the correct ID number and a CR (ASCII 13) character. The Aurora will remain selected until it receives a command containing a different address.

Examples:

1. Select multi-drop address 1:

Transmitting “#1<CR>” selects the display with ID #1.

2. Select multi-drop address 3, then send a weight of 1000lb gross:

“#3<CR>”

“1000LG<CR>”

The ID number may be embedded with the weight string:

“#3 1000LG<CR>”

3. Send 3 different weights to 3 different scoreboards:

“#0 2000LG<CR>#1 3000LG<CR>#2 5000LG<CR>”

4. Send the text “hello” to scoreboard address 3.

“#3 HELLO<CR>”

WIRELESS SET-UP

AURORA REMOTE DISPLAY

1. With factory installed Radio Modules, the external antenna must be connected to the SMA terminal on the bottom of the Electronics Carriage.

The Aurora is ready to receive radio signals.

2. If problems are experienced, ensure that the Radio Module hasn't been disconnected in shipping. The Radio Module should be secure in the terminals (J10 & J11) as seen below.

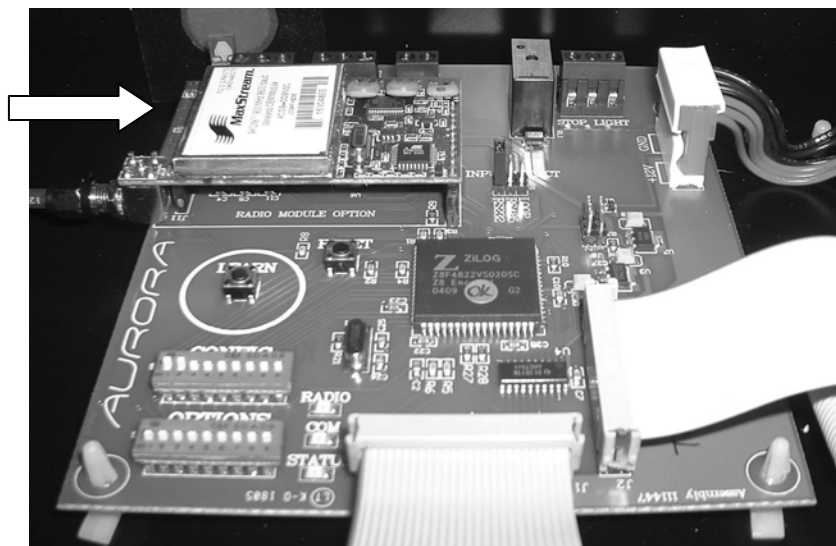

Fig. 13: Radio Module on Controller board



NOTE: When the Radio Module is properly installed, the Communication Input Jumper is over-ridden.

INDICATOR & BASESTATION

1. Connect the BaseStation to scale indicator (or other appropriate device) using the serial interface cable provided. Interface cables are Beldon Type 8723. See table for pin outs:

| INDICATOR | 9 PIN (MALE) CONNECTOR |
|---------------------|------------------------|
| TRANSMIT (TX) | PIN 3 |
| RECEIVE (RX) | PIN 2 |
| SIGNAL GROUND (GND) | PIN 5 (GND) |

2. The indicator should be set to output **CONTINUOUSLY** in the following format (RS 232):

| | |
|-----------|------|
| Baud Rate | 9600 |
| Parity | None |
| Data Bits | 8 |
| Stop Bits | 1 |



NOTE: If the indicator cannot be set as above, the BaseStation settings must be adjusted. See **BaseStation Set-up**.

3. Apply power to BaseStation using the 12 V power supply provided.

The unit should now be transmitting the indicator's output string.

Wireless Connection Test

1. Add weight to the scale.
2. Verify that the Aurora is correctly displaying Weight, Measurement Units (kg, lb), and Weighing Mode (GR, NT) as shown on the scale indicator.
3. If the Aurora's readings are incorrect, erratic, or very slow, a different radio channel may need to be selected.

BASESTATION SET-UP



NOTE: In most cases, the default settings will work well. No BaseStation set-up will be required.

To configure the BaseStation settings, a PC with the MaxStream X-CTU software (included) is required.

1. Install MaxStream X-CTU software on PC.
2. Connect the BaseStation radio modem to PC Com Port using serial interface cable (included).
3. Open MaxStream X-CTU software and select appropriate Com Port (i.e. COM 1).

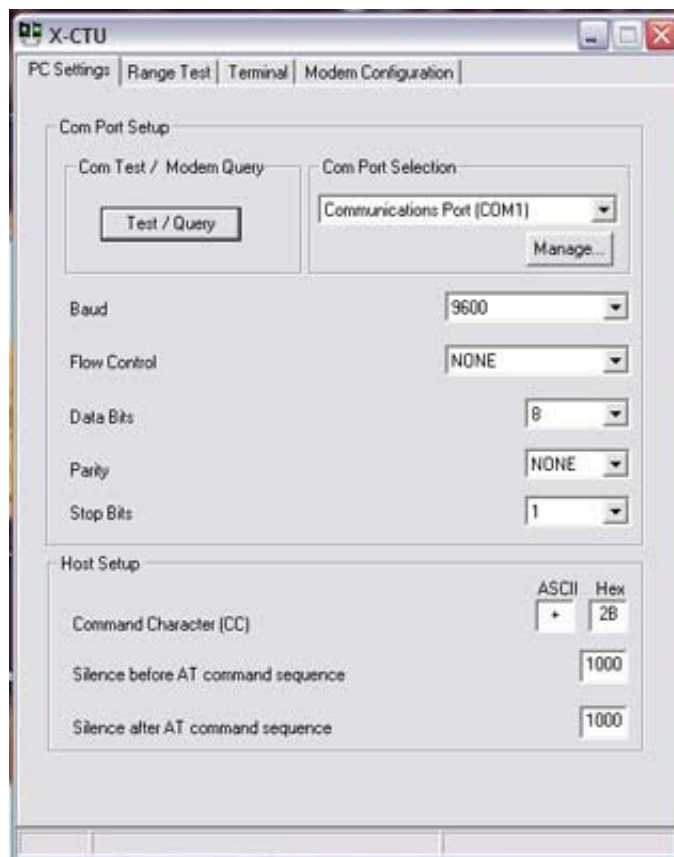

4. Click “Test/Query” button to verify communications. A window appears stating “Communication with modem...OK”.

BASESTATION SET-UP (Continued)

5. Click on the MODEM CONFIGURATION tab.
6. Select the appropriate radio (X09-009) from the MODEM pull-down menu.
7. Click the READ PARAMETERS button. The BaseStation will send its current set-up information to the PC.

Select the Radio Channel

1. Scroll down to the “Networking folder”.
2. Click on the “Hopping Channel” parameter.
3. Enter the desired channel number (0 - 6). This channel must match the channel selected using the Aurora’s dip switches.
4. Click the “Write Parameters” button. The PC will send the new set-up information to the BaseStation.

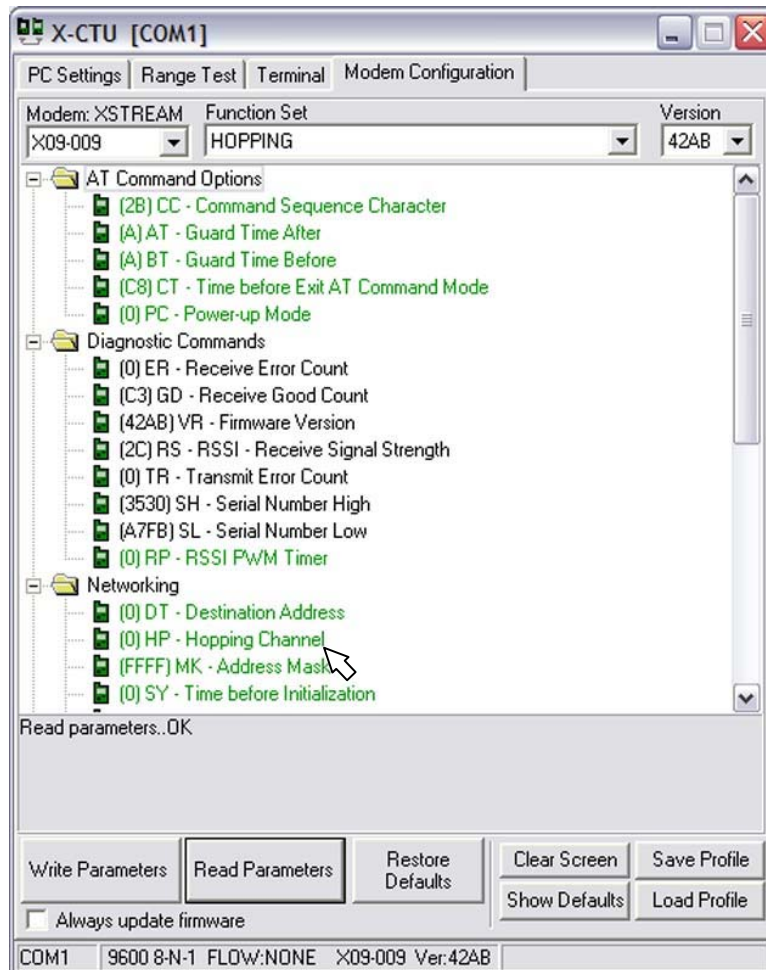

Set the Baud Rate

1. Scroll down to the “Serial Interfacing Options”.
2. Click on the “Baud Rate” parameter.
3. Select the desired Baud Rate from the pull-down menu. This Baud Rate must match the indicator’s Baud Rate.
4. Click the “Write Parameters” button. The PC will send the new set-up information to the BaseStation.

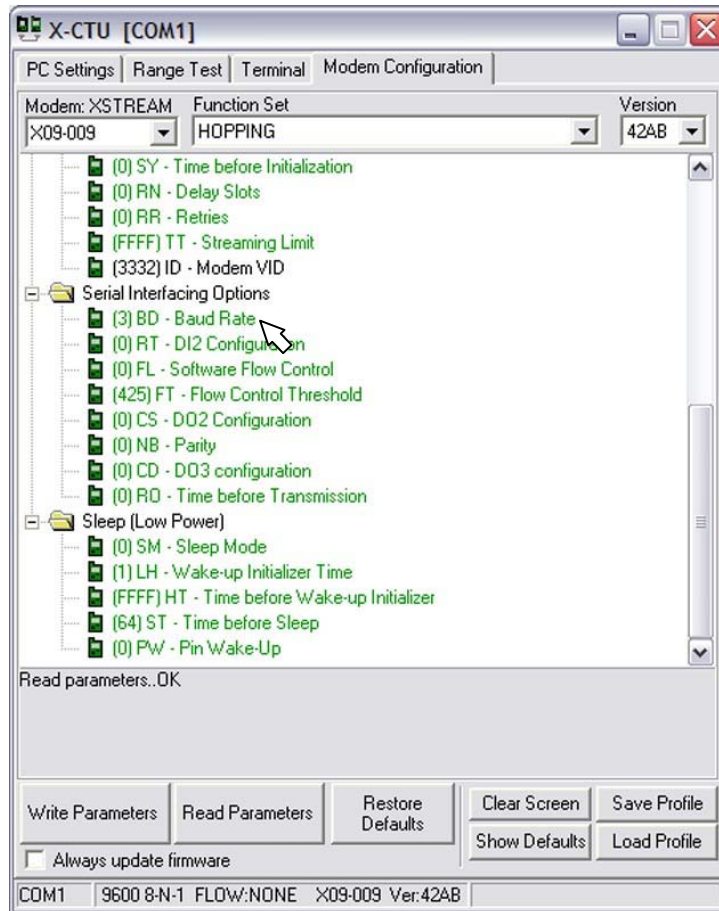

TROUBLESHOOTING & ERROR MESSAGES

| | |
|--|--|
| <p>Unit won't power up:</p> | <ul style="list-style-type: none"> • Verify AC power source (Outlets, breakers, etc.) • Check Terminal Block connections inside the Main Enclosure. • Verify power wiring from Terminal Block to the Power Supply board. • Check fuse on Power Supply board. • Verify Power wiring from Power Supply board to Controller board. |
| <p>Unit has power, but there is no display.</p> | <ul style="list-style-type: none"> • Verify Ribbon Cable connections from Controller board to the 2 Display boards. • If the unit is in COMMAND mode, the display will remain blank until data is received. |
| <p>Dashes across the display.</p> | <ul style="list-style-type: none"> • Verify the correct terminal (RS 232, 422/485, 20 mA) is being used and check wiring. • Verify that the Communications "Input Select" jumper is properly set. |
| <p>Display reads "Error 1".</p> | <ul style="list-style-type: none"> • Baud Rate Auto-Learn has failed. • Verify the correct terminal (RS 232, 422/485, 20 mA) is being used and check wiring. • Verify that the Communications "Input Select" jumper is properly set. • Verify that data is being sent to the Aurora from the indicator and that the data string contains numeric characters. |

| | |
|--|---|
| Display reads “Error 2”. | <ul style="list-style-type: none">• Data String Auto-Learn has failed.• Verify the correct terminal (RS 232, 422/485, 20 mA) is being used and check wiring.• Verify that the Communications “Input Select” jumper is properly set.• Verify that a data string is being sent to the Aurora from the indicator and that the data string contains either an STX character (ASCII 02) or a CR character (ASCII 13). |
| STATUS light NOT blinking (OFF) | <ul style="list-style-type: none">• Verify that unit has power. When powered, if the Status light remains OFF, the processor is not running. |
| STATUS light blinking fast (3/second) for longer than 30 seconds: | <ul style="list-style-type: none">• The Aurora is not able to Auto-Learn the data string or baud rate. See Auto-Learn section. |
| RADIO light not flashing: | <ul style="list-style-type: none">• Check that the Radio Module is properly installed. Ensure that the internal antenna cable is connected to the Radio Module and the external antenna.• No data is being sent from the BaseStation Radio connected to the scale indicator. |
| COM light not flashing: | <ul style="list-style-type: none">• Verify the correct terminal (RS 232, 422/485, 20 mA) is being used and check communications wiring at the indicator.• Verify that the Communications “Input Select” jumper is set to the proper communication mode (RS 232, 422/485, 20 mA).• If the Radio Module is being used, also see Probable Solutions for “Radio light not flashing”. |