

**Model: 355**

**Kit Number: 0977-0096**

**Description: Main PCB, Serial, and Ethernet Interface Kit**

### Kit Description

This kit will convert the Model 355 to allow connection to an Ethernet Network using 10-Base-T wiring in a star or tree topology and connect to a remote scale base with the Serial Interface. This kit is required before installing the Ethernet Upgrade Kit if the Model 8450 Main PCB is the older (\*)14475900A PCB. The kit contents are shown below.

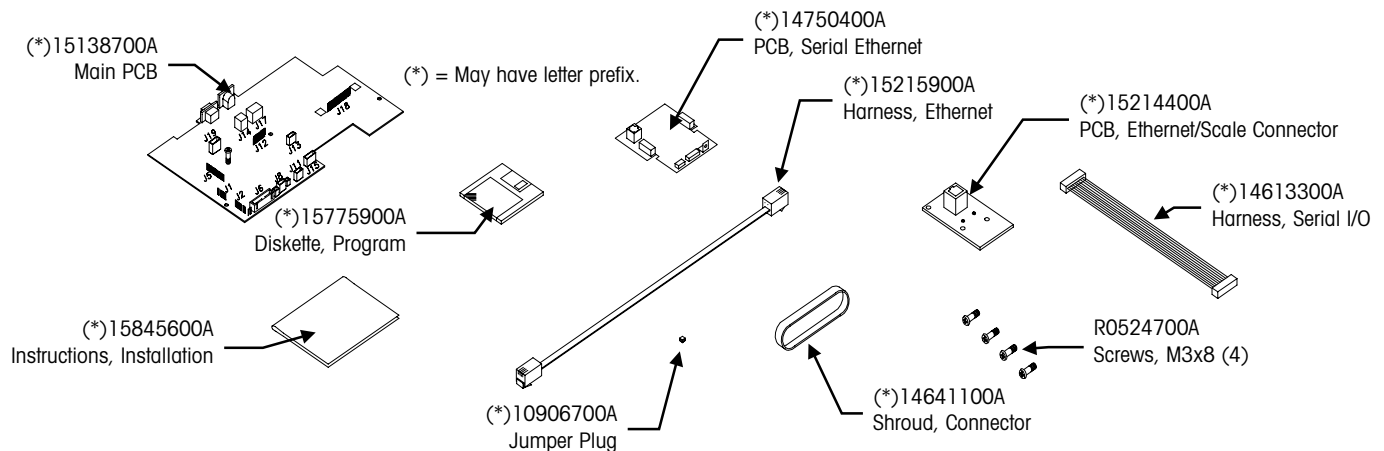

**0977-0096 Kit Contents**

### Kit Installation

Disconnect the AC power cord from the outlet before proceeding.

Remove the left printer cover. Disconnect the power supply and printer harnesses from the Main PCB. Remove the three mounting screws. Remove the Main PCB. Install the new Main PCB in reverse order.

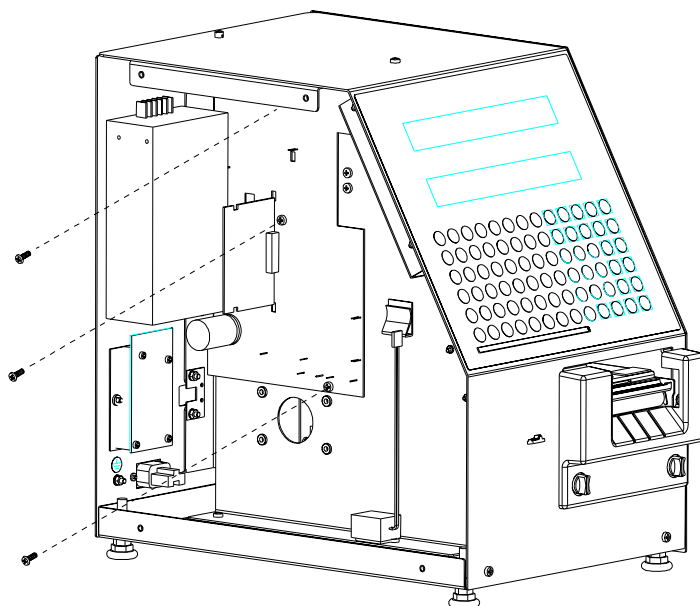

**Main PCB Replacement**

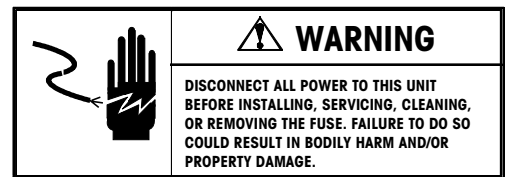

**METTLER TOLEDO**  
Scales & Systems  
1900 Polaris Parkway  
Columbus, Ohio 43240

METTLER TOLEDO® is a registered trademark of Mettler-Toledo, Inc.  
© 1999 Mettler-Toledo, Inc.  
Printed in USA

After the Main PCB is installed, install the Ethernet parts as shown below.

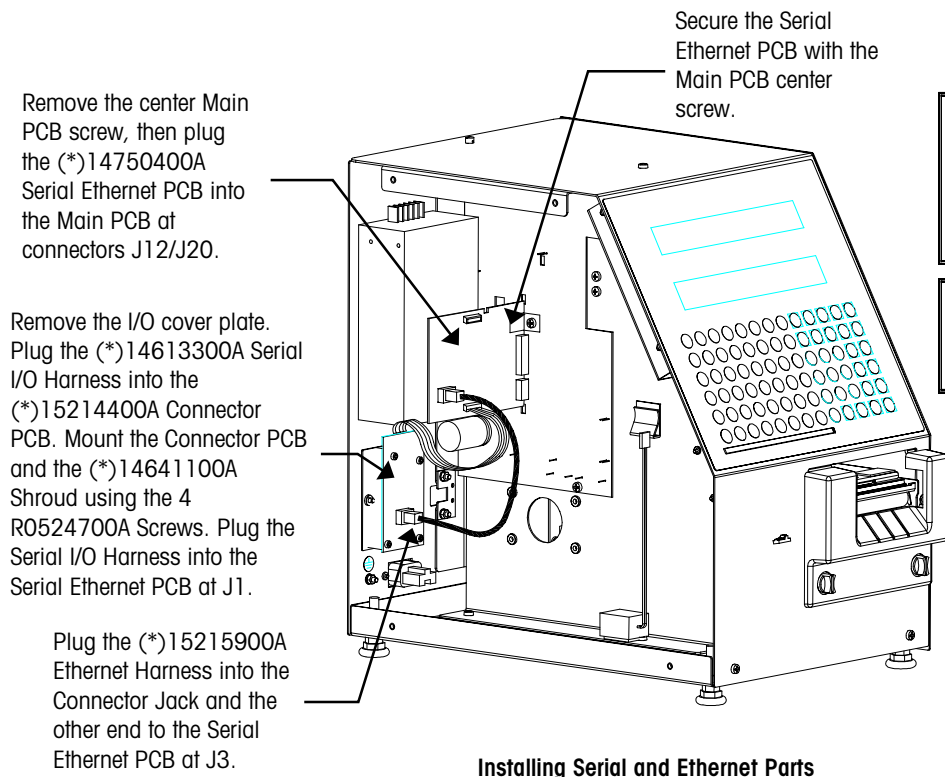

	<b>WARNING</b> DISCONNECT ALL POWER TO THIS UNIT BEFORE INSTALLING, SERVICING, CLEANING, OR REMOVING THE FUSE. FAILURE TO DO SO COULD RESULT IN BODILY HARM AND/OR PROPERTY DAMAGE.
---	--

	<b>CAUTION</b> OBSERVE PRECAUTIONS FOR HANDLING ELECTROSTATIC SENSITIVE DEVICES.
---	---

Installing Serial and Ethernet Parts

Reinstall the side cover when the kit installation is completed.

The kit is shipped with a program diskette for the Ethernet software. The new software must be flashed into the unit before it can be used on the Ethernet network. Copy the contents of the diskette to a separate sub-directory on your PC's hard disk drive. The program files are compressed and must be uncompressed before they can be downloaded to the scale. The files are self-extracting, requiring you to just type in the file name to uncompress them (example: 12345R). The new files created are the software program files (Example: 12345R.HEX) that are used with FLASHPRO (the downloader program also on the diskette) to download the program into the unit.

Before downloading the software, turn the power switch OFF. Connect the cable (see Flashpro Hardware illustration on next page) end marked PC to the PC's serial port and the other end to the Model 355 AUX Port, located on the rear of the unit. With power off, press and hold the CAL Switch, then turn the power switch to ON, then release the switch when the display indicates it is ready for download. Type in the flashpro command line and press ENTER. The FLASHPRO command line is as follows:

**FLASHPRO -tfilename.hex**

(Replace filename.xxx with the actual file name on the distribution diskette. Example: FLASHPRO -t123456R.hex) If you get a DOS Bad command or file name error, check to make sure you have not mis-typed the file name (ex: FLASHPRO), and the file FLASHPRO.EXE is in your PC's path or current directory.

The PC display should show ACKNOWLEDGEMENT. (If a UART Error is displayed, check that the cable is connected to COM1, and the correct cable is used.) FLASHPRO will display A's during the download process, (Acknowledgment). When the download is complete, FLASHPRO will display the message "File Transfer Successful".

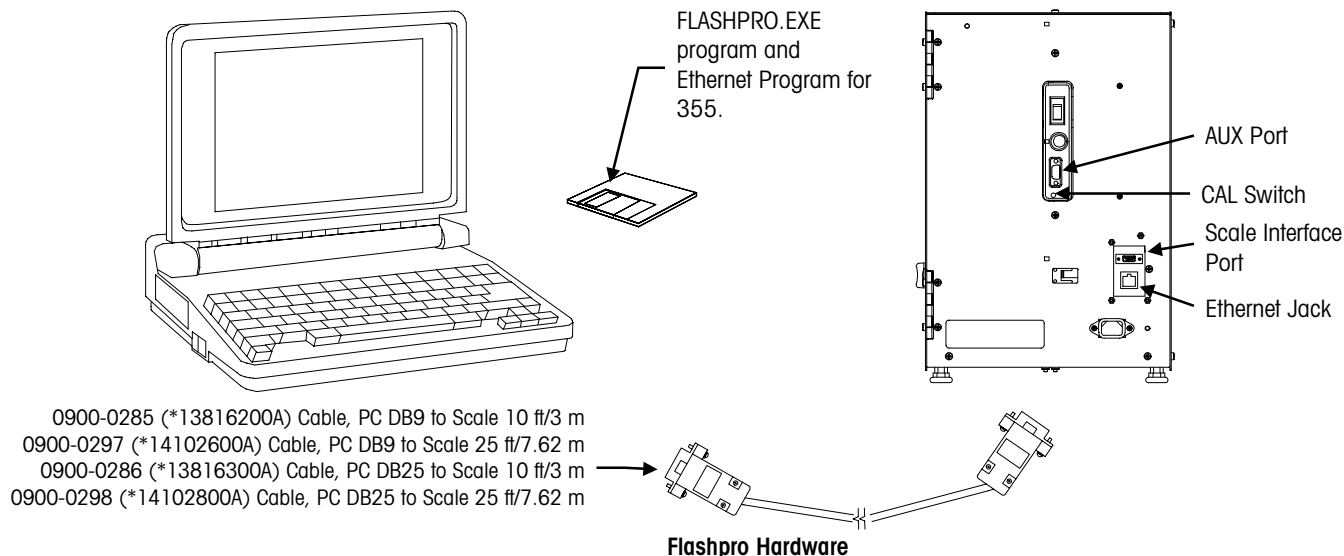

### Configure the Model 355

Refer to the Service Manual for setup details. The Ethernet configuration is accessed by the UNIT ID key in setup mode. The following must be set up for the Ethernet network. To find the Windows NT Server IP address, click START, PROGRAMS, then COMMAND PROMPT on the NT Server. Type IPCONFIG at the DOS prompt to display the IP address of the server. Write this number down. It will be used to enter into the client configuration.

At the Model 355, press the SETUP MODE key, then the UNIT ID key and enter the following items at the prompts.

**SCL?** - The IP Address identifies the client on the network. The IP Address is a unique number consisting of four parts separated by periods. (Ex: 146.207.40.1)

**GW?** – Gateway IP address is used if the server is on a different network.

Use the following key sequence to set the client IP address and Gateway address. The example shows setting the IP address to 146.208.104.015.

```

Press:    SETUP
Press:    ENTER
Press:    UNIT ID
Display:  SCL 255.255.255.255
Press:    ENTER
Display:  SCL? 255.255.255.255      (SCL is this scale's IP.)
Key In:   146 208 104 015          (no spaces or .'s needed)
Press:    ENTER
Display:  Port 0
Press:    ENTER
Display:  Port ? 0
Key In:   2305                    (always set to this number)
Press:    ENTER
Display:  GW 255.255.255.255      (GW is the Gateway's IP.)
Press:    ENTER
Display:  GW? 255.255.255.255
Key In:   146 208 104 100          (no spaces or .'s needed)
Press:    ENTER
Display:  SCL 146.208.104.015     (where xxx shows the new number entered)
Press:    CLEAR to exit setup mode.
    
```

Turn power off and back on to reset the scale with the new data.

### Cable Connections

The 10Base-T Ethernet Jack is located on the rear of the Model 355. The 10Base-T wiring uses unshielded twisted pair (UTP) cabling of Category 3 (or higher) in a *star topology*. Each node on the network has its own cable that connects to a common hub (repeater). The cable from the node to the hub can be up to 100 meters (328 feet) in length. 10 Base-T requires the use of a hub. The hub serves as a central switching station that controls the incoming and outgoing signals. When using star topology if a station goes down it does not affect the rest of the network. Typically an RJ45 connector is connected to UTP cabling and is run straight from the hub to the device on the network. Pins 1 and 3 transmit data, and pins 3 and 6 receive data (the other pins are not used).

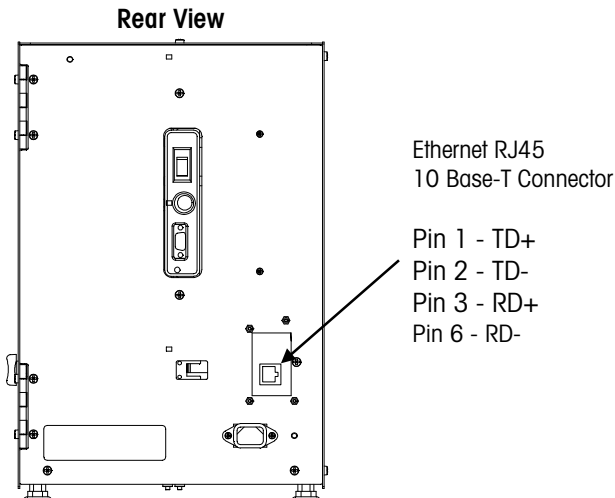

### Connecting to the Model 8270 Remote Scale Base

Disconnect power to the Model 355. Using Cable 0900-0305, connect the DB-9 connector from the Model 8270 scale base to the Scale Interface Port DB-9 connector installed on the Model 355 I/O Connector PCB. The Model 8270 scale base must be installed on a stable level surface. The stability and level is adjusted using the scale feet with the bubble indicator on the scale spider as a reference (see illustration).

Remove cover plate from Model 8270 scale base and install Jumper P/N (\*)10906700A on both pins of W4. The W1 jumper should already be installed from the factory and jumpers W2 and W3 should be open.

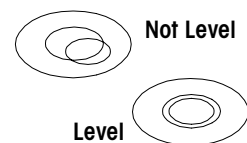

### Calibration with the Model 355

Reconnect AC power and place power switch to the ON position. Insert the Setup Mode Keyboard Overlay. (Refer to the Model 355 Service Manual for details and illustrations.) First press the SETUP MODE key. If asked for a password, press the CAL Switch.

Press the CAL key. Press UP or DOWN to display **LOAD CELL**, then press ENTER. Press UP/DOWN to display **EXT-8270**, then press ENTER to accept. Next, press the UP or DOWN keys until **CALIBRATE** displays.

When **CALIBRATE** displays, press ENTER to start the calibration procedure.

1. The display will show **Empty Scale, Enter**. Make sure the scale platter is empty, then press the ENTER key.
2. The display shows **Capturing Zero...** and the top display counts down from 15 while setting zero.
3. The scale will next ask for amount of test weight: **Load: 20.00**. Recommended minimum test weights are 20 lb or 10 kg. Place the test weight on the scale pan. Enter the amount of the test weight, then press the ENTER key (or just press ENTER if the displayed value is correct). The display will show **Capturing Span...**, and the top display will count down from 15 while setting span (full capacity).
4. When calibration is complete, the display shows **Calibrated!!!**.

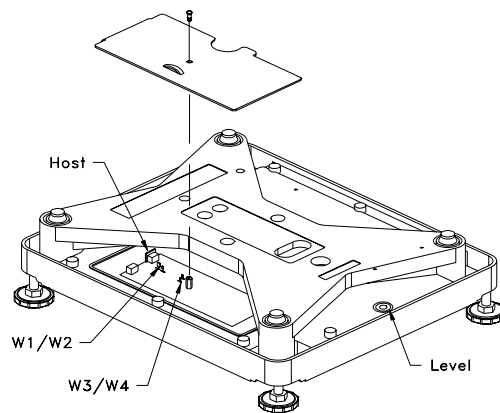

**Model 8270 Scale Base**