

## An Explanation of LCD Viewing Angle

### General

LCD displays have a limited viewing angle. They lose contrast and become hard to read at some viewing angles and they have more contrast and are easier to read at others. The size of the viewing angle is determined by several factors, primarily the type of LCD fluid and the duty cycle. Because the viewing angle tends to be smaller than most people would like, a bias is designed into the module at the time it is manufactured. This means the nominal viewing angle is offset from the perpendicular by some amount. Several versions of the LCD module are then offered with this bias set to different angles or positions to accommodate as many applications as possible. The term "bias angle" is often used erroneously with the term "viewing angle".

### Definition of bias angle and viewing angle

The bias angle is the angle from the perpendicular from which the display is best viewed. (See figure #1) This angle is determined when the display is designed, and can be set at any angle or orientation. The orientation of the bias angle of an LCD display is often stated with reference to a clock face. If the offset is above the display, it is referred to as a "12:00" or "top" view. Hantronix offers standard LCD displays with either a 12:00 or 6:00 viewing position, and can produce a custom display with any viewing position.

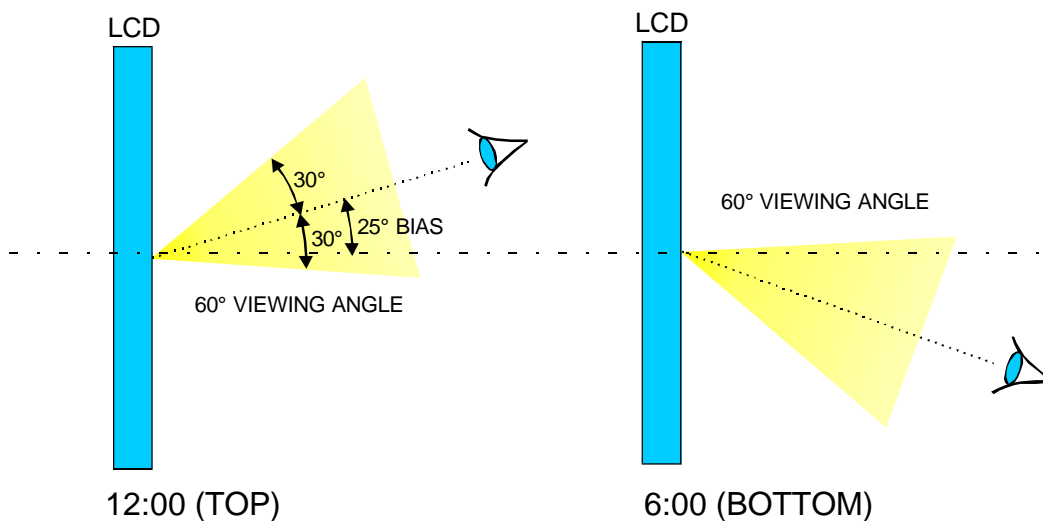

### DEFINITION OF VIEWING ANGLE (SIDE VIEWS)

Figure #1

The viewing angle is the angle formed on either side of the bias angle, where the contrast of the display is still considered acceptable. Hantronix specifies this acceptable contrast as 1.4:1. An STN character display running at a duty cycle of 1/16 has a viewing angle of  $\pm 20$  degrees, and a bias angle of 25 degrees. For this example, assume the display is a 12:00 (top viewing) type. When the display is viewed from 25 degrees above the vertical, it will have its maximum contrast and best "look". If the viewer moves his eye further above the display by an additional 30 degrees, he will see the display reduce in contrast (but still be easily readable). Moving the viewing position any further above the display will reduce its contrast to an unacceptable degree.

### Contrast adjustment and its effect on viewing angle

Adjusting the contrast voltage,  $V_L$ , will effect the bias angle to some extent, but not the viewing angle. A 12:00 display can be optimized for a 6:00 viewing position by adjusting the contrast voltage. A 12:00 display set for 6:00 viewing position will not have as great a contrast as a 6:00 display set for 6:00 viewing position, and vice versa.

Designers often want a display to be optimized for straight-on viewing. Either a 12:00 or a 6:00 module can be used; and the contrast voltage can be adjusted slightly to optimize the display for that viewing position. In the example used above, the viewing angles of both the 6:00 and 12:00 modules actually overlap the perpendicular (or straight on) viewing position.

### Contrast adjusting procedure

Once the viewing position has been established for a design, the contrast setting can be determined. This is normally done during product development on the prototype unit. A potentiometer of about 10k ohms is connected between  $V_{DD}$  and  $V_{SS}$  in a single supply module, or from  $V_{DD}$  to the negative rail in a dual supply module. The wiper of the pot is connected to the  $V_L$  input of the module. (See figure #2) The LCD is positioned at the nominal viewing position, and the pot is adjusted to obtain the desired LCD appearance. The voltage on the  $V_L$  pin is now measured, and a pair of resistors are chosen to produce this voltage in the production units.

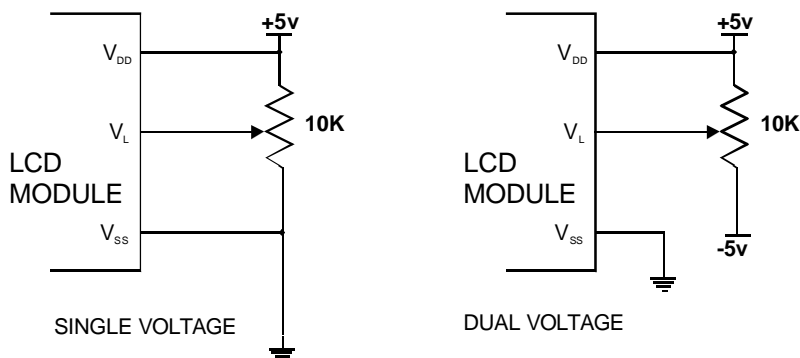

Figure #2

### Choosing the right module for your application

Most electronic devices have a preferred viewing position. For a device that sits on a desk, such as a calculator, the display is generally viewed from below. This is usually true for a small hand held instrument, also. In these applications a 6:00 module would be preferable. For an LCD display mounted in the dashboard of a vehicle or aircraft, a 12:00 module is a better choice.

### Conclusion

Selecting an LCD display with the proper viewing angle is important, but the designer must keep in mind that the contrast setting is also important as both of these parameters work together to determine the appearance of the LCD and the final appearance and appeal of your product.