

TECHNICAL MANUAL

WEIGHT INDICATOR



SOFTWARE FOR WHEEL / AXLE WEIGHING



WHEELS WEIGHING

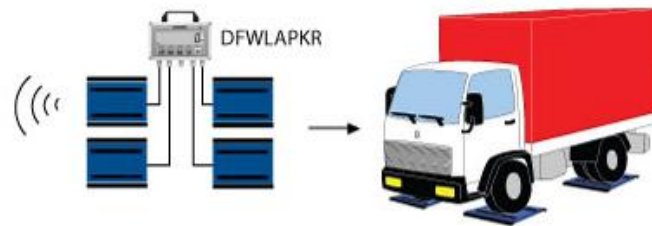

AXLES WEIGHING



INDEX

1. REQUIREMENTS FOR AN EFFECTIVE INSTALLATION	3
2. CONNECTIONS TO TRANSDUCER	4
2.1 DFWKRP, DFWKRPRF	4
2.2 DFWLAPKR.....	4
3. SETUP ENVIRONMENT	5
3.1 SET-UP ENVIRONMENT BLOCK DIAGRAM.....	7
3.2 DESCRIPTION OF THE STEPS.....	9
4. CALIBRATION.....	19
4.1 CALIBRATION OF WIRELESS PLATFORMS (WWSERF) CONNECTED TO DFWKRPRF	20
4.1.1 CALIBRATION EXECUTED ON THE INDICATOR OF THE WWSERF	20
4.1.2 CALIBRATION EXECUTED ON THE DFWKRPRF	21
4.2 IN CASE THE ZONE OF USE IS DIFFERENT FROM THE CALIBRATION ZONE ONE SHOULD:	21
4.3 QUICK CALIBRATION OF ZERO	22
4.4 QUICK CALIBRATION OF A DEFINITE WEIGHT	22
4.5 MANUAL CALIBRATION OF A DEFINITE WEIGHT	22
5. DISPLAY OF THE GRAVITY ACCELERATION AND CORRECTION OF THE WEIGHING ERROR due to the different gravity acceleration between calibration zone and utilisation zone	23
6. SERIAL OUTPUTS	24
6.1 PC SERIAL PORT	24
6.2 PRN SERIAL PORT.....	25
6.3 CONNECTION OF THE RADIO MODULE ON DFWLAPKR	25
6.4 SERIAL PORT TRANSMISSION MODES	26
6.4.1 PC PORT	26
6.4.2 PRN PORT	27
6.5 FORMAT OF THE SERIAL COMMANDS.....	28
6.6 TRANSMISSION PROTOCOLS	34
7. PROGRAMMING THE PRINTOUTS.....	36
7.1 FORMATTING DATA AND LAYOUT	39
8. PRINTING THE HEADING.....	43
9. ANALOGUE OUTPUT (OPTIONAL)	46
10. ENERGY SAVING.....	48
11. CONFIGURATION OF DFWKRPRF CONNECTED TO WWSERF PLATFORMS	48
12. CONFIGURATION OF DFWKRPRF AS REPEATER.....	48
13. CONFIGURATION OF THE SYSTEM DFWKRPRF- DFWLAPKR.....	49
14. CONNECTION SCHEMES.....	50
14.1 DFWKRP, DFWKRPRF MOTHERBOARD	50
14.1.1 I/O OPTIONAL EXPANSION CARD WITH 2 INPUTS AND 2 OUTPUTS.....	52
14.1.2 RS 485 OPTIONAL SERIAL	53
14.2 DFWLAPKR.....	54
14.3 LOAD CELL CONNECTOR CIRCUIT DIAGRAM	56

NOTE FOR THE TECHNICIAN:

Please take note that when the “StEP.... (USER MAN.REF.)” is mentioned, this refers to the user manual.

**1. REQUIREMENTS FOR AN EFFECTIVE INSTALLATION**

To obtain the best results it is recommended to install the indicator and the platform (or transducer) in a place with the following conditions:

A flat, level surface on which to rest

Stable and vibration free

Moderate temperature and humidity (15-30°C and 40-70%).

No dust or strong vapours

No draughts

Mains power supply is restricted to within $\pm 10\%$ of the rated voltage

Make sure the platform is level or that the loading cells are resting evenly

Avoid welding with load cells installed.

When the load cells are used with assembling kits under storage bins or the like, connect the upper and lower supporting plate with a copper wire cable and then earth all the upper plates.

Use waterproof sheaths and couplings in order to protect the load cell cables.

Use a waterproof junction box to connect the cells.

The extension leads of the load cells or signal amplifiers must be screened. In addition they must be laid in their own in conduit or metal pipe as far away as possible from the power supply cables.

Connection of the cell or amplifier cables on the electrical panel shall be independent and, if possible, connected directly to the KD/3590's terminal board without laying other cables in the conduit.

Install “RC” filters on the contactor coils, on the solenoid valves and on all devices producing electric disturbances.

If it is possible that condensation could form inside the weight transmitter it is advisable to leave the instrument powered at all times.

Electric protection (fuses etc.) are provided by the technician installing the instrument.

Do not install anywhere where there is the risk of explosion.

Make sure that the indicator and load cell shields are grounded well.

All the connections of the indicator have to be made respecting the rules applicable in the zone and in the installing environment.

Everything not expressly described in this manual has to be considered as improper use of the equipment.

2. CONNECTIONS TO TRANSDUCER

2.1 DFWKRP, DFWKRPRF

After having followed the instructions regarding the platform or the load receiver, the screened cable leading from the load cell(s) must be connected to the instrument through the CELL1 terminal board and the CELL1 (see the section "CONNECTION SCHEMES") through the relative input (section "INSTALLATION", **USER MAN.REF.**).

The CELL1 terminal board of the indicator may be connected to the 6-wire load receiver (with use of SENSE), or simply 4-wire; for this, through jumper J10 and J11 it is possible to choose whether to short-circuit the SENSE with the POWER SUPPLY (jumpers closed) or not (jumpers open).

The sense allows compensating for any drops in voltage in the part of the cable that connects the instrument to the transducer. It is useful when the distance between the indicator and the transducer is greater than 10 m.

The 4-pin connectors instead allow just the 4-wire connection.

To make the connection qualified personnel must open the instrument (see the paragraph "CONNECTION SCHEMES").

Technical Note: on the external power cable, on the battery cable (near the terminal on the CPU card), and on the connection cable to the load receiving device (near the cable entrance of the instrument) some ferrite rings are installed or, at times, supplied together with the instrument to reduce possible radio frequency disturbances.

All cables must be wound at least once around the ferrite ring before being connected to the terminal board; the cable screen must be left outside of the ferrite and should be connected to the relevant ground pin.

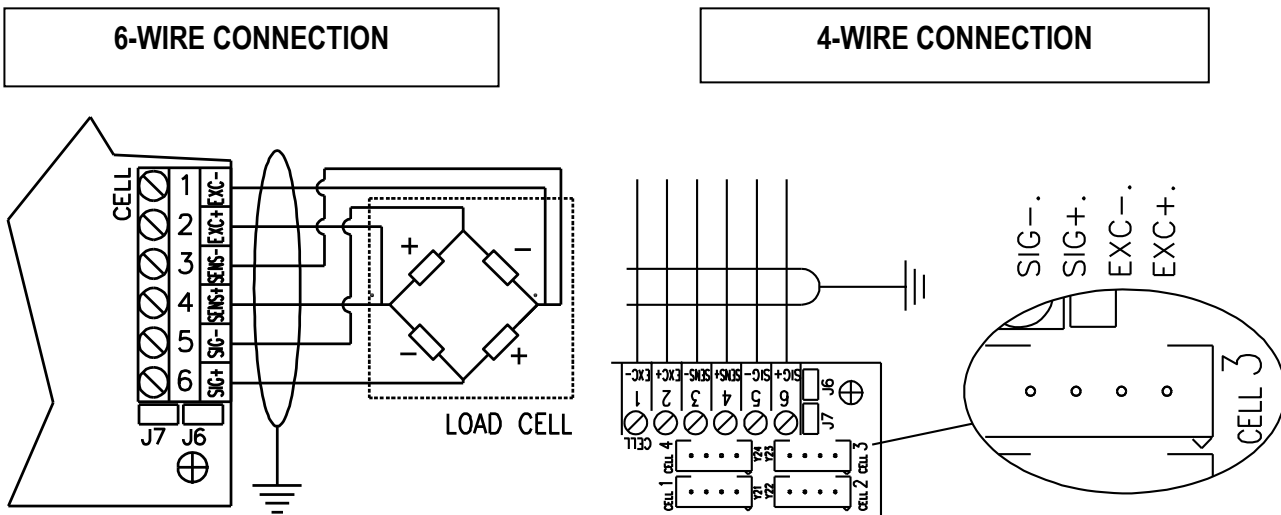

2.2 DFWLAPKR

After having followed the instructions regarding the platform or the load receiver, the screened cable leading from the load cell(s) must be connected to the instrument through the CELL1 connector or the CELL1, 2, 3, 4 connector (see the section "CONNECTION SCHEMES") through the relative input (section "INSTALLATION", **USER MAN. REF.**).

The CELL1 and SENSE connectors of the indicator may be connected to the 6-wire load receivers (with use of SENSE), or simply 4-wire, to the CHANNEL 1; for this, through jumper J2 and J3 it is possible to choose whether to short-circuit the SENSE with the POWER SUPPLY (jumpers closed) or not (jumpers open).

The sense allows compensating for any drops in voltage in the part of the cable that connects the instrument to the transducer. It is useful when the distance between the indicator and the transducer is greater than 10 m.

The CELL1, 2, 3, 4 connector allow the 4-wire load receivers connection (without use of SENSE), to more CHANNELS.

To make the connection qualified personnel must open the instrument (see the paragraph "CONNECTION SCHEMES").

6-WIRE CONNECTION

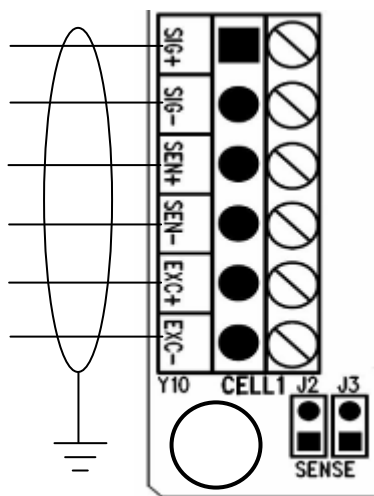

J2 OPEN
J3 OPEN

4-WIRE CONNECTION

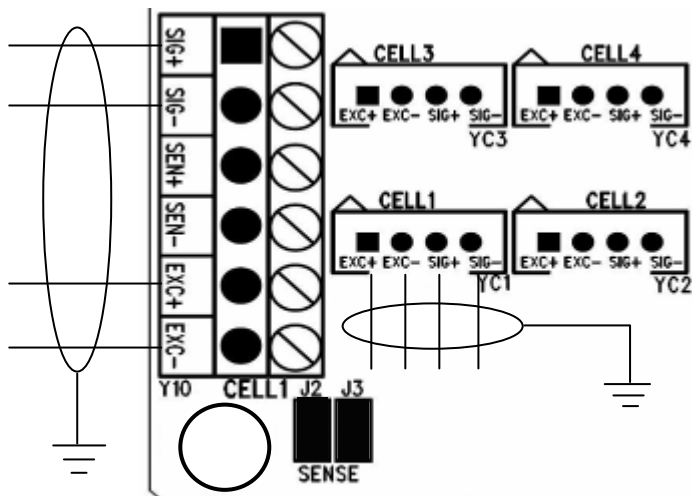

J2 CLOSE
J3 CLOSE

TECHNICAL PERSONNEL ONLY

3. SETUP ENVIRONMENT

With "SETUP ENVIRONMENT" we intend a specific menu, inside which it's possible to set all the functioning parameters of the indicator.

To enter it, turn on the instrument and, while the firmware version is being displayed, press the TARE key for an instant.

The indicator shows:

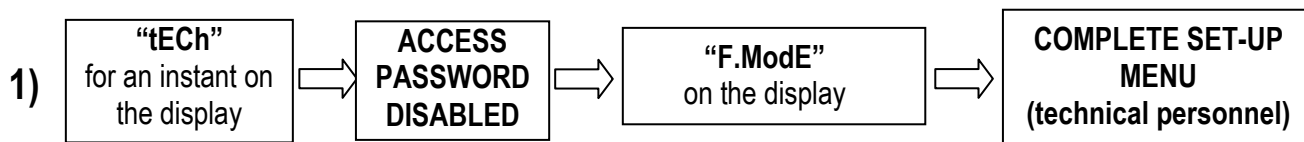

or

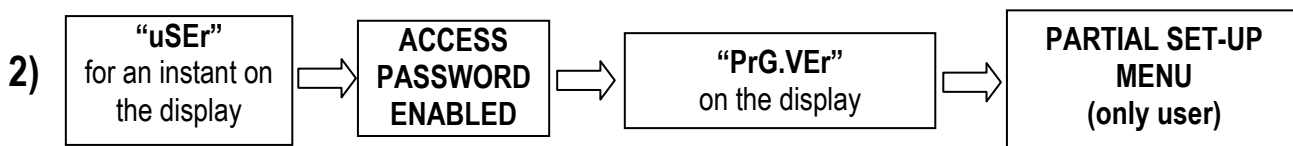

If you are in choice 2) and you want to access the complete set-up menu one should:

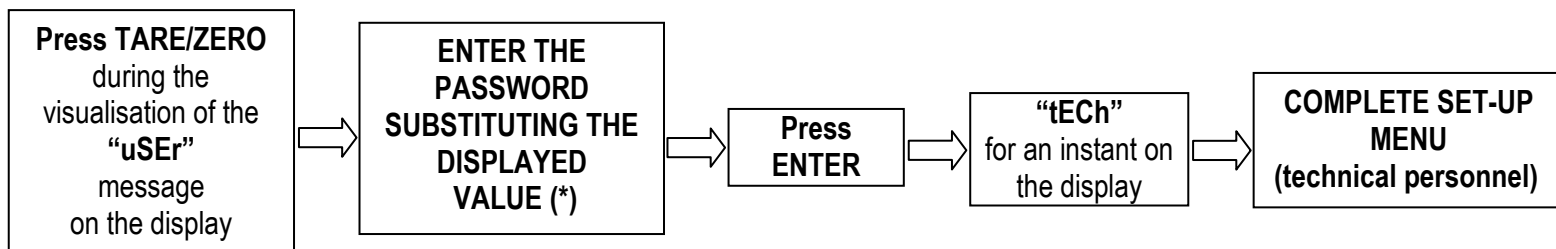

(*) If one has forgotten the password, one should communicate the displayed number to the manufacturer, who will supply a valid password JUST FOR THAT SPECIFIC NUMBER.

In the Set-Up condition, the instrument keys allow the user to perform the following functions:

ZERO	Scrolls the programming steps forward in sequence.
TARE	Allows scrolling backwards through the programming steps.
MODE	Allows to quickly position on the first step of a menu.
ENTER/PRINT	Allows to enter a step or confirm a parameter inside a step.
C	Allows to exit a step without confirming the possibly modified parameter and go to the preceding level. When entering a numeric value it quickly zeros the displayed value.
NUMERIC KEYS	One can enter numeric values, from right to left.

In the parameter description and in the block diagram:

- The **METRIC** parameters are shown with the (*) symbol, and, with approved instrument, these may not be visible or read only. See the explanation of the parameter for the details.
NOTE: The indicator is approved when the J1 jumper (CAL) of the motherboard is open (see the electrical scheme in the final chapter).
- The **CONDITIONAL STEPS** are shown with the (§) symbol, and are not displayed in specific conditions, shown in the step description.
- The **DEFAULT VALUES** are shown with the (!) symbol placed next to the step and at the end of it.

TO EXIT THE SET-UP ENVIRONMENT, PRESS THE C KEY MANY TIMES UNTIL THE INDICATOR SHOWS "SAVE? IN THE DISPLAY: CONFIRM WITH ENTER/PRINT TO SAVE ANY CHANGES MADE OR PRESS ANOTHER KEY TO NOT SAVE.

3.1 SET-UP ENVIRONMENT BLOCK DIAGRAM

The following diagram shows the structure of the indicator's set-up environment; each step has been described in detail in the paragraph "DESCRIPTION OF THE STEPS".

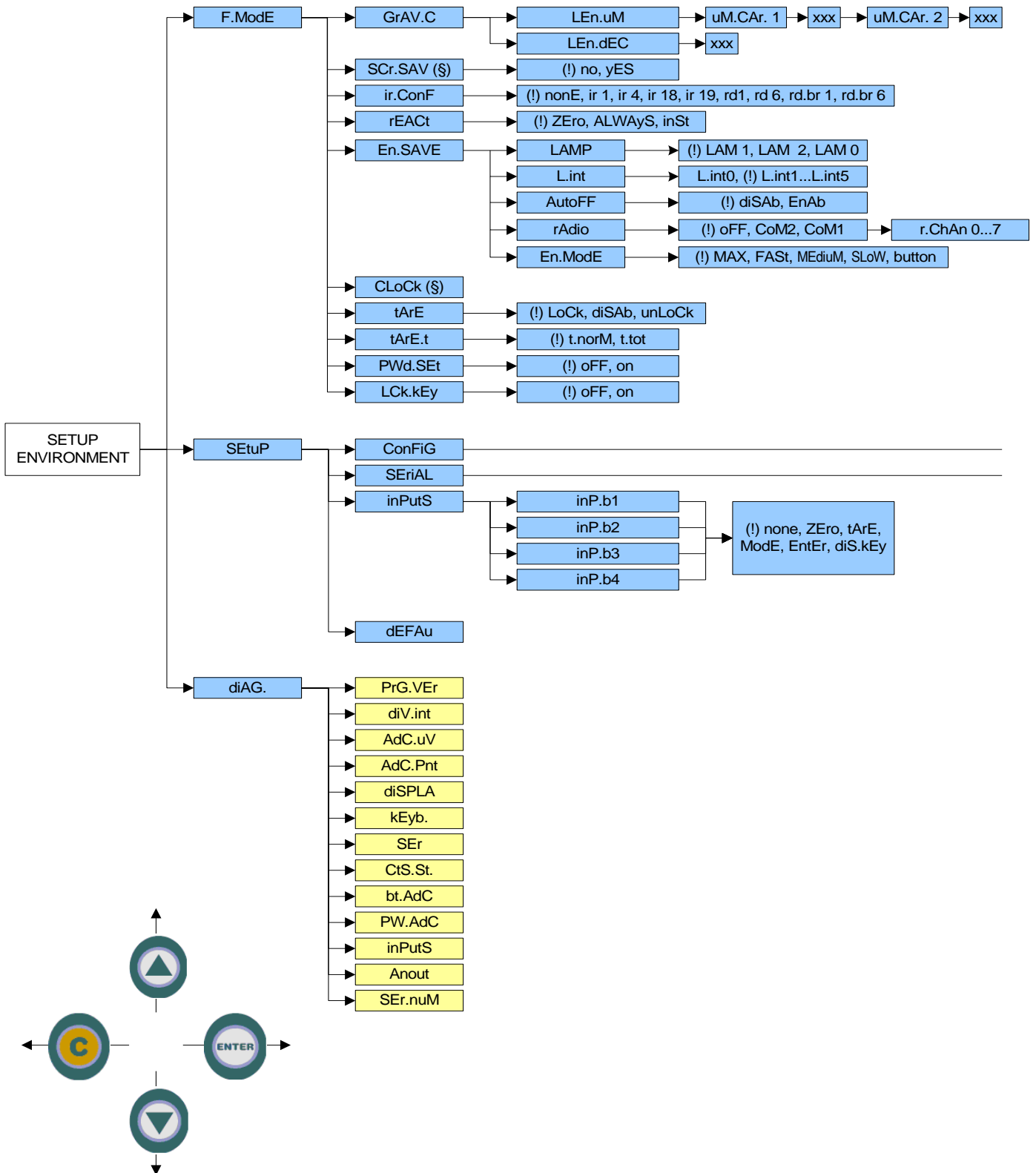

LEGEND

- = USER & TECH MENU'
- = ONLY TECH MENU'
- (*) = METROLOGICAL PARAMETER
- (§) = CONDITIONED STEP
- (!) = DEFAULT VALUE

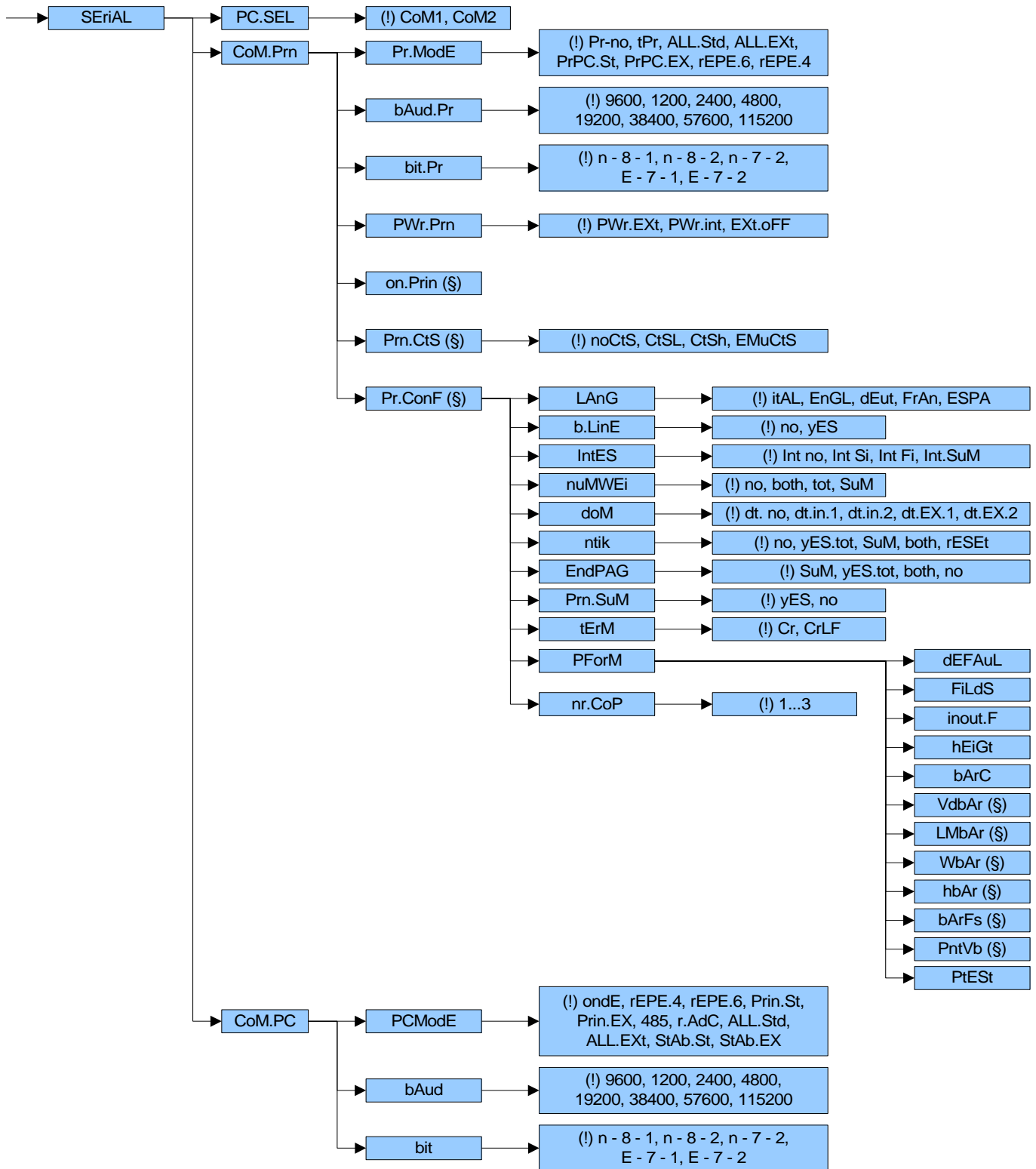

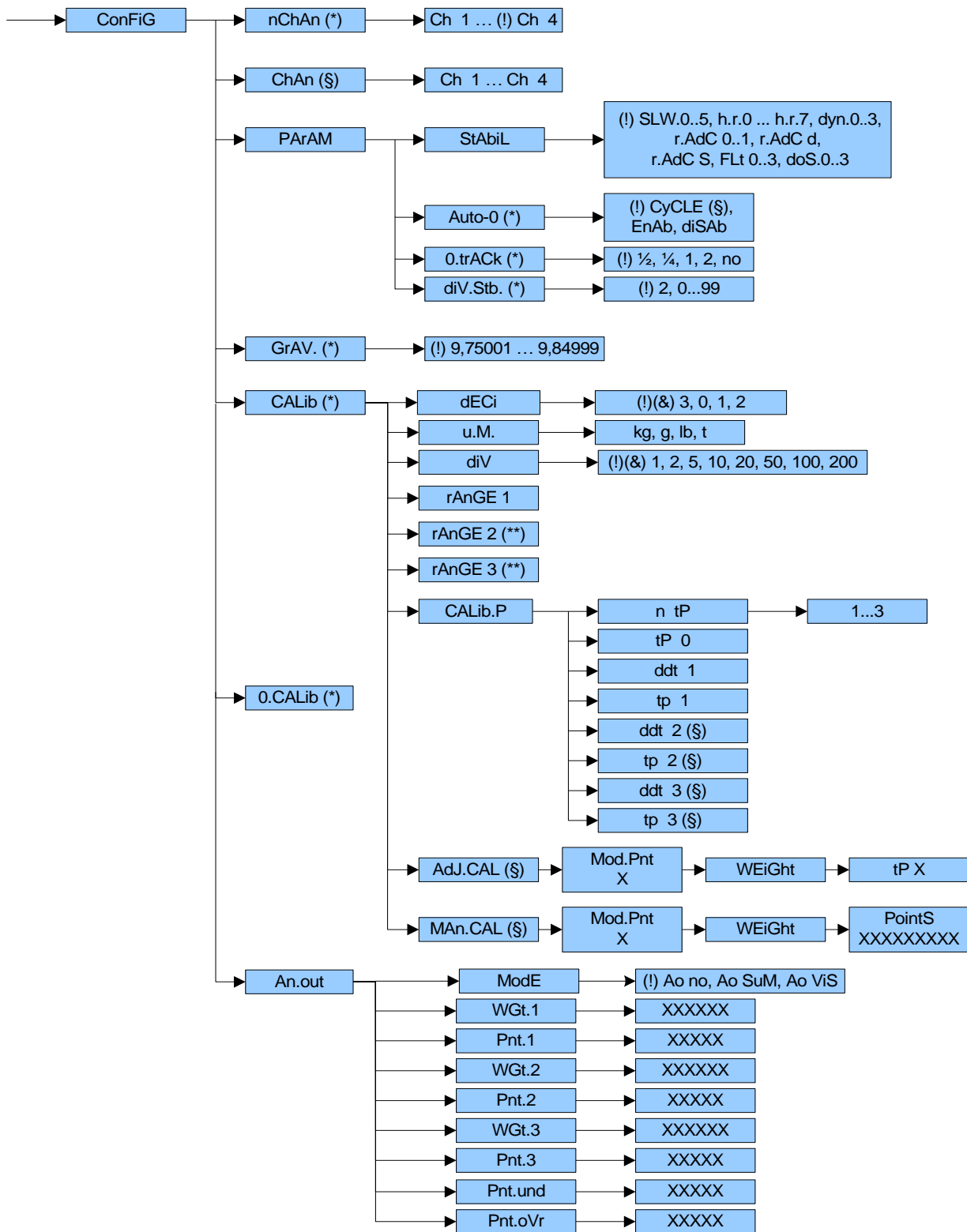

3.2 DESCRIPTION OF THE STEPS

F.ModE: INSTRUMENT FUNCTIONS

GrAV.C BARYCENTRE COORDINATES PRINTOUT CONFIGURATION

This step is for setting the unit of measure and the number of decimals with which the instruments barycentre coordinates will be printed:

LEn.uM:

setting the unit of measure with which the barycentre coordinates are printed; automatically one is asked to enter two characters:

uM.CAr.1: entry of the first character to be printed (ASCII decimal) on three digits.

(!) 032

uM.CAr.2: entry of the second character to be printed (ASCII decimal) on three digits.

(!) 109

The enterable characters go from 32 to 122 inclusive.

For example, to print the coordinates in metres, one should enter 032 in **uM.CAr.1**, while 109 in **uM.CAr.2**.

LEn.dEC:

setting the number of decimals of the coordinates; by pressing the ZERO key repeatedly, all the possible configurations will be displayed; press ENTER to select the desired one, C to exit without making modifications.

(!) 2

SCr.SAV ENABLING SCREEN SAVER (\$)

In this step one enables the screen saver, which allows viewing the time on the display; this visualisation is enabled with the scale unloaded and when it is not used for the time period which is set in this step.

The disabling of the screen saver is automatic happens in the moment in which a key is pressed or the weight becomes unstable.

yES enabling screen saver; one is asked to enter the time which the indicator waits to activate the screen saver, after the weight has become stable and keys are not pressed.

no disabling the screen saver.

(!) no

(\$) The parameter is not displayed if there is no date/time option.

ir.ConF REMOTE CONTROL CONFIGURATION

Through this step it is possible to programme the functioning mode of the remote control (optional):

none no function selected

ir 1 4-keys infrared remote control; all the keys of the remote control work as TARE key.

ir 4 4-keys infrared remote control; the remote control keys work as ZERO, TARE, F, ENTER/PRINT.

ir 18 18-keys infrared remote control; the remote control keys work as extended keyboard.

ir 19 19-keys infrared remote control; the remote control keys work as extended keyboard.

rd 1 6-keys radio remote control; all the keys of the remote control work as TARE key.

rd 6 6-keys radio remote control; the remote control keys work as ZERO, TARE, MODE, ENTER/PRINT, C and Fn.

rd.br 1 6-keys radio remote control; all the keys of the remote control keys work as TARE key.

rd.br 6 6-keys radio remote control; the remote control keys work as ZERO, TARE, MODE, ENTER/PRINT, C and Fn.

NOTES: In the "rd 1" and "rd 6" configurations it's possible to combine 3 remote controls.

In the "rd.br 1" and "rd.br 6" configurations all the radio remote controls we provide work with the instrument.

For further information refer to the instrument's user manual.

(!) none

rEACT REENABLING OF THE PRINTOUTS AND THE INDICATOR FUNCTIONS

While using the indicator, it is possible to incur in the "no.0.unS" error shown on the display accompanied by an acoustic signal; this means that the printout or the function which one wants to carry out must be reenabled (in order to avoid accidental executions).

It is possible to set the reenabling in the following modes:

ZERo passage by zero of the GROSS weight.

inSt instability.

ALWAYs always.

(!) ZERo

En.SAVE ENERGY SAVING**LAMP DISPLAY BACKLIGHTING**

Through this StEP one programmes the backlight functioning.

LAM 0 the background light is always off.

LAM 1 the backlight turns on when the weight changes or when a key is pressed; and it turns off automatically after 10 sec. that stability has been reached, or upon the pressing of the key.

LAM 2 the background light is always on.

(!) LAM 1

L.int SETTING INTENSITY OF DISPLAY BACKLIGHTING

In this step one selects the intensity of the backlighting or of the LED display:

L.int1 (minimum), L.int2, L.int3, L.int4, L.int5 (maximum).

(!) L.int 1

AutoFF ENABLING AUTO SWITCH-OFF

It is possible to enable the automatic switch off of the indicator (from 1 to 255 minutes), or disable it; the auto switch-off starts working when, **with unloaded scale**, the weight has not been moved or a key has been pressed during the set time: the display shows the blinking “- oFF – “ message and an acoustic signal is emitted; then the indicator turns off.

diSAb autoswitch-off not inserted

EnAb the indicator shows "M XXX" in which XXX is the last programmed time in minutes; enter/modify the value and press ENTER.

(!) diSAb

rAdio RADIO POWER SAVING

oFF power saving disabled

CoM2 power saving enabled in the CoM2 serial port

CoM1 power saving enabled in the CoM1 serial port

Once CoM1 or CoM2 is selected, “r.ChAn” is displayed for an instant and one is asked to enter the radio channel used (between 0 and 7).

The message “ok” is displayed if the radio module has been correctly configured, if not “Error” is displayed.

(!) oFF

En.ModE ENERGY SAVING MODE

This step allows to change the weight updating and the on/off feeding of the load cells:

MAX weight update always enabled

FASt weight update every 2 seconds

MEdiuM weight update every 5 seconds

SLoW weight update every 10 seconds

button the instrument is normally in standby (the display is off except the point): by pressing any key “ON” is displayed and the weight update is enabled for 30 second.

(!) MAX

CLoCk CONFIGURATION OF INDICATOR TIME AND DATE (§)

In this step one sets the date and time of the indicator; by pressing ENTER one is asked to enter in this order, DAY, MONTH, YEAR, HOUR and MINUTE.

The entry of each parameter must be confirmed with ENTER.

(§) The parameter is not displayed if there is no date/time option.

tArE TARE LOCKED/UNLOCKED/DISABLED

In this step one programmes the functioning mode of the TARE function; see the section “TARE OPERATIONS” (USER MAN.REF.):

diSAb tare DISABLED
LoCk tare LOCKED
unLoCk tare UNLOCKED
 (!) **LoCk**

tArE.t SELECTION OF THE TYPE OF TARE

t.norM simple mode of tare acquisition or introduction
t.tot setting of the tare totalizer

For further information refer to the instrument’s user manual (USER MAN.REF.).

(!) **t.norM**

PWd.SET SET ACCESS PASSWORD

One selects whether to enable or disable the access password to the technical menu:

on password enabled
oFF password disabled

By selecting **on**, one can insert a password of up to 5 digits. When finished entering, press **ENTER** to confirm.

NOTE: The maximum enterable value is **65534**.

(!) **oFF**

LCK.kEy KEYBOARD UNLOCKED/LOCKED

One selects whether to enable or disable the keyboard locking in the weighing phase;

oFF keyboard lock disabled
on keyboard lock enabled

For further information see the section “LOCK / UNLOCK KEYBOARD” (USER MAN.REF.).

(!) **oFF**

SEtuP: INSTRUMENT CONFIGURATION**ConFiG: CONFIGURATION OF THE METRIC PARAMETERS****(*) nChAn SELECTION OF CHANNEL NUMBER**

In this step one selects the number of channels which one wants to use (from “Ch 1” = 1 channel to “Ch 4” = 4 channels).

If the “r.AdC” parameter has been set in the **SEtuP >> SEriAL >> CoM.PC >> PCModE** step, after having confirmed the number of channels, one is asked to receive the calibration data of the connected platforms (the “r.CFG?” message is displayed: confirm with ENTER or exit with any other key).

(*) With an approved instrument the parameter is read only.

Note: With an approved instrument it’s possible to change the number of connected scales while in the weighing mode by pressing twice the **MODE** key. The maximum number of configurable channels corresponds to the last value confirmed in the **nChAn** parameter (see the section “QUICK SETTING OF INSTRUMENT’S NUMBER OF SCALES”, USER MAN.REF.).

(!) **Ch 4**

ChAn SELECTION OF THE CHANNEL TO BE CALIBRATED (§)

In this step one selects the channel which one wants to calibrate.

NOTE:

- The parameters which follow refer to the channel set in this step.
- The values of the parameters which follow when these are confirmed in the first channel, are configured also for the other channels selected in the **nChAn** step.

(§) The parameter is not displayed with an application of a single channel, **SEtuP >> ConFiG >> nChAn** step.

NOTE: To modify the number of scales being used, either with approved or non approved instrument, refer to the user manual of the instrument (**USER MAN.REF.**).

PArAM METRIC PARAMETERS (§)

(§) The value of the parameters within this step, when these are confirmed in the first channel, are configured also for the other channels selected in the **nChAn** step.

StAbiL DISPLAY MODE AND FILTERING

The possible configurable values are:

- FLt 0 – 3** filter for simple weighing
- h.r.0 – 1** filter for high resolution
- dyn.0 – 1** filter for a moving weight (e.g. animal weighing)
- doS.0 – 3** filter for dosage
- SLW.0 – 3** filter for a rather unstable weight
- h.r.2 – 7** filter for high resolution
- dyn.2 – 3** filter for a moving weight (e.g. animal weighing)
- r.AdC 0 – 1** filter for digital cells with fixed request interval
- r.AdC d – S** filter for digital cells with dynamic (d = fast, S = slow) request interval

The higher the filter value, and greater is its intervention relative to the type of filter used.

(!) SLW.0

(*) With an approved instrument it is possible to select just the **FLt 0...3**, **h.r.0**, **h.r.1**, **dyn.0**, **dyn.1** parameters.

Note: The correct filter setting for a **DFWKR – WWS** radio connection, if there aren't any sort of energy consumption issues, is **r.AdC 1** (for all the channels); otherwise **r.AdC d** or **r.AdC S** for saving energy.

(*) Auto – 0 AUTOZERO AT THE START UP

Automatic acquisition of the gross zero at start-up (up to +/- 10% of the capacity):

- EnAb** Enabled on scale 1
- diSAb** Disabled
- CyCLE** Executed cyclically on all the scales present. (§) This value is not visible if there is only one scale (see **nChAn** parameter).

If the weight on the plate is greater than 10% of the capacity, it is not zeroed and, in if the instrument is not approved, after 5 seconds the weight is displayed; otherwise with approved instrument the "ZEro" message remains shown on the display until the excess weight is not removed.

By choosing **CyCLE**, the auto zero function is active on all the connected scales.

(!) CyCLE

(*) In case of approved instrument the parameter is read only.

(*) 0.trACk DIV./ SEC. ZERO TRACKING

This menu allows to configure the zero tracking, in other words, the thermal drift compensation parameter of the scale; the set value corresponds to the number of divisions which is cleared in the fixed time of 1 second:

- **tr. ½** +/- half a division.
- **tr. ¼** +/- one fourth of a division.
- **tr. 1** +/- one division.
- **tr. 2** +/- two divisions.
- **tr. no** tracking disabled.

(!) tr. ½

(*) With approved instrument it is possible to select just the **tr. no**, **tr. ½**, **tr. ¼** parameters.

(*) diV.Stb DIVISIONS BY STABILITY

In this step one enters the number of divisions by which the instrument detects the weight stability; the higher the number of divisions, less is the sensitivity, and consequently the stability is more easily detected.

The possible values are 0 (weight always stable)...99.

(!) 2

(*) With approved instrument the parameter is read-only.

(*) GrAV. GRAVITY ZONE AND ZONE OF USE

Through this step one selects the gravitational acceleration value **of calibration and of use** of the instrument::

Manual entry of g value: the instrument is ready for one to enter the gravitational acceleration value; **one must modify just the 6 decimal digits of the gravitational acceleration.**

In case one enters a wrong g value: the minimum decimal value is suggested (9,75001); a wrong value is any decimal number that is not between 9,75001 and 9,84999 (inclusive).

(!) **g = 9,80655**

(*) In case of approved instrument the parameter is read only.

(*) CALib SELECTED SCALE'S CALIBRATION (§)

See the paragraph "CALIBRATION".

(§) The value of the parameters within this step, when these are confirmed in the first channel, are configured also for the other channels selected in the **nChAn** step.

(*) In case of approved instrument the parameter is read only.

(*) 0.CALib QUICK ZERO CALIBRATION OF THE SELECTED SCALE

See the paragraph "CALIBRATION".

(*) In case of approved instrument the parameter is read only.

An.out CONFIGURATION OF THE ANALOG OUTPUT

See the paragraph "ANALOGUE OUTPUT (OPTIONAL)".

SERIAL CONFIGURATION OF THE SERIAL PORTS**PC.SEL PC SERIAL SELECTION**

Through this step one can select the PC serial port and therefore invert the serial ports.

COM1 The communication between the indicator and the PC takes place through the **COM1** serial port while the transmission of the data to the printer takes place through the **COM2** serial port.

COM2 The communication between the indicator and the PC takes place through the **COM2** serial port while the transmission of the data to the printer takes place through the **COM1** serial port.

(!) **COM1**

CoM.Prn CONFIGURATION OF THE PRINTER SERIAL PORT**Pr.ModE DATA TRANSMISSION MODE**

One selects the data transmission mode from the PRN serial port.

Pr- no transmission disabled.

tPr enables the printing with TPR printer.

By confirming the "tPr" parameter one is asked (through the "dEF.Pr?" message) to set, for this printer, the default parameters in the steps of the printer serial port ("bAud.Pr", "bit.Pr", "PWr.Prn", "Prn.CtS") and in the steps of printout configuration (see the description of the "dEFAuL" step in the section "FORMATTING DATA AND LAYOUT"): press ENTER/PRINT to confirm or C to cancel; then the "tESt?" message is displayed: press ENTER/PRINT to execute the printout test or C to cancel (see the description of the "PtESt" step in the section "FORMATTING DATA AND LAYOUT").

ALL.Std continuous transmission with standard string.

ALL.Ext continuous transmission with extended string.

PrPC.St transmission of the standard string upon the pressing of the ENTER/PRINT key.

PrPC.EX transmission of the extended string upon the pressing of the ENTER/PRINT key.

Note: The transmission of the standard or extended string upon the pressing of the PRINT key is confirmed by "trAnSM" on the display.

rEPE.6 transmission to 6-digit remote display.

rEPE.4 transmission to 4-digit remote display.

(!) tPr

The printable data and the size of the characters for the “tPr” mode are configurable in the TECHNICAL SET-UP (see the section “PROGRAMMING THE PRINTOUTS”).

For the protocol and transmission mode specifications, see the sections “SERIAL PORT TRANSMISSION MODES” and “TRANSMISSION PROTOCOLS”.

bAud.Pr SET BAUD RATE

By pressing the PRINT key one may select the data transmission speed (measured in Baud = bit/second). The possible values are:

1200/ 2400/ 4800/ 9600/ 19200/ 38400/ 57600/ 115200

(!) 9600

bit.Pr SET PARITY, WORD, STOP BIT

One selects one of the following types of communication protocol which one wants to use in the PRN serial line: n-8-1 / n-8-2 / n-7-2 / E-7-1 / E-7-2 .

(!) n-8-1

PWr.Prn SETTING AUXILIARY POWER SUPPLY AND PRINTER MANAGEMENT

On the indicator board there is a terminal board called V-AUX (auxiliary power supply), thanks to which it is possible to power the devices (for example a printer); refer to the electric scheme for the characteristics.

In this step one programmes the functioning of the auxiliary output and the management of a possible connected printer:

PWr.EXt with instrument on, printer managed and auxiliary output always active.

PWr.int printer managed, auxiliary output active only when the instrument executes a printout.

EXt.oFF printer managed and auxiliary output always active; the start-up characters are sent to the printer, because the printer is considered to be configured in the energy saving mode.

(!) PWr.EXt

on.Prin INSTANTANEOUS ACTIVATION OF AUXILIARY POWER SUPPLY (§)

If the auxiliary power supply has been configured as “PWr.int” in the preceding step, by pressing ENTER/PRINT it is enabled instantaneously (the “onPri” message is blinking on the display); in this mode it is possible, for example, to power a printer to carry out the upkeep operations.

To exit this step (and therefore disable the auxiliary power supply), press any button. The enabling may be carried out quickly also during the weighing, by pressing the ZERO key for a few seconds (except in the REPEATER IN RADIO FREQUENCY functioning mode).

(§) the parameter is not displayed if “PWr.EXt” has been selected in the “PWr.Prn” step or “Pr- no” in the “Pr.ModE” step.

Prn.CtS RTS/CTS STATUS CONFIGURATION (§)

On the printer serial line the indicator has a CTS input (Clear To Send). A device (like a printer) that is slow in processing the data received, can interrupt the transmission temporarily using this signal.

noCtS no signal

CtSL CTS active low (for TPR, DP24 printers)

CtSh CTS active high (for DP190 printers)

EMuCtS emulation of the CTS signal: one is asked to enter the number of characters (nChrS), in 3 digits, which will be transmitted to the printer upon each transmission; then one needs to enter the waiting time in milliseconds (tiME), in 4 digits, between a transmission and another.

The TIME OUT of a printout is a minute, in other words, after a minute that the printout is blocked, it is cancelled.

(!) CtSL

(§) The parameter is not displayed unless “tPr” has been selected in the “Pr.ModE” step.

Pr.ConF CONFIGURATION OF THE PRINTOUTS (§)

See the section “PROGRAMMING THE PRINTOUTS” for the description of all the menu parameters.

(§) The parameter is not displayed unless “tPr” has been selected in the “Pr.ModE” step.

CoM.PC CONFIGURATION OF THE PC SERIAL PORT

PCModE DATA TRANSMISSION MODE

One selects the data transmission mode from the PC serial port:

ondE transmission on external command PC

rEPE.4 transmission to 4 digit remote display.

rEPE.6 transmission to 6 digit remote display.

Prin.St. transmission of standard string when the ENTER/PRINT key is pressed.

Prin.EX transmission of extended string when the ENTER/PRINT key is pressed.

Note: The transmission of the standard or extended string upon the pressing of the ENTER/PRINT key is confirmed by "trAnSM" on the display.

485 transmission with 485 protocol, by confirming with ENTER/PRINT, one is required to enter the machine code (the message "Ad485" appears for an instant): enter a value between 0 and 98.

r.AdC transmission to digital cells: by confirming with ENTER/PRINT, one is required to enter the 485 address (the message "Ad485" appears for an instant), then one has to enter the offset address ("Add.oFF" is displayed for an instant); in this transmission mode it is not possible to communicate with the PC (for this purpose one has to set temporarily the 485 mode and the instrument has to be in the setup environment).

Note: By selecting the protocol r.AdC the instrument automatically sets r.AdC 1 as the filter.

ALL.Std continuous transmission with standard string.

ALL.Ext continuous transmission with extended string.

StAb.St transmission with each weigh with standard string.

StAb.EX transmission with each weigh with extended string.

See the section "PC PORT" for the description of the parameters.

(!) ondE

For the transmission modes and protocol specifications, see the sections "SERIAL PORTS TRANSMISSION MODES" and "TRANSMISSION PROTOCOLS".

bAud SET BAUD RATE

By pressing the PRINT key one may select the data transmission speed (measured in Baud = bit/second). The possible values are:

1200/ 2400/ 4800/ 9600/ 19200/ 38400/ 57600/ 115200

(!) 9600

bit SET PARITY, WORD, STOP BIT

By pressing the ENTER/PRINT key one accesses the selection of the available values: n-8-1, n-8-2, n-7-2, E-7-1, E-7-2.

(!) n-8-1

inPutS INPUT CONFIGURATION (OPTIONAL)

Through this StEP one enters in the submenu for programming the function to be combined to each input (optional, up to 4); to exit press the C key.

Through the ZERO or TARE keys select the input which you want to programme:

inP.b1 INPUT 1

Through this step it is possible to programme the function to be combined with input 1; by closing the input the function is carried out.

The possible functions are the following:

<u>PARAMETER</u>	<u>FUNCTION</u>
nonE	DISABLED FUNCTION
ZErO	ZERO KEY
tArE	TARE KEY

F F KEY
 ENTER ENTER/PRINT KEY
 diS.kEy DISABLING OF KEYBOARD (except the ON/OFF key)
 The **C** key allows to exit without making modifications.
 (!) nonE

inP.b2 INPUT 2**inP.b3** INPUT 3**inP.b4** INPUT 4

The programming of inputs 2, 3 and 4 takes place as described for input 1.

NOTE: In the case in which various inputs are enabled simultaneously only the one with the lower number is taken into consideration.

dEFAu INITIALIZING THE INSTRUMENT

Through this step one can initialize the instrument with the subsequent activation of the default parameters. By pressing ENTER, a confirmation message ("dFLt?") will appear: confirm again with ENTER or exit with any other key.

NOTE: The initialization of the instrument causes a cancellation of the present calibration and the activation of the default parameters. In any case if one exits the setup environment WITHOUT CONFIRMING the modification made, all the parameters of the last saving made will remain (including the calibration).

In case of approved instrument, the default DOES NOT HAVE EFFECT on the metrological parameters (those marked with *).

diAG: TEST OF THE INSTRUMENT FUNCTIONS**PrG.VEr** CHECKING THE SOFTWARE VERSION

By pressing ENTER/PRINT the instrument shows the software version in the XX.YY.ZZ. format.

diV.int CALIBRATION INTERNAL DIVISIONS

By pressing ENTER/PRINT the instrument shows the calibration internal divisions.

AdC.uV MICROVOLTS

By pressing ENTER/PRINT the instrument shows the microvolts relative to the weight on the scale.

In the case the load cell is not connected or faulty it is possible that floating values are shown, or the message "Error" appears, if they exceed the underload / overload value of the converter.

Press the ZERO key to pass to the display of the μV corresponding to the others scales.

Press the C key to pass to the next step.

Note: The maximum voltage that the instrument accepts in input is 30 mV (30000 μV); the weighing system is powered by the indicator at 5 Vdc.

A correct operation will have a value less than 30000 with a weight of full scale capacity on the weighing system.

AdC.Pnt CONVERTER POINTS

By pressing ENTER/PRINT the instrument shows the A/D converter points relative to the weight on the scale.

diSPLA DISPLAY TEST

By pressing ENTER/PRINT the instrument turns on all the display segments and symbols. One exits pressing the C key or the ENTER/PRINT key.

kEyB. KEYBOARD TEST

By pressing the keys one at a time, the relative codes are brought again to the display. One exits pressing the same key three times.

SEr SERIALS TEST

By pressing ENTER/PRINT the instrument displays “ S xy” in which x indicates the status of the printer serial port while y indicates the status of the PC serial port. Both can take on two values:

- 0 Serial port does not work
- 1 Serial port works

During the test one should shortcircuit TXPC with RXPC (in the PC terminal board) and TXPR with RXPR (in the PRN). Furthermore the ASCII “TEST”<CRLF> string is continuously transmitted on both the serial lines.

CtS.St. TEST OF THE CTS STATUS

By pressing ENTER/PRINT one views the status/level of the CTS signal of the printer (on) connected to the PRN serial port.

bt.AdC

Diagnostic check for use of the manufacturer.

PW.AdC

Diagnostic check for use of the manufacturer.

inPutS TEST OF THE I/O EXPANSION BOARD INPUTS (OPTIONAL)

By pressing ENTER/PRINT the instrument displays “ i.bx-y” in which x, y indicate:

- x - the input which is controlling 1, 2, 3, 4; to change the input which one wants to control press the ZERO or TARE keys.
- y - the input status:
 - 0 Disabled input
 - 1 Enabled input
 - Communication error with I/O expansion board or board not present.

Anout ANALOGUE OUTPUT TEST

If the instrument is fitted with the analogue output, through this step one can test if the values of the D/A converter (to be entered at time of calibration) correspond with the relative values of the analogue output (in voltage or in current), see the paragraph “ANALOGUE OUTPUT (OPTIONAL)”.

By pressing ENTER/PRINT the display shows 00000; enter a value between 00000 and 65535 and confirm with ENTER/PRINT; the instrument will supply the corresponding analogue value in output.

To exit the test confirm twice with ENTER/PRINT the same entered value.

SEr.nuM

Diagnostic check for use of the manufacturer.

4. CALIBRATION

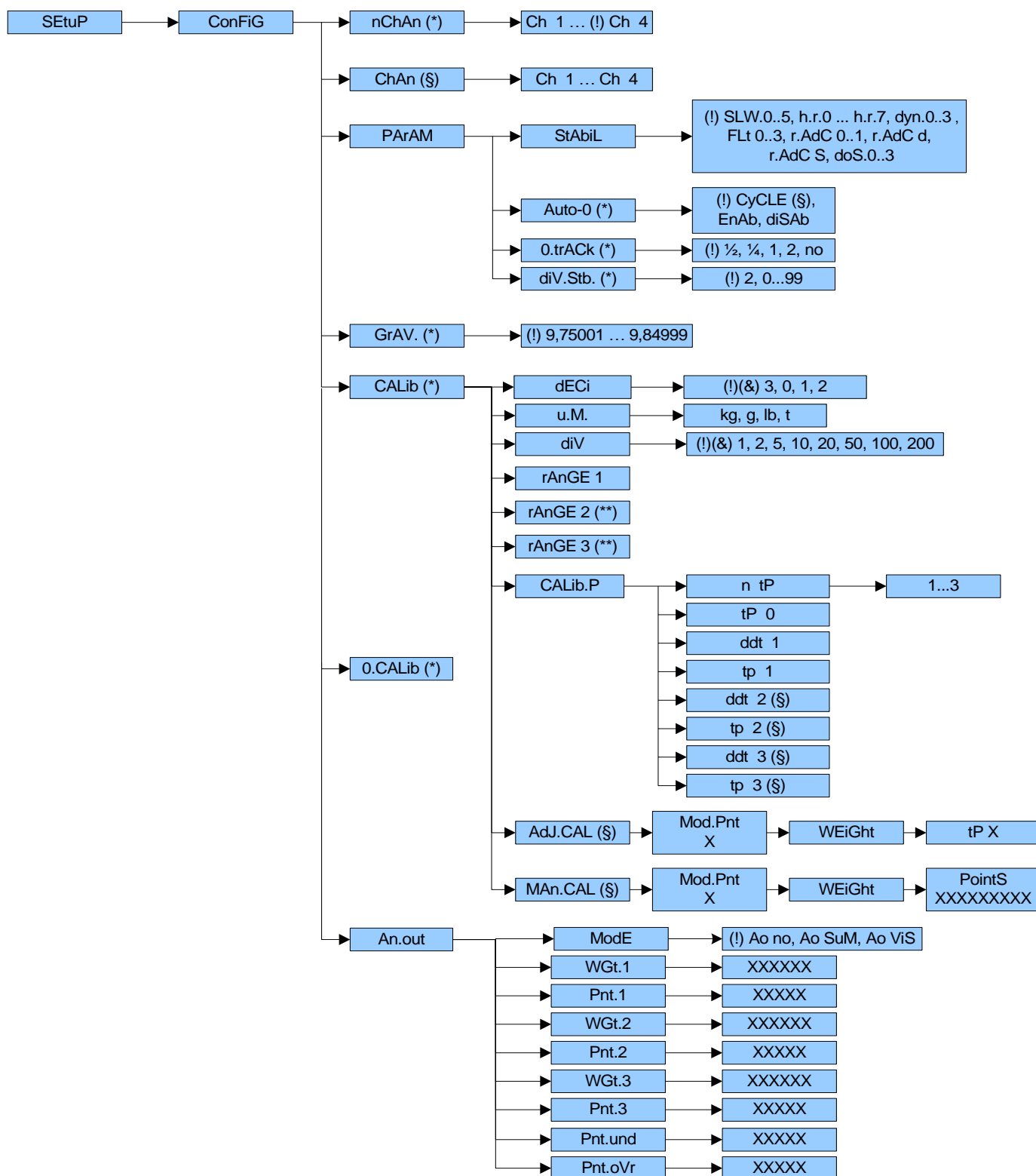

- 1) Enter the SET-UP environment of the scale (when turned on, press the TARE key for an instant while the version is displayed).
- 2) Select the nChAn step and press ENTER/PRINT.
- 3) Enter the number of scales which you want to use (i.e. Ch 1 = 1 connected scale...Ch 4 = 4 connected scales).
- 4) In the ChAn step select the scale which you want to calibrate (i.e. Ch 1 to calibrate scale 1).
- 5) In the GrAV. step set the gravitational acceleration value of the calibration zone.
- 6) Enter in the CALib step.
- 7) Select the "dECi" step and press ENTER/PRINT.

The selectable values are 0.0 (one decimal), 0.00 (two decimals), 0.000 (three decimals), 0 (no decimal); confirm with ENTER/PRINT.

(!) 0.000

- 8) Select the “u.M.” step and press ENTER/PRINT.

Using the ZERO and TARE keys, select the unit of measure **of the scale which is being calibrated.**

(!) kg

- 9) Select the “diV” step and press ENTER/PRINT;

Set the minimum scale division and press ENTER/PRINT (selectable values: 1, 2, 5, 10, 20, 50, 100, 200).

(!) 1

- 10) Select the “rAnGE1” step and press ENTER/PRINT.

Set the capacity of the scale by using the numeric keyboard.

Confirm with ENTER/PRINT.

- 11) Select the “CALib.P” step and ENTER/PRINT.

- 12) Select the “ntP” step and press ENTER/PRINT.

- 13) With the ZERO or TARE keys set the number of points (from 1 to 3, with 1 one does the zero point and one weight point) and press ENTER/PRINT.

- 14) Unload the scale.

- 15) Select the “tP0” (scale zero point) step: press ENTER/PRINT.

- 16) Select the “ddt1” (setting first sample weight) step; press ENTER/PRINT, enter the sample weight value and confirm with ENTER/PRINT.

- 17) Load the sample weight on the scale.

- 18) Select the “tP1” (acquisition of first sample weight) step: press ENTER/PRINT.

NOTE: The number of point of the converter will be shown alternating to the weight acquisition message. If the weight is sufficient stable, the weight acquisition is made, otherwise the display shows “ErMot” and “StorE?”. With ENTER the acquisition is made anyway, with C the display shows “rEtry?”. In this last case with ENTER one can repeat the weight acquisition, with C one can exit from the step.

- 19) **If a calibration point has been set**, once the weight acquisition has been made, the display shows for an instant the value of the internal divisions and then the “ntP” step.

If there are various calibration points, repeat the operations from step 17) for the “ddt2”, “tP2”, “ddt3”, “tP3” points.

N.B.: the calibration points must be increasing (point 1 < point 2 < point 3).

- 20) Repeat the procedure from point 4 for all the connected scales.

- 21) Once the calibration of all the connected scales has been made, press many times the C key until the indicator shows “SAVE?” on the display: confirm with ENTER/PRINT to store and return to weighing.

4.1 CALIBRATION OF WIRELESS PLATFORMS (WWSERF) CONNECTED TO DFWKRPRF

The calibration of the WWSERF platforms connected to the DFWKRPRF indicator can be executed in two different modes: it is possible to calibrate every single platform and then receive the configurations on the repeater, or it is possible to calibrate the platforms by executing the operations on the DFWKRPRF instrument.

4.1.1 CALIBRATION EXECUTED ON THE INDICATOR OF THE WWSERF

It is possible to calibrate each WWSERF by executing the operations on the built-in indicator and then receive the configurations of all the platforms on the DFWKRPRF:

- 1) Enter in the SET-UP environment of the built-in indicator of the platform (when turned on, press the TARE key for an instant while the version is displayed).
- 2) Enter in the **SEtuP** >> **SEriAL** >> **CoM.PC** >> **PCModE** and set the 485 address: the entered value corresponds to the number of the channel associated to that platform.
- 3) Enter in the **SEtuP** >> **ConFiG** step and follow the points from 5) to 19) of the calibration procedure described in the “CALIBRATION” section. The steps “rAnGE 2” and “rAnGE 3” (**) have not to be set.
- 4) Once the calibration of the platform has been executed, press many times the C key until the indicator displays “SAVE?”: confirm with ENTER/PRINT to store and return to weighing.
- 5) Repeat this procedure from the point 1) to 4) for each platform.
- 6) Enter in the SET-UP environment of the DFWKRPRF (when turned on, press the TARE key for an instant while the version is displayed).
- 7) Enter in the in the **SEtuP** >> **SEriAL** >> **CoM.PC** >> **PCModE** step and select the “r.AdC” parameter; then one is

asked to enter the 485 address of the weigh indicator (“Ad485” is displayed for an instant): one has to insert a value greater than the number of platforms connected; once this value is confirmed, one is asked to enter the offset address (“Add.oFF” is displayed for an instant): one has to confirm the value 00.

- 8) Enter in the **SEtuP >> ConFiG >> nChAn** step, select with the ZERO or TARE key the number of channels that have to be calibrated and confirm with ENTER/PRINT; the “r.CFG?” message is displayed:
 - by pressing ENTER/PRINT the parameters of calibration of each connected platform are received (the “WAit” message is displayed for an instant, then for each channel the “r.CFG.X” message is shown); the “ok” message confirm the reception of all the data (if it is not possible to receive the data from a platform, the “Error” message is displayed);
 - by pressing C one exits from the step without receiving the data.
- 9) Enter in the **SEtuP >> ConFiG >> PArAM > StAbiL** step and set one of the filters for the weighing with WWSERF: “r.AdC S”, “r.AdC d”, “r.AdC 1” or “r.AdC 0”.
- 10) Press many times the C key until the indicator displays “SAVE?”: confirm with ENTER/PRINT to store and return to weighing.

4.1.2 CALIBRATION EXECUTED ON THE DFWKRPRF

In the case in which the calibration of the WWSERF platforms requires the use of sample weights having dimensions such that it is not possible to operate on the built-in indicator, it is necessary to follow this procedure that allows to execute the calibration of each platform directly from the DFWKRPRF indicator:

- 1) For each indicator of the platforms, enter in the SET-UP environment (when turned on, press the TARE key for an instant while the version is displayed) and set the 485 address in the **SEtuP >> SEriAL >> CoM.PC >> PCModE >> 485** step: the entered value corresponds to the number of the channel associated to that platform. Press many times the C key until the indicator displays “SAVE?”: confirm with ENTER/PRINT to store.
- 2) Enter in the SET-UP environment of the DFWKRPRF (when turned on, press the TARE key for an instant while the version is displayed).
- 3) Enter in the **SEtuP >> ConFiG >> nChAn** and select with the ZERO or TARE key the number of channels that have to be calibrated; confirm with ENTER/PRINT.
- 4) Enter in the **SEtuP >> ConFiG >> PArAM > StAbiL** step and set one of the filters for the weighing with WWSERF: “r.AdC S”, “r.AdC d”, “r.AdC 1” or “r.AdC 0”.
- 5) Enter in the in the **SEtuP >> SEriAL >> CoM.PC >> PCModE** step and select the “r.AdC” parameter; then one is asked to enter the 485 address of the indicator (“Ad485” is displayed for an instant): one has to insert a value greater than the number of platforms connected; once this value is confirmed, one is asked to enter the offset address (“Add.oFF” is displayed for an instant): one has to confirm the value 00.
Press many times the C key until the indicator displays “SAVE?”: confirm with ENTER/PRINT to store.
- 6) To calibrate one platform from the DFWKRPRF instrument, one has to enter in the SET-UP environment of the corresponding built-in indicator while the weight repeater is on: the “SEt.ChX” message is displayed on the repeater, in which X is the number of the platform connected; then the steps of the setup environment of the WWSERF indicator are displayed on the DFWKRPRF. The keys pressed on the DFWKRPRF are repeated on the indicator of the platform.
- 7) Enter in the **SEtuP >> ConFiG** step and follow the points from 5) to 19) of the procedure described in the “CALIBRATION” section. The steps “rAnGE 2” and “rAnGE 3” (***) have not to be set. Once the calibration has been executed, press many times the C key until the indicator displays “SAVE?”: confirm with ENTER/PRINT to store and return to weighing.
- 8) Repeat the 6) and 7) points of this procedure for each connected platform.
- 9) Enter in the **SEtuP >> ConFiG >> nChAn** step in the SET-UP environment of the DFWKRPRF and confirm the number of channels with ENTER/PRINT; the “r.CFG?” message is displayed:
 - by pressing ENTER/PRINT the parameters of calibration of each connected platform are received (the “WAit” message is displayed for an instant, then for each channel the “r.CFG.X” message is shown); the “ok” message confirm the reception of all the data (if it is not possible to receive the data from a platform, the “Error” message is displayed);
 - by pressing C one exits from the step without receiving the data.
- 10) Press many times the C key until the indicator displays “SAVE?”: confirm with ENTER/PRINT to store and return to weighing.

4.2 IN CASE THE ZONE OF USE IS DIFFERENT FROM THE CALIBRATION ZONE

ONE SHOULD:

- 1) Enter in the SET-UP environment of the scale (when turned on, press for an instant the TARE key while the version is displayed).
- 2) Enter in the **SEtuP** >> **ConFiG** >> **GrAV.** step and select the CALIBRATION ZONE.
- 3) Carry out the calibration as previously described.
- 4) Save and exit from the SET-UP environment (press many times the C key until the indicator shows "SAVE?" in the display and confirm with ENTER/PRINT).
- 5) Enter the SET-UP environment of the scale and enter the **SEtuP** >> **ConFiG** >> **GrAV.** step and set the gravitational acceleration value of the ZONE OF USE.
- 6) Save and exit the SET-UP environment.
- 7) The weight error caused by the error of a different gravitational attraction value between the calibration zone and the zone of use is corrected automatically.

With APPROVED instrument, when the slow start-up, the value of the zone of use or the gravitational acceleration value is displayed.

4.3 QUICK CALIBRATION OF ZERO

It is useful to calibrate just the point of ZERO when a permanent tare weight is put onto the platform (for example a roller unit).

- 1) Enter in the SET-UP environment of the scale (when turned on, press the TARE key for an instant while the version is displayed).
- 2) In the ChAn step select the scale to be calibrated.
- 3) Enter in the **0.CALib** step and press ENTER/PRINT key (the display shows "CAL.0?").
- 4) Put the tare on the scale and press ENTER/PRINT key to confirm the operation.
- 5) Once the zero calibration is made, press many times the C key until the indicator shows "SAVE?" in the display: confirm with ENTER/PRINT to store and return to weighing.

4.4 QUICK CALIBRATION OF A DEFINITE WEIGHT

It is useful to recalibrate the point of a definite weight except 0 weight when the user wants to recalibrate the scale.

- 1) Enter in the SET-UP environment of the scale (when turned on, press for an instant the TARE key while the firmware version is displayed).
 - 2) Enter in the **SEtuP** >> **ConFiG** >> **CALib** >> **AdJ.CAL (§)** step and press ENTER/PRINT key (the display shows "Mod.Pnt").
 - 3) Enter the number of the sample weight to be recalibrated (between 0 and 3) and press ENTER/PRINT key to confirm the value; the "WEiGht" message is displayed for an instant, then enter the weight value of the selected sample and confirm by pressing ENTER/PRINT.
 - 4) The display shows "tP" followed by the number of the sample weight to be recalibrated; put the weight on the scale, wait a few seconds and press ENTER/PRINT.
 - 5) Once the reacquisition of the sample weight has been made, the display shows for an instant the value of the internal divisions and then the indicator exits from the "AdJ.CAL" step; then press many times the C key until the display shows "SAVE?": confirm with ENTER/PRINT to store and return to weighing.
- (§) The step is displayed only if the number of points of calibration has been entered or if one has selected the "r.AdC" parameter in the **SEtuP** >> **SEriAL** >> **CoM.PC** >> **PCModE** step.

4.5 MANUAL CALIBRATION OF A DEFINITE WEIGHT

It is useful to manually recalibrate the point of a definite weight except 0 weight when the user knows the number of points of the converter and wants to recalibrate the scale.

- 1) Enter in the SET-UP environment of the scale (when turned on, press for an instant the TARE key while the firmware version is displayed).
- 2) Enter in the **SEtuP** >> **ConFiG** >> **CALib** >> **MAn.CAL (§)** step and press ENTER/PRINT key (the display shows "Mod.Pnt").
- 3) Enter the number of the sample weight to be manually recalibrated (between 0 and 3) and press ENTER/PRINT key to confirm the value; the "WEiGht" message is displayed for an instant, then enter the weight value of the selected sample weight and confirm by pressing ENTER/PRINT.

- 4) The display shows "PointS" for an instant, then enter the number of points of the converter and confirm by pressing ENTER/PRINT. Once this value has been acquired, the indicator exits from the "Man.CAL" step; then press many times the C key until the display shows "SAVE?": confirm with ENTER/PRINT to store and return to weighing.
- (§) The step is displayed only if the number of points of calibration has been entered or if one has selected the "r.AdC" parameter in the **SEtuP >> SEriAL >> CoM.PC >> PCModE** step.

5. DISPLAY OF THE GRAVITY ACCELERATION AND CORRECTION OF THE WEIGHING ERROR due to the different gravity acceleration between calibration zone and utilisation zone

This instrument conforms to the laws currently in force regarding non-automatic weighing instruments. Such g-sensitive instruments are influenced by the gravitational acceleration value "g" of the utilisation zone, hence it is compulsory to indicate, with a label or on the display, the value of "g" of the utilisation zone where the weighing machine can be used. Therefore a special programme has been created to compensate for any differences in the gravitational attraction between the place where the weighing machine is calibrated and the place of utilisation, eliminating in this way the error entered on the weight.

During configuration the "g" values relative to the utilisation zone and to the zone of calibration are entered at a certain programming step which eliminates the weight error introduced by the different gravitational attraction value.

When turned on, by pressing the **ZERO** key, the instrument displays, after the name and the installed software version, the "g" value relative to the gravitational zone of use for a few seconds.

6. SERIAL OUTPUTS

The instrument has two bidirectional serial outputs, which have the output in ASCII code compatible with the majority of printers, remote displays, PCs and other devices.

6.1 PC SERIAL PORT

It is bi-directional (full duplex) and uses an RS232 for transmitting data. It is mainly used to connect computers, PLCs, additional remote displays, and it can be converted into RS485 (options). The transmission speed may be selected in the SET UP among these: 1200, 2400, 4800, 9600, 19200, 38400, 57600, 115200 Baud (bit/sec.).

RS232 CONNECTIONS FROM PC TO INDICATOR:

	PC 9pin (male)	PC 25pin (male)	INDICATOR Serial line	CASE 9pin (female)	STANDARD CABLE
RX	2	3	TXPC	2	Pink
TX	3	2	RXPC	3	Yellow
GND	5	7	GND	5	Grey

Below is shown the connection in RS232 between the GLH60R WEIGHT REPEATER and the indicator:

	GLH60R Serial line	DFW03 Serial line	STANDARD CABLE
RX	2	TX2	Pink
GND	4	GND	Grey

Please find below the connection between the radio frequency module and the indicator powered at 12 Vdc:

	RF MODULE 9pin (female)	INDICATOR Serial line	INDICATOR 12 Vdc POWER	CABLE STANDARD
RX	3	TXPC		Pink
TX	2	RXPC		Yellow
GND	5			Grey
GND	5		0 Vdc	White
(8-30 Vdc)	9		12 Vdc	Green or Brown

The transmission of data through the PC serial port can be configured in different ways, according to the setting of the "PCMode" step in the SET-UP environment.

Refer to the section "SERIAL PORT TRANSMISSION MODES" for the functioning specifics.

Below is the RS485 connection of the indicator through DF485 board (optional):

	INDICATOR (DF485 board)
Line 485 +	A(+)
Line 485 -	B(-)

6.2 PRN SERIAL PORT

It is bi-directional (full duplex) and uses an RS232/TTL for transmitting data, selectable through the jumper on the board; it is mainly used to connect to printers, computers and PLCs. The transmission speed may be selected in the SET UP among these: 1200, 2400, 4800, 9600, 19200, 38400, 57600, 115200 Baud.

Please find below the connection between the TPR printer and the indicator:

TPR Terminal board	INDICATOR Serial line	STANDARD CABLE
GND	GND	Black
RTS	CTS	Yellow
RX	TXPR	Grey
		Blue (not connected)
Printer power supply		
+ VP	+ V AUX	Red
GND	- V AUX	Black

Below is the connection in RS232 between the PC and the indicator:

PC 9pin (male)	PC 25pin (male)	INDICATOR Serial line	STANDARD CABLE
GND 5	7	GND	Grey
RX 2	3	TXPR	Pink

Below is shown the connection in RS232 between the GLH60R WEIGHT REPEATER and the indicator:

GLH60R Serial line	INDICATOR Serial line	STANDARD CABLE
RX 2	TX0	Pink
GND 4	GND	Grey

6.3 CONNECTION OF THE RADIO MODULE ON DFWLAPKR

Below are shown the connections between the radio frequency module and the DFWLAPKR indicator:

INDICATOR TTL PORT	RADIO MODULE
1 +5V	1 +5V
2 GND	2 GND
3 TX	4 RX
4 RX	3 TX

6.4 SERIAL PORT TRANSMISSION MODES

6.4.1 PC PORT

Please find below the various selectable serial weight transmission modes of the PC serial port through the corresponding "PCModE" step of the SET-UP environment.

- **TRANSMISSION REQUESTED FROM AN EXTERNAL DEVICE** ("ondE" parameter)
In this case the indicator waits for a command before transmitting (see the section "FORMAT OF THE SERIAL COMMANDS").
With Baud rate at 9600, through the READ command, it is possible to make up to 10-11 requests per second, while with Baud rate at 115200 one can arrive at 16.
The transmission works with weight $<$, $=$, $>$ 0 with approved or unapproved instrument.
NOTE: This protocol is active also in the other functioning modes, only on the PC serial output.
 - **4 – 6 DIGIT REMOTE DISPLAY TRANSMISSION** ("rEPE.4" and "rEPE.6" parameter)
The weight displaying takes place both in the indicator as well as in a weight repeater of 4 or 6 digits (normally the capacity will be properly set up for a correct displaying).
NOTE: Independently from the set transmission speed it's possible to obtain up to 6 transmissions per second.
 - **TRANSMISSION WHEN THE PRINT KEY IS PRESSED** ("Prin.St", "Prin.EX" parameter)
The instrument communicates the weight data through the serial port when the ENTER/PRINT key is pressed (except for in the TOTALIZER mode where one should press the MODE key).
For non approved instruments:
 - The transmission takes place if the weight is stable and the gross weight is \geq of a division, otherwise the display shows the "LOW" message
 - Reenabling the transmission depends on how the "rEACt" step has been set in the SET-UP environment (passing by zero of the GROSS weight, weight instability or always).
 For approved instruments:
 - The transmission takes place if the weight is stable and the gross weight is ≥ 20 divisions for each connected scale, otherwise the display shows the "LOW" message.
 - Reenabling the transmission depends on how the "rEACt" step has been set in the SET-UP environment (passing by zero of the GROSS weight, weight instability or always).
 The data is transmitted using the standard string (Prin.St) or the extended string (Prin.EX); see the section "TRANSMISSION PROTOCOLS" for the description of the two strings.
- NOTES:**
- The transmission is confirmed by the the "trAnSM" message on the display or from the "Print" or "tot" messages in the case in which the transmission takes place at the same time of the printing or totalisation.
 - In any case it's possible to receive data through the transmission commands upon request.
 - With an unstable weight the display shows the "unStAb" message.
 - If the transmission has not been reenabled the display shows the "no.0.unS" message.
 - In any case it's possible to receive the data through the transmission commands upon request.
- **TRANSMISSION IN RS 485 SERIAL MODE** ("485" parameter)
The protocol is the same as the transmission upon request ("ondE" parameter), except that the instrument responds only if its machine code is the one requested (before the request the machine code must be put, I.E. 00READ<CRLF>).
If a broadcast address command (99) is received no answer is given. If the command is correct it is executed anyways.
 - **TRANSMISSION IN R.ADC MODE** ("r.AdC" parameter)
The protocol is used for the communication with the WWSERF platforms.
 - **CONTINUOUS TRANSMISSION** ("ALL.Std" and "ALL.ExT" parameter)
This mode is used for interfacing to the PC, remote displays and other devices which request a constant updating of the data independently from the weight stability.
If one selects this mode for the PC, independently from the set transmission speed one can obtain up to 4 transmissions per second.

If one selects this mode for the PRINTER port, the instrument transmits the data in relation to the set transmission speed:

- With Baud rate at 9600 one can obtain up to 24 transmissions per second.
- With Baud rate at 115200 one can obtain up to 26 transmissions per second.

The transmission works with weight $<$, $=$, $>$ 0 with approved or unapproved instrument.

The data is transmitted using the standard string (ALL.Std) or the extended string (ALL.EXt); see the section "TRANSMISSION PROTOCOLS" for the description of the two strings.

- **TRANSMISSION ON STABILITY** ("StAb.St" and "StAb.EX" parameter)

Each time a weight on the scale becomes stable, a communication string is transmitted on the PC serial port.

For non approved instruments:

- The transmission takes place if the weight is stable and the gross weight is $>$ 10 divisions.
- Reenabling the transmission depends on how the "rEACt" step has been set in the SET-UP environment (passage by zero of the GROSS weight or instability of the weight of 10 divisions; by choosing "always" it works upon instability).

For approved instruments:

- The transmission takes place if the weight is stable and the gross weight is $>$ 20 divisions for each connected scale.
- Reenabling the transmission depends on how the "rEACt" step has been set in the SET-UP environment (passage by zero of the GROSS weight or instability of the weight of 20 divisions; by choosing "always" it works upon instability).

The data is transmitted using the standard string (StAb.St) or the extended string (StAb.EX); see the section "TRANSMISSION PROTOCOLS" for the description of the two strings.

6.4.2 PRN PORT

Please find below the various selectable serial weight transmission modes of the PRN serial port through the corresponding "Pr.ModE" step of the SET-UP environment.

- **TRANSMISSION TO PRINTER** ("tPr" parameter): requests the use of the print key on the indicator (prints upon request of the operator). The print command is inhibited if the weight is in motion and in all other circumstances in which the data is not valid (see the section "EXECUTION OF THE PRINTOUTS", **USER MAN.REF.**).
- **CONTINUOUS TRANSMISSION** ("ALL.Std" and "ALL.EXt" parameter): see the "ALL.Std" and "ALL.EXt" modes of the PC port.
- **TRANSMISSION OF THE PC STRING UPON PRESSURE OF THE PRINT KEY** ("PrPC.St" and "PrPC.EX" parameter): see the "Prin.St" or "Prin.EX" mode of the PC port.
- **TRANSMISSION TO 4 – 6 DIGIT REMOTE DISPLAY** ("rEPE.4" and "rEPE.6" parameter): see the "rEPE.4" and "rEPE.6" mode of the PC port.

THE CONNECTION AND THE SOFTWARE CONFIGURATION OF THE SERIAL OUTPUTS MUST BE CARRIED OUT BY TECHNICAL PERSONNEL WHO KNOW THE PROCEDURES ON THE BASIS OF THE NEEDS OF THE USER.

6.5 FORMAT OF THE SERIAL COMMANDS

Version reading command

[CC]VER<CR LF>

Instrument response: [CC]VER,vvv,DFWKR06<CR LF>

In which: vvv is the firmware version

Weight reading command (reception of the standard string)

[CC]READ<CR LF>

Instrument's answer: STANDARD STRING (see the section "TRANSMISSION PROTOCOLS").

Extended weight read command (reception of the extended string)

[CC]REXT<CR LF>

Instrument response: EXTENDED STRING (see the section "TRANSMISSION PROTOCOLS").

Extended weight read command (reception of the extended string) with date and time

[CC]REXD<CR LF>

Instrument response: EXTENDED STRING (see the section "TRANSMISSION PROTOCOLS").

Command for changing the displayed data

[CC]WVIS,VV<CR LF>

In which:

VV= code which corresponds to the desired visualisation

VV= 00: scale 1 weight data

01: scale 2

02: scale 3

03: scale 4

04: scale 1 + scale 2

05: scale 1 + scale 3

06: scale 1 + scale 4

07: scale 2 + scale 3

08: scale 2 + scale 4

09: scale 3 + scale 4

10: scale 1 + scale 2 + scale 3

11: scale 1 + scale 2 + scale 4

12: scale 1 + scale 3 + scale 4

13: scale 2 + scale 3 + scale 4

14: scale 1 + scale 2 + scale 3 + scale 4

Instrument answer: [CC]OK<CR LF> if the command has been RECEIVED; the instrument answer does not imply that the instrument executes the command.

Command for reading the data relative to the weigh under way

[CC]WSTA<CR LF>

Instrument answer:

[CC]tt,PPTTTTTTTTTT,nn,NNNNNNNNNN,QQQQQQQQQQ,ii,IIIIIIIII,oo,OOOOOOOOOO,UU<CR LF>

In which:

tt : number of tare totalisations (0 if the tare is neither a totaliser one a manual one or one from the database)

, : comma character

PP : type of tare: PT = manual tare or from database

NO CHARACTER = semiautomatic tare

TTTTTTTTTT : stored tare value

, : comma character

nn : number of executed totalisations

, : comma character

NNNNNNNNNN : accumulated weight

, : comma character

QQQQQQQQQQ : input/output tare value

,	:	comma character
ii	:	number of input weighs
,	:	comma character
IIIIIIII	:	accumulated input weight
,	:	comma character
oo	:	number of output weighs
,	:	comma character
000000000	:	accumulated output weight
,	:	comma character
UU	:	unit of measure of the transmitted values
CR	:	ASCII 13 character (carriage return)
LF	:	ASCII 10 character (line feed)

Command for reading stored vehicle total data

[CC]WTOT<CR LF>

Instrument answer:

[CC]vv, VVVVVVVV, ii, IIIIIIII, oo, 00000000, UU<CR LF>

in which

vv	:	number of weighed vehicles
,	:	comma character
VVVVVVVV	:	weight total of weighed vehicles
,	:	comma character
ii	:	number of input weighs
,	:	comma character
IIIIIIII	:	accumulated input weigh
,	:	comma character
oo	:	number of output weighs
,	:	comma character
000000000	:	accumulated output weigh
,	:	comma character
UU	:	unit of measure of the transmitted values
CR	:	ASCII 13 character (carriage return)
LF	:	ASCII 10 character (line feed)

Reading command of weight accumulation in the tare total

[CC]MVOL<CR LF>

Instrument response: STANDARD STRING (see the section "TRANSMISSION PROTOCOLS").

Reading command of converter points relative to the weight

[CC]RAZF<CR LF>

Instrument response:

The string varies depending on the configured channels:

Channels Transmitted String

- 1 hh,pppppppppp,uu<CR LF>
- 2 hh,pppppppppp,pppppppppp,uu<CR LF>
- 3 hh,pppppppppp,pppppppppp,pppppppppp,uu<CR LF>
- 4 hh,pppppppppp,pppppppppp,pppppppppp,pppppppppp,uu<CR LF>

In which:

hh	"RZ"
,	comma
pppppppppp	10 digits which identify converter points relative to the channel. Repeated for each configured channel.
,	comma
uu	"vv" unit of measure (Value in converter points relative to the weight).
<CR LF>	Carriage Return + Line Feed (ascii decimal 13 e 10).

Command for setting display visualisation interval

[CC]DINTNNNN<CR LF>

in which: NNNN is the visualisation interval (in milliseconds), expressed in ascii hex character; for example, in order to set a visualisation time of 2 seconds (2000 milliseconds, which converted into hex it becomes 07D0), the command becomes DINT07D0<CR><LF>.

By setting a time equal to zero, the message transmitted with the DISP command remains permanently shown on the display.

Instrument response: [CC]OK<CR LF>

With approved instrument:

The minimum settable time is 1 millisecond (0001HEX), and maximum settable time is 5 seconds (5000 milliseconds, 1388 HEX).

PC confirmation command

[CC]PCOK<CR LF>

The indicator shows on the display the "-PCOK-" message for about 2 seconds.

Instrument response: [CC]OK<CR LF>.

Serial command which supplies the indicator status

[CC]STAT<CR LF>

Instrument response: [CC]STATXX<CR LF> in which XX is a decimal value which supplies the status of the indicator; the possible values are:

XX indicator status

- 00 normal scale status
- 01 normal scale status in input
- 02 instrument in technical set-up
- 03 in boot phase
- 04 in rx/tx set-up phase
- 05 in test phase of the serial ports
- 06 in print test
- 07 in firmware update phase
- 08 in stand-by
- 09 in automatic zero phase
- 11 in optoisolated inputs test phase

Key pressure simulation command

[CC]KEYPXX<CR LF>

in which XX is the code of the pressed key:

- 00: MODE key;
- 01: F key.
- 02: ENTER/PRINT key;
- 03: TARE key;
- 04: scale ZERO key;
- 05: numeric 0 key;
- 06: numeric 1 key;
- 07: numeric 2 key;
- 08: numeric 3 key;
- 09: numeric 4 key;
- 0A: numeric 5 key;
- 0B: numeric 6 key;
- 0C: numeric 7 key;
- 0D: numeric 8 key;
- 0E: numeric 9 key;
- 0F: INFO key;
- 10: C key;

Instrument response: OK<CR LF>: accepted command.

In case the simulated key has two linked functions (key briefly pressed or at length, like the TARE key), if the KEYP command is followed by the release command of the (KEYR) key within a maximum time of 1,5 seconds, the simple function will be executed (key briefly pressed); otherwise the second function will be made (key pressed at length).

Key release simulation command

[CC]KEYR<CR LF>

Response: [CC]OK<CR LF>

Key disabling command

[CC]KEYEt<CR LF>

t → E to enable keys

t → D to disable keys

Response:

[CC]OK<CR LF>

Key status command

[CC]KEYE<CR LF>

Response:

[CC]KEYEE<CR LF> if the keyboard is enabled

[CC]KEYED<CR LF> if the keyboard is disabled

Tare lock command

[CC]TLCKt<CR LF>

t → E to lock the tare

t → D to unlock the tare

Response:

[CC]OK<CR LF>

Tare status command

[CC]TLCK<CR LF>

Response:

[CC]TLCKE<CR LF> if the tare is locked.

[CC]TLCKD<CR LF> if the tare is unlocked.

NOTE: The instrument does not transmit the OK answer to the following short commands: P, Q, T, W, X, Z.

Scale information reading: [CC]RALL<CR LF>

Instrument answer:

SS,B,NNNNNNNUM,LLLLLLLUM,YYTTTTTTTTTUM,XXXXXXXXXUM,SSS,AAA,CCC,TTT,XXXXX-YYYYYY<CR LF>.

in which:

SS	UL	Underload
	OL	Overload
	ST	Stability of the display
	US	Unstability of the display
	TL	Active inclination input
B		Number of platform on which the totalisation has been made.
NNNNNNNUM		Net weight with unit of measure.
LLLLLLLUM		Gross weight with unit of measure.
XXXXXXXXXUM		Last net weight totalized with unit of measure
SSS		Scale status: 000 start-up
		001 weighing
		002 selection of functioning mode
		003 generic menu
		004 set-up menu

005 user menu
 006 exit from set-up
 007 Update Firmware status
 008 setting of user default
 009 setting of technical default
 010 switch channel
 011 setting of technical default
 012 Test of the PC serial ports
 013 Test of the PRN serial ports

AAA Counter of pressed keys.
 CCC Code of last key pressed.
 TTT Counter of totalisations.
 XXXXX Last rewriting number stored in the Alibi memory.
 YYYYYY Last weigh number stored in the Alibi memory.

LEGEND

[CC]= instrument code, e.g.. 00 (only with RS485 protocol).

<CR LF>= Carriage Return + Line Feed (ASCII characters 13 and 10).

SERIAL ERRORS

Upon each serial command received the instrument transmits a response which may be a response to a command (see the command description) or the indication of the command error:

ERR01<CR LF> it is shown when a correct command is transmitted from the PC to the indicator however it is followed by letters inserted involuntarily (I.E.: READF TARES...).

ERR02<CR LF> it is shown when a correct command is transmitted from the PC to the indicator, but containing wrong data.

ERR03<CR LF> it is shown when an unallowed command is transmitted. It may be a command not used in the selected functioning mode or the command reaches the indicator in the instant in which the keyboard buffer is already occupied by another command.

ERR04<CR LF> it is shown when an inexistent command is transmitted.

6.6 TRANSMISSION PROTOCOLS

The weight data transmission on the serial ports may take place in two formats:

STANDARD STRING

[CC]SS,VV,PPPPPPP,UU < CR LF >

in which:	[CC]	INSTRUMENT CODE IN THE FORMAT OF TWO ASCII DECIMAL DIGITS ONLY IF THE 485 PROTOCOL HAS BEEN SELECTED (FOR EXAMPLE 00)
	SS	NV: invalid weight ST: stable weight US: unstable weight
	,	Comma character
	VV	00: scale 1 weight data 01: scale 2 02: scale 3 03: scale 4 04: scale 1 + scale 2 05: scale 1 + scale 3 06: scale 1 + scale 4 07: scale 2 + scale 3 08: scale 2 + scale 4 09: scale 3 + scale 4 10: scale 1 + scale 2 + scale 3 11: scale 1 + scale 2 + scale 4 12: scale 1 + scale 3 + scale 4 13: scale 2 + scale 3 + scale 4 14: scale 1 + scale 2 + scale 3 + scale 4
	,	Comma character
	PPPPPPP	weight value
	,	Comma character
	UM	unit of measure
	<CR LF>	Carriage Return + Line Feed (ascii decimal 13 and 10).

EXTENDED STRING

	Scale 1	Scale 2	Scale 3	Scale 4	
[CC]	hh,NNNNNNNNNN	hh,NNNNNNNNNN	hh,NNNNNNNNNN	hh,NNNNNNNNNN	uu,(dd/mm/yybbhh:mm:ss "NO DATE TIME") < CR LF >

in which: **[CC]** INSTRUMENT CODE IN THE FORMAT OF TWO ASCII DECIMAL DIGITS JUST IN CASE THE 485 PROTOCOL IS SELECTED (FOR EXAMPLE 00)

hh UL Underload
 OL Overload
 ST Stability of display
 US Instability of display
 TL Active inclination input

, Comma character

NNNNNNNNNN Net weight on 10 characters including possible sign and decimal point

, Comma character

...

uu Unit of measure "Kg" "bg" "bt" "lb

, Comma character (only with REXD command)

dd/mm/yy Date in the "dd/mm/yy" format (only with REXD command)

bb 2 space characters, 32 decimal ascii character (only with REXD command)

hh:mm:ss Time in the "hh:mm:ss" format (only with REXD command)

<CR LF> Carriage Return + Line Feed (ascii decimal 13 and 10).

The insignificant digits of the net will be filled with spaces (space character, 32 decimal ascii code character)

In the case in which the optional "Real Time Clock" board is not detected, the weight is transmitted but not the date and time; "NO DATE TIME" is in its place.

7. PROGRAMMING THE PRINTOUTS

If in the set-up environment the presence of the printer has been configured correctly, the indicator carries out the print functions; each functioning mode has specific printouts, shown in the section "EXECUTION OF THE PRINTOUTS" (**USER MAN.REF.**). In any case, it is possible to define some printing fields, the size of the characters, a heading and other options depending on the functioning mode.

In the "Pr.ModE" step of the set-up environment it is possible to select the TPR printer; see the following steps for all the printing options.

- 1) Enter the SET-UP environment of the scale (when turned on, press for an instant the TARE key while the firmware version is displayed).
- 2) Select the **SEtuP >> SEriAL >> CoM.Prn >> Pr.ModE** step and press ENTER/PRINT.
- 3) Select the "tPr" printer and press ENTER/PRINT.
- 4) In the section "SET-UP ENVIRONMENT" see the descriptions of the "bAud.Pr", "bit.Pr", "PWr.Prn", "on.Prin" and "Prn.CtS" steps for configuring the baud rate, the number of transmission bits, the printer's power supply and the CTS signal.
- 5) Select the "**Pr.ConF**" step and press ENTER/PRINT: one enters the **PROGRAMMING MENU OF THE PRINTOUTS**. Below is the description of the steps.
- 6) Once the setting have been made, press the C key various times until the indicator shows "SAVE?" In the display: confirm with ENTER/PRINT to memorize and return to weighing.

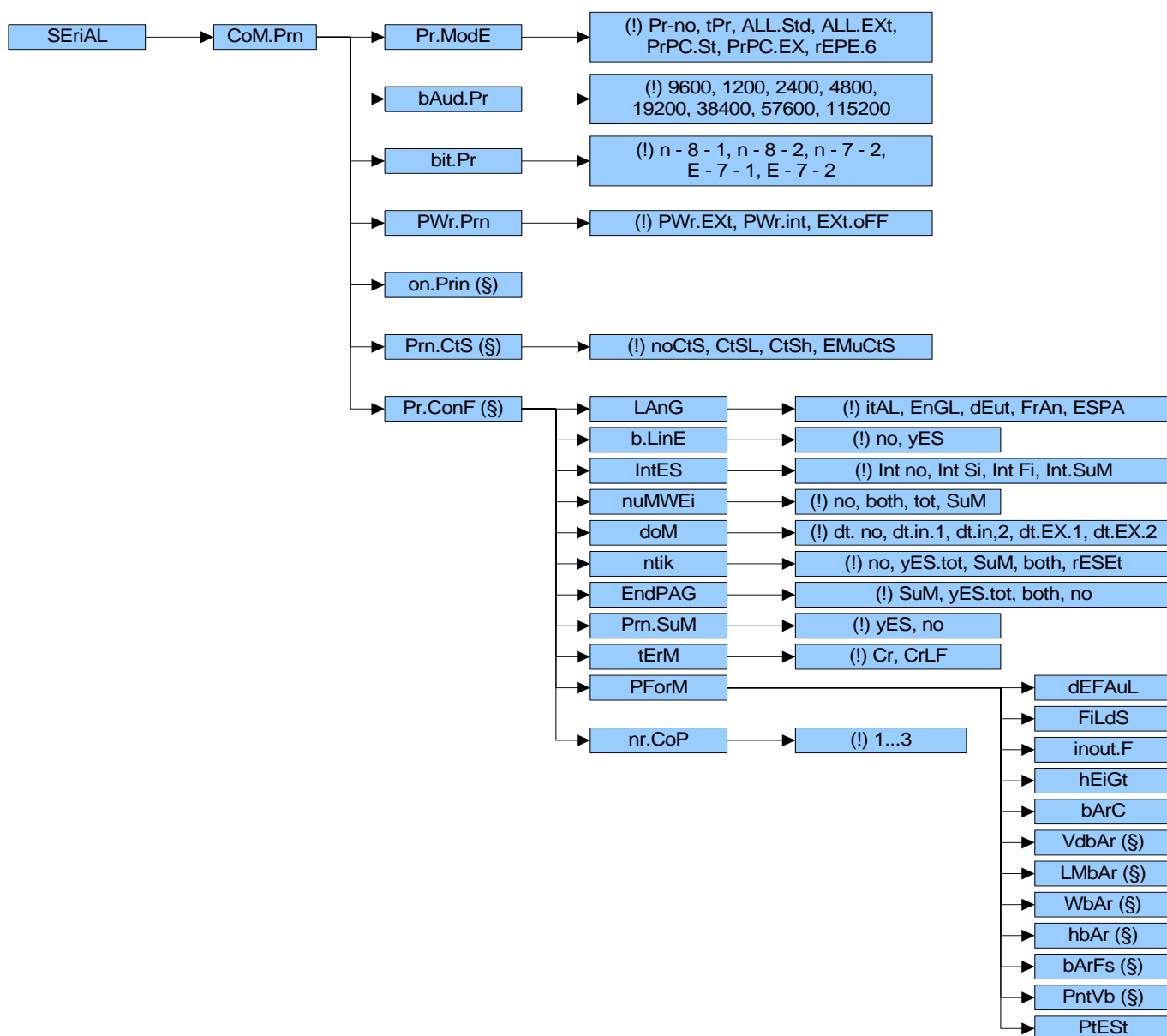

Pr.ConF CONFIGURATION OF THE PRINTOUTS (§)

In this step one enters the print programming submenu.

(§) The parameter and all its submenus are displayed only if the “tPr” parameter has been selected in the “Pr.ModE” step.

LAnG PRINTOUT LANGUAGE

One selected the language shown in the printouts:

itAL Italian
EnGL English
dEut German
FrAn French
ESPA Spanish

(!) itAL

b.LinE PRINTS EMPTY LINE

When using the TPR printer, a blank line is printed at the beginning of each printout, in order to preheat the thermal printer head.

no no blank line
yES at the beginning of each printout an empty line is inserted
(!) no

IntES PRINTING HEADING

Int no heading is not printed
Int Si prints heading only upon the first totalisation
Int Fi prints heading in all the totalisations
Int.SuM prints heading in all the totalisations and in the vehicle total

ROSSI MARCO S.R.L. VIA DELLA PACE 18 GENOVA

The selection of the “Int Si” and “Int Fi” parameters includes the configuration of the heading (see the section “PRINTING THE HEADING”). If the heading has already been configured one needs to reconfirm the heading lines.

(!) Int no

nuMWEi PRINTS NUMBER OF WEIGHS

no does not print number of weighs
tot prints number of weighs only in the totalisation
SuM prints number of weighs in the vehicle total
both prints number of weighs in the total as well as in the totalisation

The number of weighs is reset with each printout of the vehicle total.

(!) no

WEIGH	1
30/10/2004	10:12:58

doM PRINTS DATE AND TIME

dt. no the date and time are not printed
dt.in.1 the date and time are printed only in the total and not in the single totalisations, using the printer’s internal clock; in the totaliser functioning mode the date and time are printed in the total and not in the single totalisations
dt.in.2 as above, but the date and time are printed in the single totalisations
dt.EX.1 like dt.in.1 but using the clock in the optional date/time board
dt.EX.2 like dt.in.2 but using the clock in the optional date/time board

The date and time is printed, if programmed, before the bar code, which is at the end of the printout.

(!) dt. no

ntik PRINTS TICKET NUMBER

The ticket number is a sequence number which increases upon each printing made, this number, between 1 and 99.999, is kept in memory also when the instrument is turned off and is automatically reset when the value of 99.999 is added.

no	does not print the ticket number	TICKET NR. 3
yES.tot	prints the ticket number only in totalisation	
SuM	prints the ticket number only in the vehicle total	
both	prints ticket number in the totalisation and in the vehicle total	
rESet	by pressing ENTER one clears the progressive ticket number and the "no" mode is automatically set	

(!) no

Note: The ticket number, if programmed, is printed after the weight data.

EndPAG SELECTION OF END PAGE PRINTING

This step allows to select whether to print 2 empty lines at the end of each printout (for attached printer) or, in the case of a labeller, to automatically end the printed label, passing to the next one (vital for the alignment).

no	does not print the end page
yES.tot	prints the end page only in the totalisation
SuM	prints the end page only in the vehicle total
both	prints the end page in the totalisation as well as in the vehicle total

(!) no

Prn.SuM ENABLING THE VEHICLE TOTAL PRINTOUT

This step allows selecting whether to print or not the vehicle total at the end of the totalisation phase.

no	vehicle total printing disabled
yES	vehicle total printing enabled

(!) yES

tErM SETTING TERMINATOR

By connecting a printer it is often necessary to send one of the following characters in order to define the end of the printout line:

Cr	CR (for CUSTOM/DINIALFA COMPATIBLES)
Cr LF	CR LF (for EPSON LX300, TMU295, LP542PLUS, LP542S).

(!) Cr

PForM PRINTOUT FORMATTING

In this step one enters a further selection submenu of the weight data which one wants to print, as well as the print layout and the printing test (see the section "FORMATTING DATA AND LAYOUT").

nr.CoP NUMBER OF TICKET COPIES

Through this step one sets the number of ticket copies which will be printed, valid for any type of printout and functioning mode.

The possible values are 1...3.

(!) 1

7.1 FORMATTING DATA AND LAYOUT

With the ZERO or TARE keys select the parameter which one wants to programme:

To exit press the C key in one of the steps.

dEFaUL PRINTOUT DEFAULT

In this step one enables the instrument's default printouts relative to the totaliser, simple input output and input output totaliser mode.

FiLdS PRINTOUT FIELDS

Once entered this step, the printable weight fields in the totaliser mode, simple input output and input output totaliser are given:

FIELD	DESCRIPTION
PLA. 1	scale 1 current weight
PLA. 2	scale 2 current weight
PLA. 3	scale 3 current weight
PLA. 4	scale 4 current weight
P. 12	sum of scale 1 + 2 weights
P. 13	sum of scale 1 + 3 weights
P. 14	sum of scale 1 + 4 weights
P. 23	sum of scale 2 + 3 weights
P. 24	sum of scale 2 + 4 weights
P. 34	sum of scale 3 + 4 weights
P. 123	sum of scale 1 + 2 + 3 weights
P. 124	sum of scale 1 + 2 + 4 weights
P. 134	sum of scale 1 + 3 + 4 weights
P. 234	sum of scale 2 + 3 + 4 weights
SuM	sum of scale 1 + 2 + 3 + 4 weights
GrA.C.H	x barycentre coordinate
GrA.C.Y	y barycentre coordinate

Table 1

NOTES: 1) It's possible to select only the fields relative to the configured channels.

2) If only channel 1 and channel 2 have been configured, it's possible to print the sum by selecting "SuM" (the "P. 12" field is not displayed).

SELECTION OF THE PRINTABLE FIELDS

1. The instrument displays the first selectable print field.
2. By pressing the ZERO key puts a parameter ("1", "A", "t" or no character) before the field; with this it is possible to select how to print the field (see table 2).

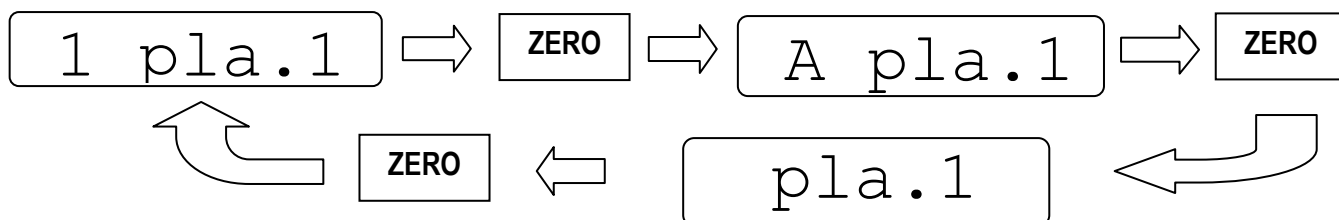

3. Once the selection is made, confirm with PRINT; the instrument goes to the following field (see table 1).
4. Execute the operations from point 5 FOR ALL THE SUGGESTED FIELDS.

!! IMPORTANT !!

If one exits the FiLdS step (by pressing the C key) before having confirmed all the parameters, any changes made are not saved.

5. After confirming the configuration of the last field, the instrument automatically exits the step, storing the changes made.

PARAMETER	FIELD	EXAMPLE OF PRINT RESULT		
no character	PLA 1	FIELD NOT PRINTED		
1		WHEEL 1	300kg	WHEEL 1
A		AXLE 1	300kg	AXLE 1
no character	PLA 2	FIELD NOT PRINTED		
1		WHEEL 2	300kg	WHEEL 2
A		AXLE 2	300kg	AXLE 2
no character	PLA 3	FIELD NOT PRINTED		
1		WHEEL 3	300kg	WHEEL 3
A		AXLE 3	300kg	AXLE 3
no character	PLA 4	FIELD NOT PRINTED		
1		WHEEL 4	300kg	WHEEL 4
A		AXLE 4	300kg	AXLE 4
no character	P. 12	FIELD NOT PRINTED		
1		W1 + W2	600kg	W1 + W2
A		AXLE 5	600kg	AXLE 5
no character	P. 13	FIELD NOT PRINTED		
1		W1 + W3	600kg	W1 + W3
A		AXLE 6	600kg	AXLE 6
no character	P.14	FIELD NOT PRINTED		
1		W1 + W4	600kg	W1 + W4
A		AXLE 7	600kg	AXLE 7
no character	P. 23	FIELD NOT PRINTED		
1		W2 + W3	600kg	W2 + W3
A		AXLE 8	600kg	AXLE 8
no character	P. 24	FIELD NOT PRINTED		
1		W2 + W4	600kg	W2 + W4
A		AXLE 9	600kg	AXLE 9
no character	P. 34	FIELD NOT PRINTED		
1		W3 + W4	600kg	W3 + W4
A		AXLE 10	600kg	AXLE 10
no character	P. 123	FIELD NOT PRINTED		
1		W1 + W2 + W3	900kg	W1 + W2 + W3
A		AXLE 11	900kg	AXLE 11
no character	P. 124	FIELD NOT PRINTED		
1		W1 + W2 + W4	900kg	W1 + W2 + W4
no character	P. 134	FIELD NOT PRINTED		
1		W1 + W3 + W4	900kg	W1 + W3 + W4
no character	P. 234	FIELD NOT PRINTED		
1		W2 + W3 + W4	900kg	W2 + W3 + W4
A		AXLE 12	900kg	AXLE 12
no character	SuM	FIELD NOT PRINTED		
1		TOTAL	1200kg	TOTAL
A		AXLE 13	1200kg	AXLE 11
no character	GrA.C.H	FIELD NOT PRINTED		
1		xg 8m (ALWAYS PRINTS)		xg 8m
t		xg 8m (ONLY IN THE TOTAL)		xg 8m
no character	GrA.C.y	FIELD NOT PRINTED		
1		yg 3m (ALWAYS PRINTS)		yg 3m
t		yg 3m (ONLY IN THE TOTAL)		yg 3m

Table 2

inout.F SPECIFIC PRINT FIELDS FOR THE INPUT/OUTPUT OUTCOME

- **hEAdS** prints headings
hEAdS: the heading is not printed
1hEAdS: the heading is printed
- **ntik** prints ticket number
ntik: the ticket number is not printed
1ntik: the ticket number is printed
- **doM** prints date and time
doM: date and time are not printed
1doM: date and time are printed
- **b.Cod.i** prints the bar code
b.Cod.i: the bar code is not printed
1b.Cod.i: the bar code is printed
(in which the weight is given by | input – output |)

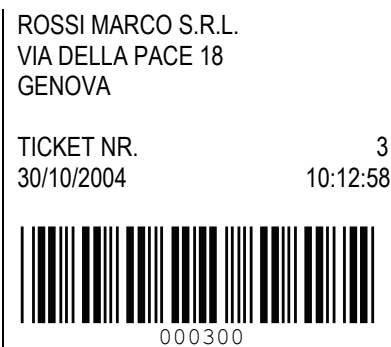

In order to select the fields refer to the description of the preceding step.

The configuration of the bar code is made in the steps subsequent to the **bArC** step.

hEiGt SELECTION OF WEIGHT DATA CHARACTER HEIGHT

h.LoW normal height

h.hiGh double height

(!) **h.LoW**

bArC SETTING OF BAR CODE PRINTOUT

In this step one programmes the printout of the CODE 39 bar code for the TPR attached thermal printer; with the dot matrix printer it isn't possible to print the bar code:

no does not print the bar code

yES.tot prints the bar code only in totalisation

SuM prints the bar code only in the vehicle total

both prints the bar code in totalisation as well as in the vehicle total

The bar code is printed always at the end of the printout (after the date and time).

VdbAr SELECTION OF VERTICAL DISTANCE FROM THE LAST TEXT TO THE BAR CODE (§)

for TPR in lines, in normal font height, programmable field value: 0...9.

(!) **0**

LMbAr LEFT MARGIN SELECTION (§)

for TPR, expressed in 1/8 of a mm (from 0 to 99).

(!) **30**

WbAr SELECTION OF BAR CODE FONT WIDTH (§)

for TPR, programmable value: W1...W3.

(!) **W1**

hbAr SELECTION OF BAR CODE FONT HEIGHT (§)

for TPR, expressed in 1/8 of a mm (from 0 to 255).

(!) **001**

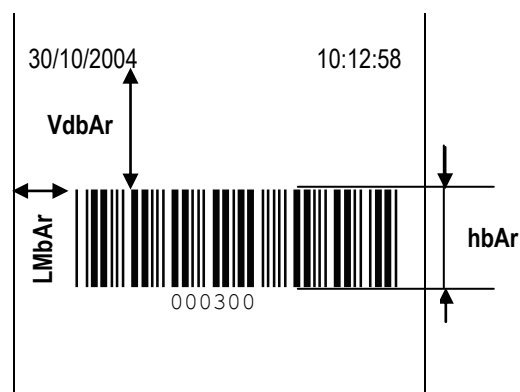

bArFS SELECTION OF BAR CODE PRINT FIELDS (§)

for TPR, programmable value: G; n; t, in which G is the gross weight, n is the net weight and t is the tare weight.

NOTES:

- the weight values are expressed in 6 digits without decimal point and with non significant zeros.
- a space is inserted between a weight value and the following one.
- the bar code is printed as the last data, after the weight values, numeric codes and the ticket number and after the date and time.

(!) G**PntVb PRINTING OF THE BAR CODE FIELD VALUE (§)**

This step allows to select whether to print or not the field value of the print field of the bar code selected in the bArFS step.

- no** the value is not printed
undEr under the bar code
AboVE above the bar code
Ab/un above as well as under the bar code

(!) AboVE

(§) The parameters are displayed only if "yES" has been selected in the **SEtuP >> SEriAL >> CoM.Prn >> Pr.ConF >> PForM >> bArC** step or "1" in the **SEtuP >> SEriAL >> CoM.Prn >> Pr.ConF >> PForM >> inout.F >> b.Cod.i** step.

PtEst PRINTOUT TEST

This step allows to carry out a print test, in other words to print the configured fields, in order to quickly make corrections. Actually the indicator remains inside the menu even after printing.

By entering the step, a list of test printouts appear:

- rESEt: resetting the totalizers
tot: totalisation test
SuM: prints vehicle total
SuM.t: prints vehicle total with stored tare total
tot.in: input weight totalisation
SuM.in: input weight total
tot.out: output weight totalisation
SuM.out: output weight total
Prn.kEy prints simple weigh
SuM.VEH: number of vehicles and relative total

The data printed in the PtEst depends on the formatting of the printouts.

IMPORTANT: by entering the PtEst step one resets the scale totals.

When exiting the quick formatting menu of the printouts, if changes have been made, "SAVE?" appears; press ENTER to confirm the changes made, and C to exit without saving.

!! IMPORTANT !!

The printout configuration automatically changes depending on the active visualisation when printing; for example, if one configures the printout for four scales, but at the moment of the printout the displayed weights is the one relative to two scales, just the weight data set for those two scales will be printed.

8. PRINTING THE HEADING

It is possible to programme from the indicator or from PC, 4 alphanumeric lines of heading with 24 characters each, which will be printed in the programmed mode (until these are cancelled or substituted).

PROGRAMMING THE HEADING

Enter in the TECHNICAL SET-UP >> **SEtuP** >> **SEriAL** step.

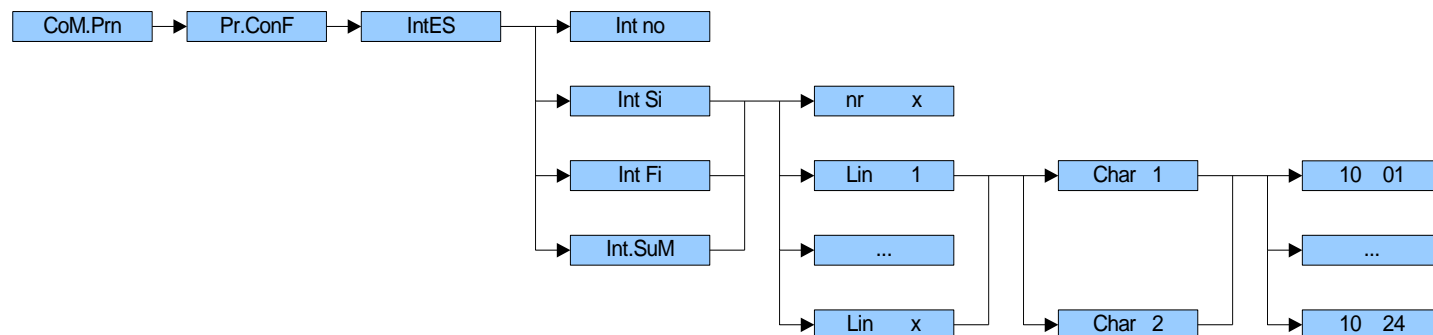

1. Enter in the **CoM.Prn** step.
2. Enter in the **Pr.ConF** step.
3. Enter in the **IntES** step.
4. Select the print mode of the heading:
 - Int no** = does not print the heading
 - Int Si** = prints the heading only with the first totalisation
 - Int Fi** = prints the heading in all the totalisations
 - Int.SuM** = prints the heading only in the sum
5. Select a mode other than **Int no**; one is asked to enter the number of heading lines; the display shows **nr x** in which x is the number of set lines (from 0 to 4).
6. Select the number of lines, using the ZERO key and press ENTER to confirm.
7. For a few seconds, **Lin 1** appears on the display in order to show which line one is programming (in this case line 1).
8. Then the instrument asks to select the print character height:
 - ChAr 1** = prints line at a standard height
 - ChAr 2** = prints line at double the height
 Use the ZERO key to select the character height, then press ENTER to confirm.
9. One can now programme the first line of the heading; in other words one enters a sequence of two - digit numerical codes, corresponding to the characters (see **Table 3**). A line can have up to 24 characters (including the empty spaces).

LIST OF THE CODES AND THEIR CORRESPONDING PRINTED CHARACTERS

CODE	CHARACTER	CODE	CHARACTER	CODE	CHARACTER
32		66	B	100	d
33	!	67	C	101	e
34	"	68	D	102	f
35	#	69	E	103	g
36	\$	70	F	104	h
37	%	71	G	105	i
38	&	72	H	106	j
39	'	73	I	107	k
40	(74	J	108	l
41)	75	K	109	m
42	*	76	L	110	n
43	+	77	M	111	o
44	,	78	N	112	p
45	-	79	O	113	q
46	.	80	P	114	r
47	/	81	Q	115	s
48	0	82	R	116	t
49	1	83	S	117	u
50	2	84	T	118	v
51	3	85	U	119	w
52	4	86	V	120	x
53	5	87	W	121	y
54	6	88	X	122	z
55	7	89	Y	123	{
56	8	90	Z	124	
57	9	91	[125	}
58	:	92	\	126	~
59	;	93]	127	△
60	<	94	^		
61	=	95	_		
62	>	96	`		
63	?	97	a		
64	@	98	b		
65	A	99	c		

Table 3

NOTE: the characters from 128 to 255 depend on the printer.

In the entry phase, the display is managed in the following way:

01 032 on the left one enters the character (32 is the default character), while the number on the right shows the position of this character in the line.

To modify the character, press ENTER/PRINT and then use ZERO and TARE keys or the numerical keyboard in order to enter the values of the digits. By pressing MODE one can select the next digit.

For example:

To write "ROSSI GIUSEPPE S.R.L.", one should set the following codes:

82 / 79 / 83 / 83 / 73 / 32 / 71 / 73 / 85 / 83 / 69 / 80 / 80 / 69 / 32 / 83 / 46 / 82 / 46 / 76 / 46 / 32 / 32 / 32

10. When the programming of a heading line is done, the instrument automatically passes on to the next line
11. Repeat the operations from point 7 for all the set lines.
12. When the programming of the heading is done, the instrument automatically passes on to the following step
nuMWEi.
13. Press the C key until the instrument shows the step "SAvE?": press ENTER to save the changes made.

When displaying the code and position, these are the available functions:

TARE: cursor forwards: while one is programming a print line, it allows to scroll the set characters and modify them.

ZERO: cursor backwards: while one is programming a print line, it allows to scroll the set characters and modify them.

C: once the programming or the modification of a print line has been made, by carrying out this function **the new programming is memorised.**

F: function menu: a menu in which three functions appear
“ **HELP** ”: summarizes the codes of the alphanumeric codes and the list of the other functions.

“**DEL.LIN**”: while one is programming a print line, it carries out this command; **all the codes of this line are cancelled.**

“**PRINT.L**”: while one is programming a print line, by carrying out this command, **the test printing of the line is carried out.**

9. ANALOGUE OUTPUT (OPTIONAL)

It is possible to use an analogue output configurable at 0 – 10V, 0 – 20 mA or 4 – 20 mA.

The voltage and the output current from the interface are proportional to the weight displayed or to the sum of the weights on the connected scales.

In regards to the electrical connection scheme, refer to the section “CONNECTION SCHEMES”.

Note: The analogue output is updated every 20ms and takes on the value corresponding to the weight converted in that instant; therefore, if the filter is slowed on the weight also the analogue output is slowed.

ANALOGUE OUTPUT PROPORTIONAL TO DISPLAYED WEIGHT

The voltage or the current is proportional to the displayed weight; therefore it varies depending on the displayed data.

Even the underload and overload conditions depend on the displayed data:

If the sum of weights is displayed, the analogue output supplies the minimum set value when the weight of one or more scales rises over the maximum capacity + 9d, or decreases below the 0 of 100d.

If a single scale is displayed, the analogue output supplies the minimum value when the weight on the scale rises over the maximum capacity + 9d, or decreases below the 0 of 100d.

The weights on the other scales are not taken into consideration.

ANALOGUE OUTPUT PROPORTIONAL TO THE SUM OF WEIGHTS

The voltage or the current is proportional to the sum of weights on the connected scales.

The underload and overload conditions depend on the sum of the weights:

Whether the sum of weights or the weight on the single scale is displayed, the analogue output supplies the minimum set value when the weight of one or more scales rises over the maximum capacity + 9d, or decreases below the 0 of 20d.

The weights of all the scales are taken into consideration.

For configuring the parameters, one should enter in the set-up environment, in the **SEtUP >> ConFIG >> An.out** step; one will then enter a submenu made up of the following steps:

ModE: TYPE OF ANALOGUE OUTPUT

Ao no = analogue output disabled

Ao ViS = analogue output on displayed weight

Ao SuM = analogue output on the sum of weights on all the connected scales

Once the functioning mode is confirmed, one sets the values of the analogue output, in other words one enters the values of the digital / analogue converter (between 0 and 65535) to which a certain voltage or current output value corresponds to.

In this configuration the instrument keys take on the following meanings (functions):

ZERO It decreases the selected digit (blinking).

TARE It increases the selected digit (blinking)

MODE It selects the digit to be modified (blinking) from left to right.

ENTER By pressing once after have a value has been entered, it enables the corresponding output analogue value, (allowing the check) but remains still inside the step in case of a new modification. By pressing a second time (on the same entered value), it confirms and exits the step.

C It allows to quickly zero the present value.

NUMERIC KEYS These allow to enter values, from right to left.

WGT.1, WGT.2, WGT.3

By entering these steps, one sets the weight value linked to the relative point of the analog output; in other words if the weight read reaches these points, there will be the corresponding value on the analog output. This value can be between -99999 and 999999.

NOTES: if one wants these steps work well, one must set $WGT.1 < WGT.2 < WGT.3$. If $WGT.1 \geq WGT.2$, the analog output can't have a valid value. If $WGT.1 < WGT.2$ and $WGT.2 \geq WGT.3$, the point corresponding to $WGT.3$ won't be taken into consideration. The analog value output of the present weight will be calculated by the interval which contains it.

PNT.1, PNT.2, PNT.3

By entering these steps, one sets the analogue output value when the scale displays the corresponding weight point value

(which is set by last step). This value can be anywhere between 0 and 65535 (values of the digital/analogue converter); if a higher value is entered, the instrument emits a prolonged sound and then it zeros the parameter.

PNT.UND

By entering this step, one sets the value of the analogue output when the weight is smaller than WGT.1. This value can be anywhere between 0 and 65535 (values of the digital/analogue converter); if a higher value is entered, the instrument emits a prolonged sound and then it zeros the parameter.

PNT.OVR

By entering this step, one sets the value of the analogue output when the weight is larger than the maximum weight point value. This value can be anywhere between 0 and 65535 (values of the digital/analogue converter); if a higher value is entered, the instrument emits a prolonged sound and then it zeros the parameter.

APPROXIMATE VALUES BETWEEN THE D/A CONVERTER AND ANALOGUE OUTPUT

D/A CONVERTER VALUES	VOLTAGE VALUE (V)	CURRENT VALUE (Ma)
1200	0	0
11250		4
52200		20
62300	10	

GRAPH:

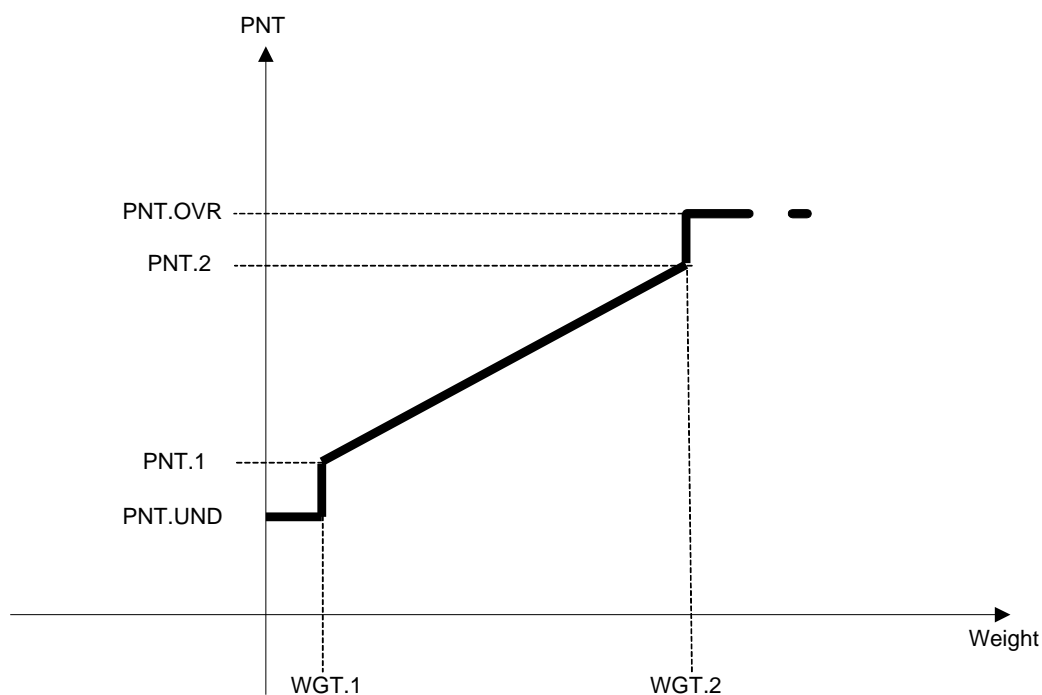

10. ENERGY SAVING

If the scale is powered by battery, it is possible to set the following parameters in the setup (see the paragraph "DESCRIPTION OF THE STEPS") in order to increase the battery life:

- **Backlighting functioning**
See **F.ModE** >> **En.SAVE** >> **LAMP**
- **Display intensity**
See **F.ModE** >> **En.SAVE** >> **L.int**
- **Auto Switch-Off**
See **F.ModE** >> **En.SAVE** >> **AutoFF**
- **Radio module energy saving**
See **F.ModE** >> **En.SAVE** >> **rAdio**
- **Weight updating**
See **F.ModE** >> **En.SAVE** >> **En.ModE**

11. CONFIGURATION OF DFWKRPRF CONNECTED TO WWSERF PLATFORMS

For the correct functioning of a system consisting of a DFWKRPRF connected to the WWSERF platforms one has to set the following parameters (example with four platforms):

	DFWKRPRF	WWSERF n.1	WWSERF n.2	WWSERF n.3	WWSERF n.4
t.PoWEr	Not visible	on	on	on	on
Stabil.	r.AdC 1	default	default	default	default
rAdio	CoM1, Ch. X	CoM2, Ch. X	CoM2, Ch. X	CoM2, Ch. X	CoM2, Ch. X
En.ModE	MAX	MAX	MAX	MAX	MAX
PC.SEL	CoM1	CoM2	CoM2	CoM2	CoM2
PCModE	r.AdC, Ad485 = 05, Add.oFF = 00	485, Ad485 01	485, Ad485 02	485, Ad485 03	485, Ad485 04
ALiM	Not visible	6 Vr	6 Vr	6 Vr	6 Vr

12. CONFIGURATION OF DFWKRPRF AS REPEATER

It is possible to add one or more DFWKRPRF instruments to repeat the weight data provided from a system consisting of one or more WWSERF platforms connected to a DFWKRPRF transmitter.

This type of repeater can be configured to repeat the weight of all the platforms connected to the DFWKRPRF transmitter: in this case one has to execute the following procedure:

- 1) enter in the **SEtuP** >> **SEriAL** >> **CoM.PC** >> **PCModE** >> **r.AdC** step and set the "Ad485" parameter on the value 99, then confirm the value 00 in the "Add.oFF" parameter;
- 2) turn off the DFWKRPRF transmitter;
- 3) enter in the **SEtuP** >> **ConFiG** >> **nChAn** step, select the number of channels and press ENTER/PRINT: the display shows the "r.CFG?" message; by pressing ENTER/PRINT the instrument receives the calibration data from the platforms. Then press the C key more times until the display shows "SAVE?" and press ENTER/PRINT to confirm.

It is also possible to receive the weight provided from a lower number of platforms: it can be useful when one wants to receive only the weight of a couple of wheels (for example only the third and fourth one).

In the case of this example, one has to follow the previous procedure, with these differences: the value 02 has to be set in the "Add.oFF" parameter (with this offset the repeater can receive the data from the platforms 3 and 4, and the parameter "Ch 2" has to be set in the **SEtuP** >> **ConFiG** >> **nChAn** step.

13. CONFIGURATION OF THE SYSTEM DFWKRPRF– DFWLAPKR

It is possible to create a wireless weighing station by connecting one or more DFWLAPKR indicators to the DFWKRPRF instrument. In this type of systems, the DFWLAPKR indicators have to be fitted with the DFWKR type firmware, the DFWKRPRF instrument has to be fitted with the MASTER type firmware.

In the following tables are shown the examples of configuration of the system with one or two DFWLAPKR indicators:

	DFWKRPRF	DFWLAPKR
FunCt	MAStR, nuMSL= 01, LiStEn= no, Print= yES, ProtoC= ExtEnd, t.kEyB= kb.dFkr, WGH.LSt=no	Not visible
t.PoWEr	Not visible	on
rAdio	CoM1, Ch. X	CoM2, Ch. X
En.ModE	MEdiuM	MEdiuM
PC.SEL	CoM1	CoM2
PCModE	485, Ad485 00	485, Ad485 01
Pr.ModE	tPr	tPr
ALiM	Not visible	6 Vr

	DFWKRPRF	DFWLAPKR n.1	DFWLAPKR n.2
FunCt	MAStR, nuMSL= 02, LiStEn= no, Print= yES, ProtoC= ExtEnd, t.kEyB= kb.dFkr, WGH.LSt=no, SuM.PAr *	Not visible	Not visible
t.PoWEr	Not visible	on	on
rAdio	CoM1, Ch. X	CoM2, Ch. X	CoM2, Ch X
En.ModE	MEdiuM	MEdiuM	MEdiuM
PC.SEL	CoM1	CoM2	CoM2
PCModE	485, Ad485 00	485, Ad485 01	485, Ad485 02
Pr.ModE	tPr	tPr	tPr
ALiM	Not visible	6 Vr	6 Vr

* In the SuM.PAr menu one has to set the parameters of the sum of weights displayed: SuM.dEC (number of decimals), SuM.diV (division), SuM.MAX (maximum value), SuM.uM (unit of measure).

The following diagram shows the menu that contains the steps of the MASTER type firmware that has to be set:

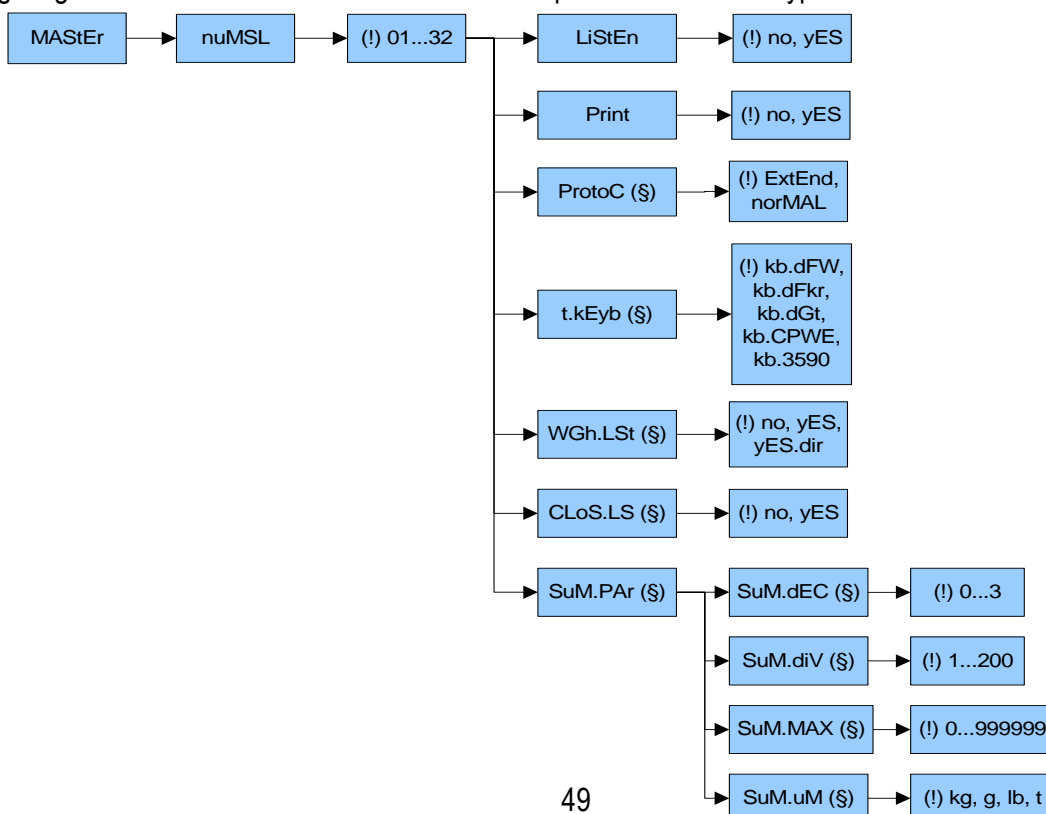

14. CONNECTION SCHEMES

14.1 DFWKRP, DFWKRPRF MOTHERBOARD

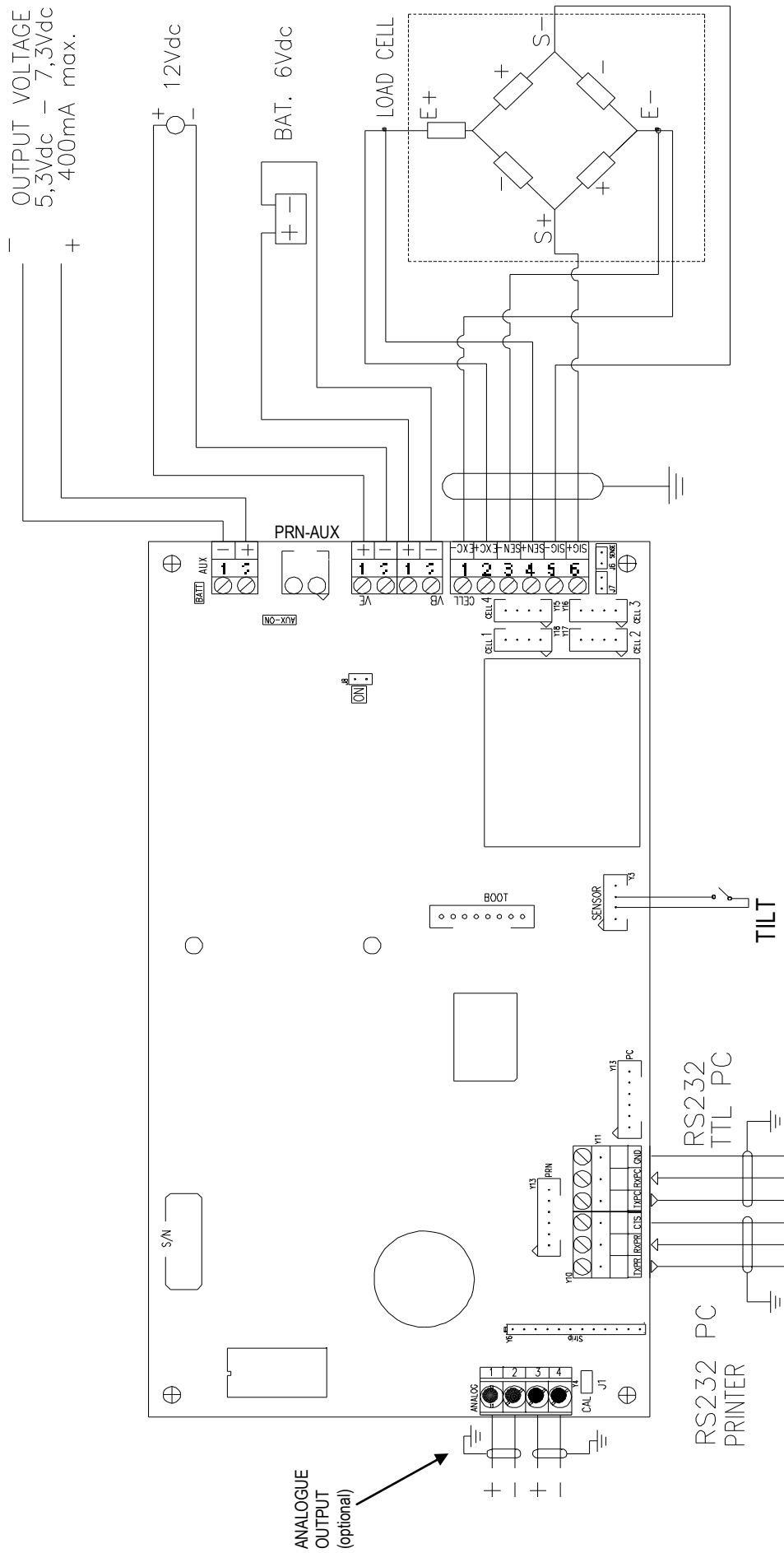

ANALOGUE OUTPUT (optional)

MEANING OF MOTHER BOARD TERMINAL BOARDS AND JUMPERS

VB 6 Vdc BATTERY POWER SUPPLY

- 2 - BATT – (0 Vdc) GND
- 1 + BATT + (6 Vdc)

VE 12 Vdc POWER SUPPLY

- 2 - 0 Vdc (GND)
- 1 + +12 Vdc

AUX and PRN-AUX: AUXILIARY POWER SUPPLY

- 1 - 0 Vdc (GND)
- 2 + 5,3 –7,3 Vdc 400 mA max

It is used to power an external device and its functioning mode depends on the "PWr.Prn" parameter of the set-up environment;

Pr-no with instrument on, printer not managed and auxiliary output always active.

PWr.EXt with instrument on, printer managed and auxiliary output always active.

PWr.int printer managed, auxiliary output active only when the instrument prints.

Ext.oFF printer managed and auxiliary output always active; the start-up characters are transmitted to the printer, because the printer is considered to be configured in energy saving mode.

AUX-ON = if closed, the auxiliary output is always active independently from the "PWr.Prn" parameter of the set-up environment.

BATT = if closed, it enables the indication of the battery level; see the section "BATTERY LEVEL WARNING" (**USER MAN.REF.**).

CELL LOAD RECEPTOR

- 1 EXC - POWER SUPPLY -
- 2 EXC + POWER SUPPLY +
- 3 SENS - REFERENCE -
- 4 SENS + REFERENCE +
- 5 SIG - SIGNAL -
- 6 SIG + SIGNAL +

CELL1, CELL2, CELL3, CELL4

- 1 EXC + POWER SUPPLY +
- 2 EXC - POWER SUPPLY -
- 3 SIG + SIGNAL +
- 4 SIG - SIGNAL -

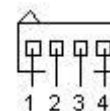

J6 and **J7** = if closed, REFERENCE + and POWER SUPPLY +, REFERENCE – and POWER SUPPLY – are jumpered on the board.

J1 = if closed, it enables the access to the metrological parameters.

J8 ON = if closed it enables the automatic start-up of the indicator as soon as power is supplied.

NOTE: If the **BATT** jumper is closed and the battery is being charged, the function is disabled.

BOOT = connector for the connection of the first I/O expansion board, the "Real time clock" board.

ANALOGUE OUTPUT (optional)

- 1 + 20 mA
- 2 0 mA
- 3 + 10 V
- 4 0 V

Note: the maximum resistance applicable on the output current is 350 Ohm and the minimum resistance applicable on the output voltage is 10 kohm.

PC SERIAL PORT

- 4 TX2 TX
- 5 RX2 RX
- 6 GND GND

PC JUMPERS

- 1 and 2 all closed = RS232 serial output
- 2 and 3 all closed = TTL serial output

PNR SERIAL PORT

1 TX0 TX
 3 CTS CTS
 6 GND GND

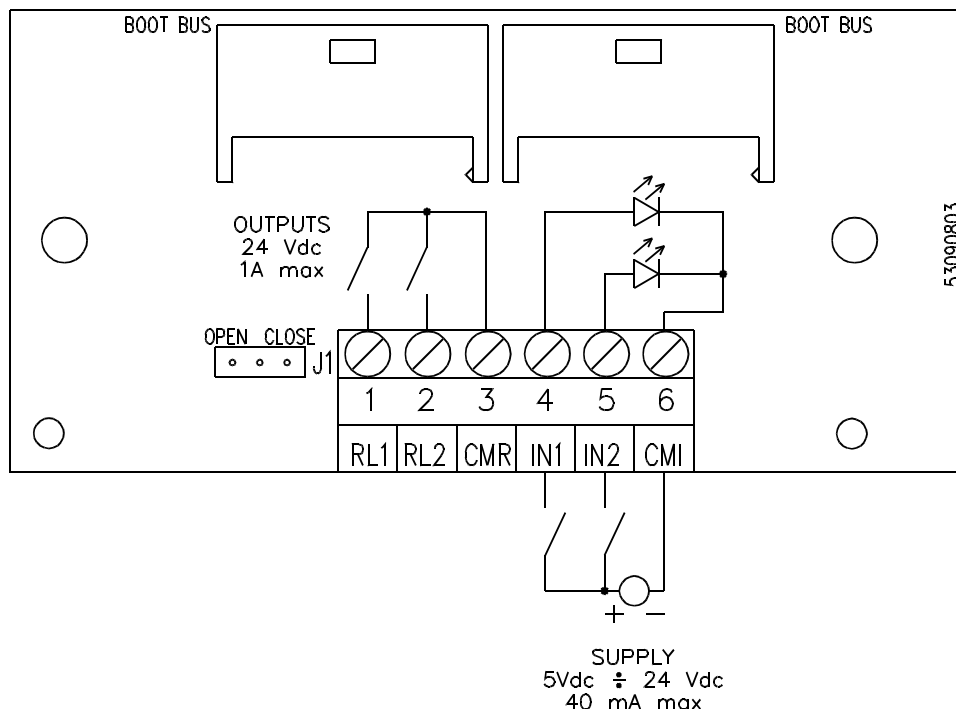
14.1.1 I/O OPTIONAL EXPANSION CARD WITH 2 INPUTS AND 2 OUTPUTS

It is possible to connect two expansion cards having 2 inputs and 2 relay outputs each. The first I/O board is connected through a 350 mm cable which connects the IO/BOOT connector (on the indicator board) and the BOOT BUS connector (on the I/O board); the second board instead is connected "in cascade" to the first one with a 350 mm cable (equal to the previous one) which connects the two BOOT BUS connectors. Since the two BOOT BUS connectors are connected in parallel, it does not matter which one is used in the connections.

With the jumper J1 in two positions (OPEN and CLOSE) one selects whether the board should manage inputs 1 and 2 and relays 1 and 2 (J1 in OPEN position) or whether it should manage inputs 3 and 4 and relays 3 and 4 (J1 in CLOSE position). Therefore the correct configuration with two cascade boards is:

BOARD 1 J1 on OPEN (therefore Input 1, Input 2, Relay 1, Relay 2)
 BOARD 2 J1 on CLOSE (therefore Input 3, Input 4, Relay 3, Relay 4)

J1 Management of Inputs and Relays

OPEN IN1, IN2, RL1, RL2
 CLOSE IN3, IN4, RL3, RL4

The inputs will be put outside the instrument with a 12 X 0,5 mm multipolar cable connected in this way:

MEANING	COLOUR
RL1	WHITE
RL2	GREY
CMR (common relay)	BLACK
IN1	RED
IN2	BLUE
CMI (common input)	BROWN
+ VE (+12 Vdc)	WHITE - GREEN
- VE (GND)	WHITE - BROWN

ONLY WITH SECOND CONNECTED I/O CARD:

RL3	PINK
RL4	GREEN
IN3	YELLOW
IN4	PURPLE

The maximum power of the relays is 24 Vdc 1A, the maximum voltage applicable to the optoisolated inputs is between 5 – 24 Vdc with maximum current of 40 mA.

The optoisolation of the inputs is not correct any more if these are activated with a voltage available on the indicator (for example the battery voltage VB), an external voltage must be used instead; however, for convenience the VB of the indicator (battery voltage) is brought onto the multipolar cable.

!!!WARNING!!!

Be careful not to short-circuit the wires of the VB (WHITE – BROWN and WHITE – GREEN wires) since this would cause permanent damages to the electronic card.

14.1.2 RS 485 OPTIONAL SERIAL

PC SERIAL PORT

A(+)	Line 485 +
B(-)	Line 485 -

On the same RS 485 line it's possible to connect up to 32 indicators.

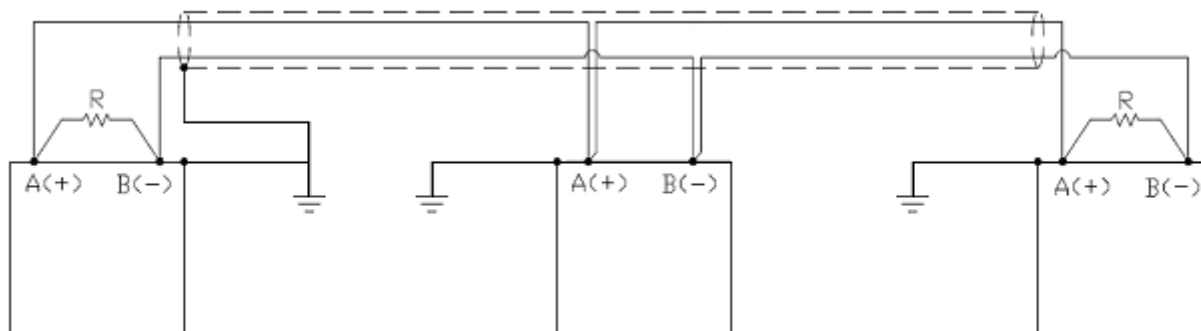
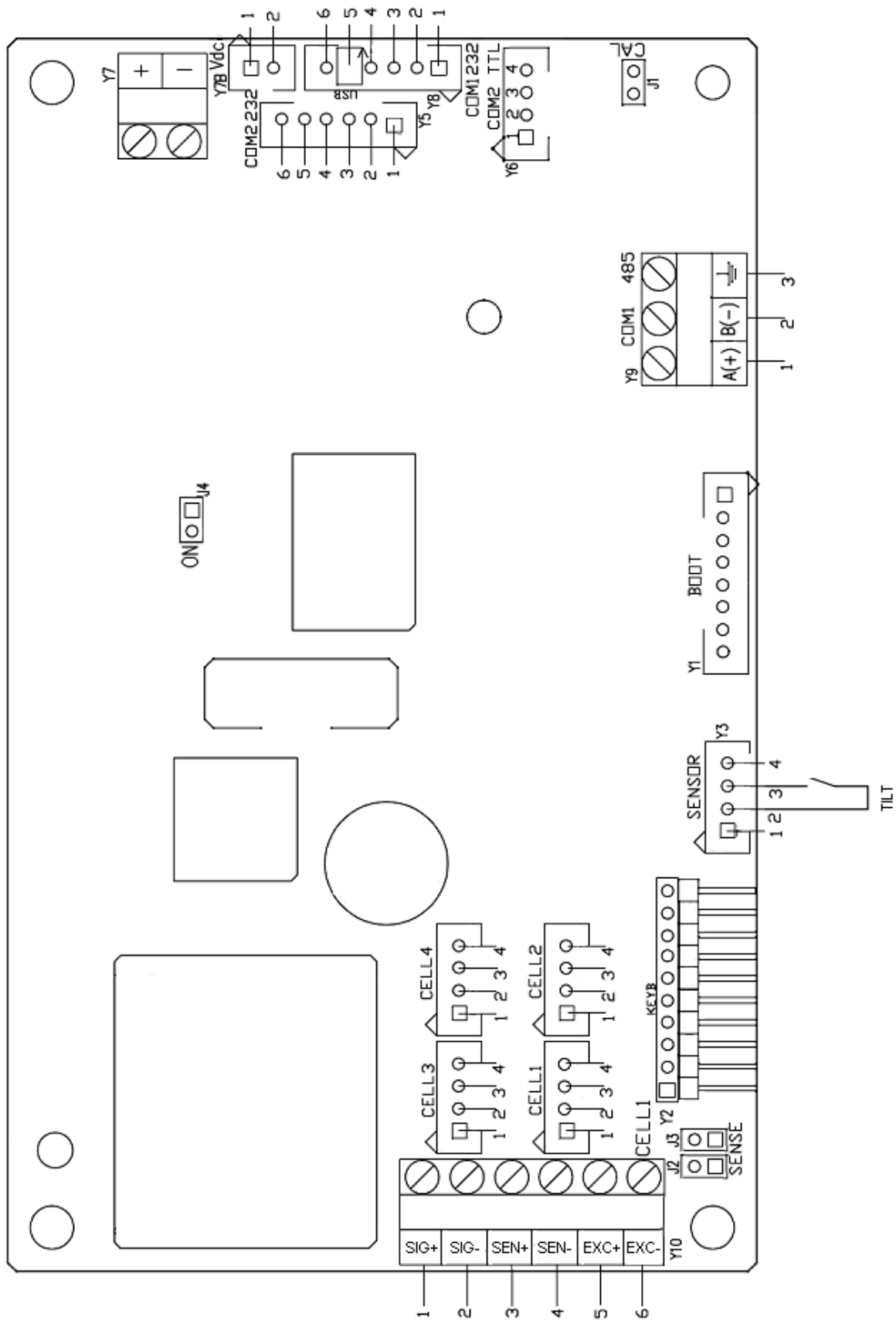

Figure 1: electrical diagram of the connections and the 2 termination resistances.

On the RS485 network normally one connects 2 termination resistances of 120 ohm (shown with "R" in figure 1), **ONLY** on the 2 devices **which are at the 2 ends of the cable**.

The maximum reachable length from the line with the use of the appropriate cable for RS 485 connections, the twisted 2x24 AWG duplex cable, shielded with external sheathing + aluminium band, is of about 1200 meters.

14.2 DFWLAPKR



MEANING OF MOTHER BOARD TERMINAL BOARDS AND JUMPERS**Vdc POWER SUPPLY Y7**

1 + 4,8 - 12 Vdc +12 Vdc
 2 - 0 Vdc (GND)

Vdc POWER SUPPLY Y7B

1 4,8 - 12 Vdc +12 Vdc
 2 0 Vdc (GND)

J4 ON = if closed it enables the automatic start-up of the indicator as soon as power is supplied.

LOAD RECEPTOR**CELL1**

1 **SIG +** SIGNAL +
 2 **SIG -** SIGNAL -
 3 **SEN +** REFERENCE +
 4 **SEN -** REFERENCE -
 5 **EXC +** POWER SUPPLY +
 6 **EXC -** POWER SUPPLY -

CELL1, CELL2, CELL3, CELL4

1 **EXC +** POWER SUPPLY +
 2 **EXC -** POWER SUPPLY -
 3 **SIG +** SIGNAL +
 4 **SIG -** SIGNAL -

J2 and **J3** = if closed, REFERENCE + and POWER SUPPLY +, REFERENCE – and POWER SUPPLY –are jumpered on the board

J1 CAL= if closed, it enables the access to the metrological parameters.

BOOT = connector for the connection of the first I/O expansion board or for the ALIBI MEMORY board.

COM1 232

1 TX
 2 RX

 4 +5V
 5 Vin USB
 6 GND

COM2 232

1 TX
 2 RX
 3 CTS
 4 +5V
 6 GND

COM1 485

1 **A(+)** Line 485 +
 2 **B(-)** Line 485 -
 3 \perp Earth

COM2 TTL

1 +5V
 2 GND
 3 TX-TTL
 4 RX-TTL

14.3 LOAD CELL CONNECTOR CIRCUIT DIAGRAM

7 PIN FEMALE CONNECTOR

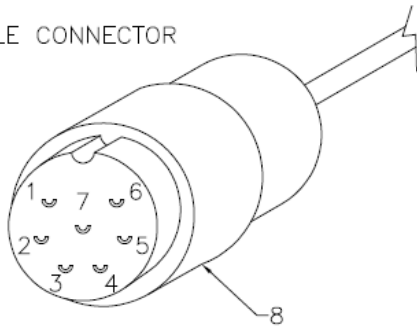

- 1 INPUT +
- 2 INPUT -
- 3 SENS -
- 4 SENS +
- 5 OUTPUT -
- 6 OUTPUT +
- 7 not connected
- 8 SHIELD TO BE FOLDED AND PLACED UNDER THE CONNECTOR CABLE TIGHTENER