

IQ plus® 390-DC

Digital Weight Indicator

Version 1.0

Installation Manual



RICE LAKE WEIGHING SYSTEMS
Industrial Solutions on a Global Scale®



Contents

About This Manual	1
1.0 Introduction.....	1
1.1 Operating Modes.....	1
1.2 Front Panel Keypad	2
1.3 Display Annunciators	2
1.4 Indicator Operations	3
1.4.1 Toggle Gross/Net/Piece Count Mode	3
1.4.2 Toggle Units.....	3
1.4.3 Zero Scale	3
1.4.4 Acquire Tare	3
1.4.5 Remove Stored Tare Value	3
1.4.6 Print Ticket.....	3
1.4.7 Acquire Parts Sample	3
2.0 Installation.....	4
2.1 Unpacking and Assembly	4
2.2 Enclosure Disassembly.....	4
2.3 Cable Connections	4
2.3.1 Load Cells.....	5
2.3.2 Serial Communications	5
2.4 Enclosure Reassembly.....	6
2.5 Battery Installation	6
2.6 AC Adapter	6
2.7 Board Removal.....	6
2.8 Replacement Parts	7
3.0 Configuration.....	9
3.1 Configuration Methods	9
3.1.1 Revolution Scaleware Configuration	9
3.1.2 EDP Command Configuration	9
3.1.3 Front Panel Configuration.....	10
3.2 Menu Structures and Parameter Descriptions.....	11
3.2.1 Configuration Menu.....	12
3.2.2 Format Menu	14
3.2.3 Calibration Menu	16
3.2.4 Serial Menu.....	17
3.2.5 Program Menu.....	18
3.2.6 Print Format Menu	20
3.2.7 Version Menu.....	20
4.0 Calibration.....	21
4.1 Front Panel Calibration.....	21
4.2 EDP Command Calibration.....	22
4.3 Revolution™ Scaleware Calibration	22
5.0 EDP Commands.....	23
5.1 The EDP Command Set	23
5.1.1 Key Press Commands	23
5.1.2 Reporting Commands.....	24
5.1.3 The RESETCONFIGURATION Command.....	24
5.1.4 Parameter Setting Commands.....	24
5.1.5 Normal Mode Commands.....	26

5.2	Saving and Transferring Data	26
5.2.1	Saving Indicator Data to a Personal Computer	26
5.2.2	Downloading Configuration Data from PC to Indicator.....	26
6.0	Counting Operations.....	27
7.0	Print Formatting	28
7.1	Print Formatting Commands.....	28
7.2	Customizing Print Formats.....	28
7.2.1	Using the EDP Port	28
7.2.2	Using the Front Panel.....	29
7.2.3	Using Revolution Scaleware	30
8.0	Appendix	31
8.1	Error Messages	31
8.2	Continuous Output (Stream) Format	31
8.3	ASCII Character Chart	32
8.4	Front Panel Display Characters.....	34
8.5	Conversion Factors for Secondary Units	35
8.6	Digital Filtering	36
8.6.1	DIGFLx Parameters.....	36
8.6.2	DFSENS and DFTHRH Parameters.....	36
8.6.3	Setting the Digital Filter Parameters.....	37
8.7	Test Mode	37
8.8	Specifications	39
	IQ plus 390-DC Limited Warranty.....	40

About This Manual

This manual is intended for use by service technicians responsible for installing and servicing IQ plus® 390-DC digital weight indicators.

Configuration and calibration of the indicator can be accomplished using the indicator front panel keys, the EDP command set, or the Revolution Scaleware™ configuration utility. See Section 3.1 on page 9 for information about configuration methods.



Warning

Some procedures described in this manual require work inside the indicator enclosure. These procedures are to be performed by qualified service personnel only.



Authorized distributors and their employees can view or download this manual from the Rice Lake Weighing Systems distributor site at www.rlws.com.

The *Operator Card* included with this manual provides basic operating instructions for users of the IQ plus 390-DC. Please leave the *Operator Card* with the indicator when installation and configuration are complete.

1.0 Introduction

The IQ plus 390-DC is a single-channel digital weight indicator housed in a NEMA 4X/IP66-rated stainless steel enclosure. The indicator front panel consists of a 1 in (25 mm), six-digit, liquid crystal (LCD) display and six-button keypad. Features include:

- Drives up to four 350Ω or eight 700Ω load cells
- Supports 4- and 6-wire load cell connections
- Electronic data processing (EDP) port for full duplex, RS-232 communications at up to 19200 bps
- Powered by 6 C batteries for complete portability
- AC adapter for 115 or 230 VAC power
- Configurable standby mode limits indicator power consumption when scale is inactive
- Piece count mode for basic parts counting functions.

The IQ plus 390-DC is NTEP-certified for Classes III and III L at 10,000 divisions. See Section 8.8 on page 39 for detailed specifications.

1.1 Operating Modes

The IQ plus 390-DC has several modes of operation:

Normal (weighing) mode

Normal mode is the “production” mode of the indicator. The indicator displays gross or net weights as required, using the LCD annunciators described in Section 1.3 on page 2 to indicate scale status and the type of weight value displayed. Once configuration is complete and a legal seal is affixed to the back of the indicator, the IQ plus 390-DC can operate only in normal mode.

Piece count mode

In piece count mode, the indicator display shows the number of parts on the scale rather than the weight of those parts. Piece count mode has two submodes:

- Count display mode displays the current parts count and allows ticket printing using the CFMT print format.
- Sample acquisition mode is used to calibrate the indicator for parts counting.

Operator access to piece count mode is disabled when the indicator is shipped from the factory. See Section 6.0 on page 27 for detailed information about counting operations.

Setup mode

Most of the procedures described in this manual require the indicator to be in setup mode, including configuration and calibration.

To enter setup mode, remove the large fillister head screw from the enclosure backplate. Insert a screwdriver or a similar tool into the access hole and press the setup switch once. The indicator display changes to show the word *CONFIG*.

Test mode

Test mode provides a number of diagnostic functions for the IQ plus 390-DC indicator. Like setup mode, test mode is entered using the setup switch. See Section 8.7 on page 37 for more information about entering and using test mode.

Standby mode

Standby mode is a configurable low-power mode used to extend battery life when the indicator is inactive. In standby mode, the LCD display shows the word *STNDBY*; press any key to exit standby mode. See Section 3.2.5 on page 18 for information about configuring standby mode.

1.2 Front Panel Keypad

Figure 1-1 shows the IQ plus 390-DC front panel keys and the key functions assigned in normal mode.

The symbols shown above the keys in Figure 1-1 (representing up, down, enter, left, right) describe the key functions assigned in setup mode. In setup mode, the keys are used to navigate through menus, select digits within numeric values, and increment/decrement values. See Section 3.1.3 on page 10 for information about using the front panel keys in setup mode.

Labels under the keys in Figure 1-1 describe the key functions used in piece count mode. See Section 6.0 on page 27 for more information about counting operations.

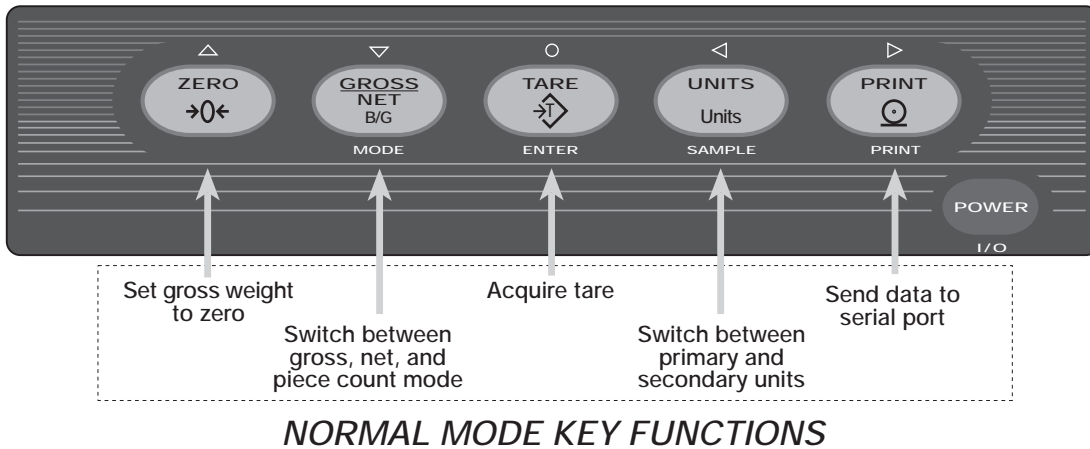

Figure 1-1. Front Panel Key Functions in Normal Mode

1.3 Display Annunciators

The IQ plus 390-DC display uses a set of LCD annunciators to provide additional information about the value being displayed. Figure 1-2 on page 3 shows these annunciators and their meanings.

G The displayed weight is a gross weight.

N The displayed weight is a net weight.



Scale is at standstill or within the specified motion band. Some operations, including zero, tare, and printing functions, can only be done when the standstill symbol is shown.



Center of zero. Gross weight is within 0.25 graduations of zero. This annunciator lights when the scale is zeroed.



Indicates that a tare has been entered. The tare value can be entered by pressing the TARE key on the keypad or by sending the KTARE EDP command. See Section 5.0 on page 23 for information about the EDP command set.



Indicates that the battery charge is low.

lb, kg, PC

Three arrow annunciators on the right side of the LCD display indicate the units associated with the displayed value. The bottom arrow annunciator (PC) is lit when the indicator is in piece count mode. The top and middle arrows, labeled lb and kg, show primary and secondary units, as described below:

- If the displayed weight is in pounds, the top arrow (lb) is lit; if kilograms, the middle arrow (kg) is lit.
- If the primary unit of weight is pounds, the middle (kg) arrow is lit for secondary units—or, if the primary unit is kilograms, the top (lb) arrow is lit for secondary units, unless the secondary unit of weight is the same as the primary unit.
- If neither primary nor secondary units are pounds or kilograms, the top arrow is used as a primary units annunciator and the middle arrow is used as the secondary units annunciator. A set of replacement overlay decals is included in the parts kit for units other than pounds and kilograms.

See Section 3.2.2 on page 14 for information about configuring primary and secondary display units.

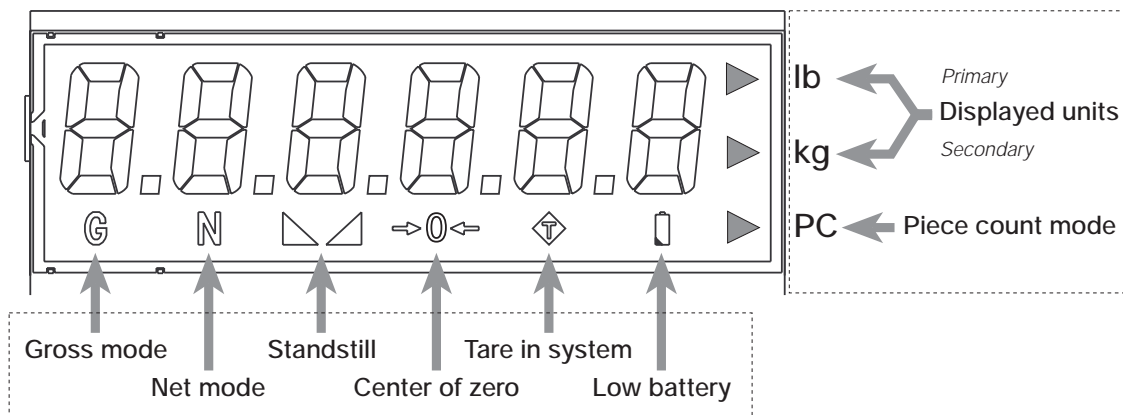

Figure 1-2. IQ plus 390-DC Display Annunciators

1.4 Indicator Operations

Basic IQ plus 390-DC operations are summarized below:

1.4.1 Toggle Gross/Net/Piece Count Mode

Press the GROSS/NET key to switch the display mode between gross, net, and piece count modes. If a tare value has been entered or acquired, the net value is the gross weight minus the tare. If access to piece count mode is disabled, pressing the GROSS/NET key switches between gross and net modes only.

Gross mode is shown by the G annunciator; net mode is shown by the N annunciator. Piece count mode is shown by the LCD annunciator adjacent to the PC at the right edge of the display.

1.4.2 Toggle Units

Press the UNITS key to switch between primary and secondary units. The units annunciator arrow on the right side of the LCD display points to the units identifier.

1.4.3 Zero Scale

1. In gross mode, remove all weight from the scale and wait for the standstill annunciator (▲▲).
2. Press the ZERO key. The center of zero (→0←) annunciator lights to indicate the scale is zeroed.

1.4.4 Acquire Tare

1. Place container on scale and wait for the standstill annunciator (▲▲).
2. Press the TARE key to acquire the tare weight of the container.
3. Net weight is displayed and the T annunciator lit to show the tare value was acquired.

1.4.5 Remove Stored Tare Value

1. Remove all weight from the scale and wait for the standstill annunciator (▲▲).
2. Press the ZERO key. The T annunciator goes off, indicating the tare value has been removed.

1.4.6 Print Ticket

1. Wait for the standstill annunciator (▲▲).
2. Press the PRINT key to send data to the serial port.

1.4.7 Acquire Parts Sample

1. Place empty parts container on scale. Wait for the standstill annunciator (▲▲), then press TARE to acquire the tare weight of the container.
2. Press MODE to enter piece count mode.
3. Press the SAMPLE (UNITS) key to enter sample acquisition mode.
4. The indicator display shows the message *Addnnn*, where *nnn* is the sample quantity to be placed on the scale. Add the number of parts shown or choose a different sample size by pressing the SAMPLE key to scroll through the selectable sample quantities (5, 10, 20, 50, 100).
5. Once the sample quantity is on the scale, press ENTER to calibrate the indicator for counting the new parts. The indicator display shows the message *-CNT-* as it acquires the sample weight, then switches to count display mode and shows the part quantity.

2.0 Installation

This section describes procedures for connecting load cell and serial communications cables to the IQ plus 390-DC indicator. Instructions for battery and CPU board replacement are included, along with assembly drawings and parts lists for the service technician.

Caution Use a wrist strap to ground yourself and protect components from electrostatic discharge (ESD) when working inside the indicator enclosure.

2.1 Unpacking and Assembly

Immediately after unpacking, visually inspect the IQ plus 390-DC to ensure all components are included and undamaged. The shipping carton should contain the indicator with attached tilt stand, this manual, and a parts kit. If any parts were damaged in shipment, notify Rice Lake Weighing Systems and the shipper immediately.

The parts kit contains the items listed below:

- Capacity and identification labels. Identification label (PN 49958) includes replacement overlay decals for indicators using units other than pounds and kilograms.
- 3-position (PN 15888) and 7-position (PN 23165) pluggable terminal blocks for load cell

and serial communications connectors.

- One 8-32NC x 7/16 fillister head screw (PN 30623). This screw occupies the hole below the setup switch access screw on the indicator backplate (see Figure 2-3 on page 6).
- Four 8-32NC x 3/8 machine screws (PN 14862) for the indicator backplate (see #10 in Figure 2-6 on page 8).
- Five neoprene washers (PN 45042) for backplate screws included in the parts kit.
- Four rubber bumpers (“feet”) for the tilt stand, PN 42149.
- One 250 mA replacement fuse (PN 35993).

2.2 Enclosure Disassembly

The indicator enclosure must be opened to connect load cell and communications cables.

Power-off the indicator and disconnect the AC adapter, if necessary. Place the indicator face-down on an antistatic work mat. Remove the screws that hold the backplate to the enclosure body, then lift the backplate away from the enclosure. Disconnect battery cable to connector J3, then set the backplate assembly aside.

2.3 Cable Connections

The IQ plus 390-DC provides two cord grips for cabling into the indicator: one for the load cell cable, the other for serial communications.

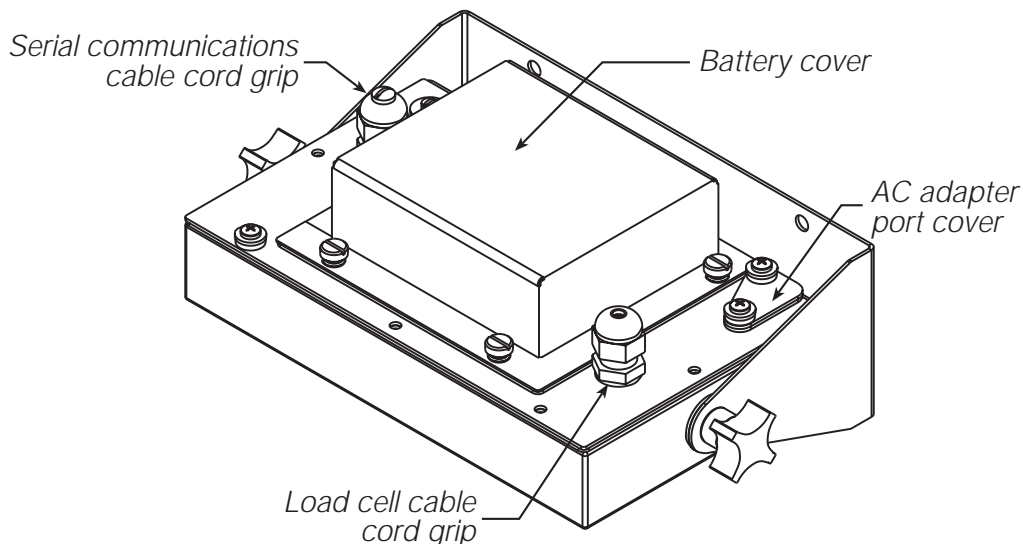

Figure 2-1. IQ plus 390-DC Backplate, Showing Key Component Locations

2.3.1 Load Cells

To attach cable from a load cell or junction box, remove connector J1 from the board. The connector plugs into a header on the board. Connect cable from the load cell or junction box through the load cell cable cord grip to connector J1 as shown in Table 2-1. If using 6-wire load cell cable (with sense wires), remove jumpers JP1 and JP2 before reinstalling connector J1 (see Figure 2-2). For 4-wire installation, leave jumpers JP1 and JP2 on.

When connections are complete, reinstall connector J1 on the board.

J1 Pin	Function
1	+SIG
2	-SIG
3	+SENSE
4	-SENSE
5	SHIELD
6	+EXC
7	-EXC
For 6-wire load cell connections, remove jumpers JP1 and JP2.	

Table 2-1. J1 Pin Assignments

2.3.2 Serial Communications

To attach serial communications cables, remove connector J2 from the board (see Figure 2-2). Connect communications cable through cord grip to connector J2 as shown in Table 2-2.

Once cables are attached, reconnect J2 to the header on the board.

The IQ plus 390-DC serial port supports full duplex RS-232 communications for connections to printers, PCs, and other attached devices. See Section 3.0 on page 9 for general configuration information; see Section 3.2.4 on page 17 for serial port configuration.

J2 Pin	Function
1	RS-232 TxD
2	RS-232 Ground
3	RS-232 RxD

Table 2-2. J2 Pin Assignments

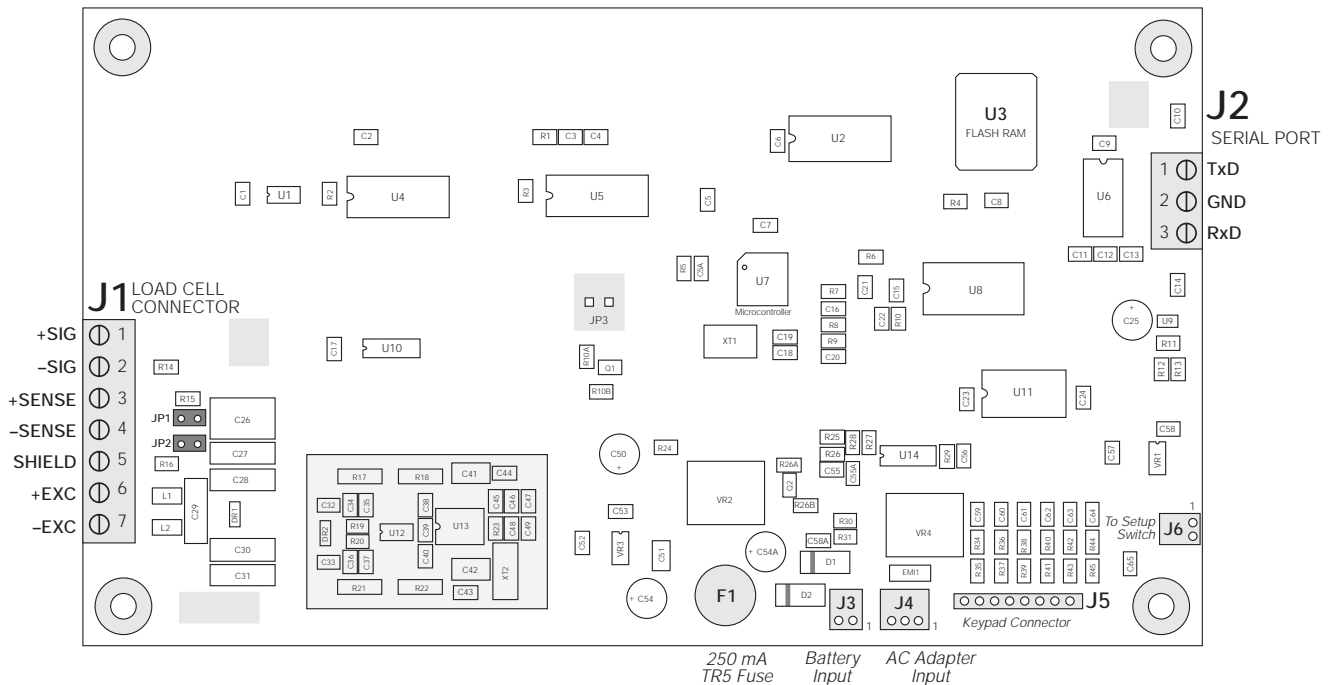

Figure 2-2. IQ plus 390-DC CPU Board

2.4 Enclosure Reassembly

Once cabling is complete, position the backplate over the enclosure, reconnect battery cable, and reinstall the backplate screws. Use the torque pattern shown in Figure 2-3 to prevent distorting the backplate gasket. Torque screws to 15 in-lb (1.7 N-m).

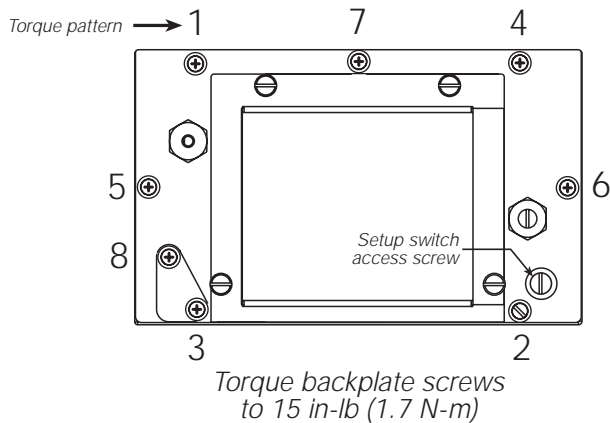

Figure 2-3. IQ plus 390-DC Enclosure Backplate

2.5 Battery Installation

To install or replace batteries, do the following:

1. Remove the four thumbscrews that hold the battery cover to the enclosure backplate.
2. Install six alkaline C-cell batteries as shown in Figure 2-4.
3. Replace the battery cover and reinstall thumbscrews. Torque thumbscrews to 15 in-lb (1.7 N-m).

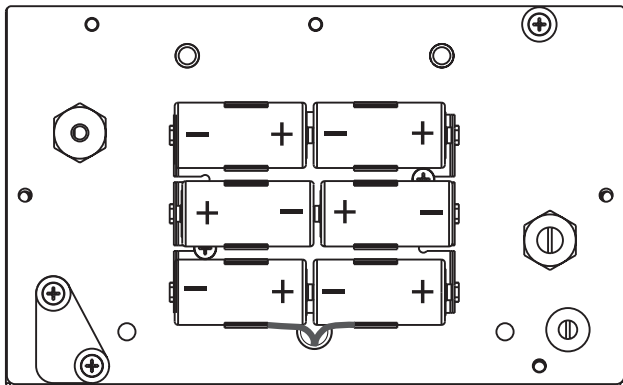

Figure 2-4. Battery Installation

2.6 AC Adapter

The AC adapter can be used to provide power to the indicator if battery power is low and AC power is available. Use only the adapter supplied with the indicator.

To use the AC adapter, do the following:

1. Remove the top screw from the AC adapter port cover.
2. Loosen the bottom screw, then rotate the port cover to expose the AC adapter port (see Figure 2-5).
3. Reinstall the top screw in the backplate.
4. Plug AC adapter from power outlet to the indicator adapter port.

Close the adapter port cover and reinstall screws as described in Section 2.4 when not using the AC adapter.

Caution The IQ plus 390-DC enclosure cannot be rated for NEMA 4X/IP66 applications with the AC adapter port cover open.

Do not use the AC adapter in washdown environments.

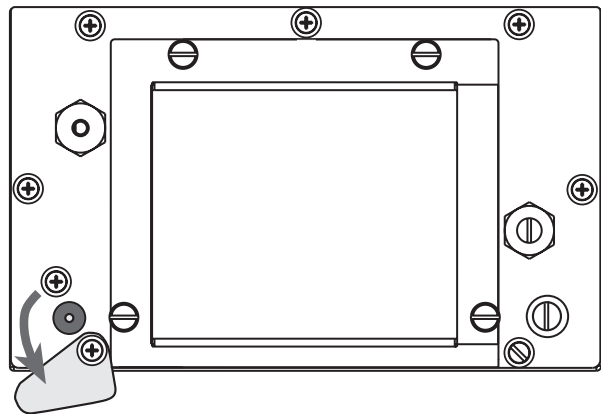

Figure 2-5. AC Adapter Port Cover

2.7 Board Removal

If you must remove the IQ plus 390-DC CPU board, use the following procedure:

1. Disconnect power to the indicator. Loosen cord grips and remove backplate as described in Section 2.2 on page 4.
2. Unplug all connections to the CPU board. See Figure 2-2 on page 5 for connector locations.
3. Remove the four nuts from the corners of the CPU board.
4. Remove the CPU board from the enclosure.

To replace the CPU board, reverse the above procedure. Be sure to reinstall cable ties to secure all cables inside the indicator enclosure. Replace backplate and torque screws as shown in Figure 2-3.

2.8 Replacement Parts

Table 2-3 lists replacement parts for the IQ plus 390-DC, including all parts referenced in Figure 2-6 on page 8.

Ref Number	PN	Description (Quantity)
1	49520	Battery cover thumb screws (4)
2	47939	Battery cover (1)
3	49557	Battery cover gasket (1)
4	49909	Battery holder assembly (1)
5	19538	Cable grip plug (1)
6	42640	Setup switch access screw, 1/4 x 28NF x 1/4 (1)
7	15626	Cable grips, PG9 (2)
8	44676	Sealing washer for setup switch access screw, #14 (1)
9	30375	Nylon seal rings for cable grips (2)
10	14862*	Screws, 8-32NC x 3/8 (2)
11	45042	Sealing washers, #8 (3)
12	47940	Enclosure backplate (1)
13	15627	Locknuts, PCN9 (2)
14	49558	Backplate gasket (1)
15	14626	Kep nuts, 6-32NC hex (4)
16	49954	Display and CPU board assembly (1)
17	47941	Enclosure (1)
18	48790	Overlay membrane panel (1)
19	49953	Screw, 8-32NC x 1/2 (1)
20	49906	AC adapter port cover (1)
21	49904	AC adapter port gasket (1)
23	48119	Tilt stand (1)
24	30342	Wing knobs for tilt stand (2)
25	15144	Nylon washers for tilt stand, 1/4 x 1 x 1/16 (2)
26	49908	AC adapter connector assembly (1)
27	41980	Nylon spacers for board mounting (4)
28	49905	Battery cover pad (1)
29	49953	Phillips pan head screws, 8-32NC x 1/2 (2)
30	49910	Setup switch assembly (1)
32	15631*	Cable tie (1)
33	15650*	Cable tie mount (1)
34	—	Serial tag (1)
—	49978	AC adapter, 115 VAC (1)
—	49977	AC adapter, 230 VAC (1)
—	35993	250 mA TR5 subminiature fuse (1)
* Additional parts included in parts kit.		
 Caution For protection against risk of fire, replace fuse only with same type and rating fuse. See Section 8.8 on page 39 for complete fuse specifications.		

Table 2-3. Replacement Parts

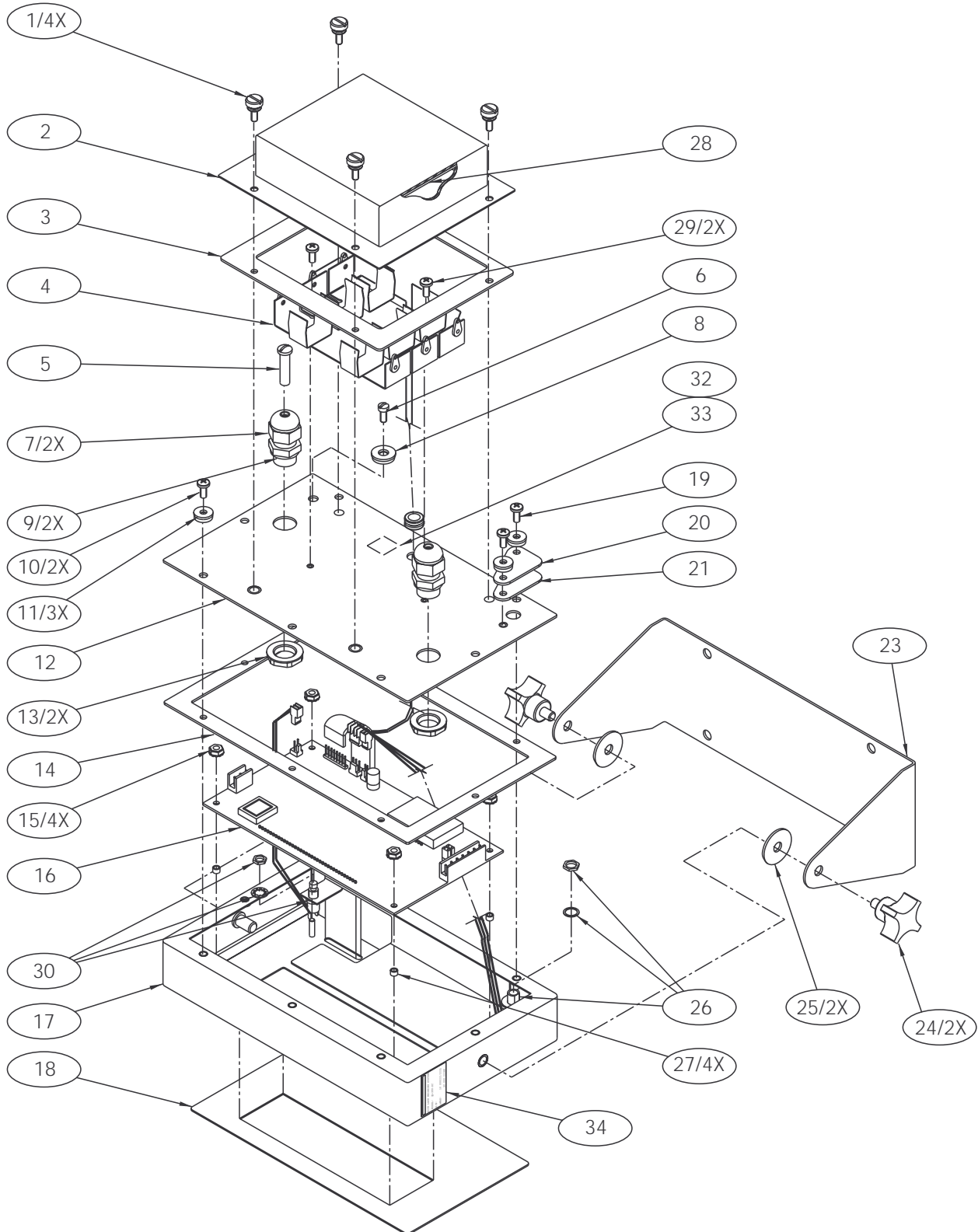

Figure 2-6. IQ plus 390-DC Assembly

3.0 Configuration

To configure the IQ plus 390-DC indicator, the indicator must be placed in setup mode. The setup switch is accessed by removing the large fillister head screw on the enclosure backplate. Switch position is changed by inserting a screwdriver into the access hole and pressing the switch.

When the indicator is placed in setup mode, the word *CONFIG* is shown on the display. The CONFIG menu is the first of seven main menus used to configure the indicator. Detailed descriptions of these menus are given in Section 3.2. When configuration is complete, return to the CONFIG menu and press the Δ (ZERO) key to exit setup mode, then replace the setup switch access screw.

3.1 Configuration Methods

The IQ plus 390-DC indicator can be configured by using the front panel keys to navigate through a series of configuration menus or by sending commands or configuration data to the EDP port. Configuration using the menus is described in Section 3.1.3.

Configuration using the EDP port can be accomplished using either the EDP command set described in Section 5.0 or the Revolution™ Scaleware configuration utility.

3.1.1 Revolution Scaleware Configuration

The Revolution Scaleware configuration utility provides the preferred method for configuring the IQ plus 390-DC indicator. Revolution runs on a personal computer to set configuration parameters for the indicator. When Revolution configuration is complete, configuration data is downloaded to the indicator.



Figure 3-1. Sample Revolution Scaleware Format Display

Revolution supports both uploading and downloading of indicator configuration data. This capability allows configuration data to be retrieved from one indicator, edited, then downloaded to another.

To use Revolution Scaleware, do the following:

1. Install Revolution on an IBM-compatible personal computer running Windows® 3.11 or Windows 95. Minimum system requirements are 4MB of extended memory and at least 5MB of available hard disk space.
2. With both indicator and PC powered off, connect the PC serial port to the RS-232 pins on the indicator EDP port.
3. Power up the PC and the indicator. Use the setup switch to place the indicator in setup mode.
4. Start the Revolution Scaleware program.

Figure 3-1 shows an example of one of the Revolution Scaleware configuration displays.

Revolution provides online help for each of its configuration displays. Parameter descriptions provided in this manual for front panel configuration can also be used when configuring the indicator using Revolution: the interface is different, but the parameters set are the same.

3.1.2 EDP Command Configuration

The EDP command set can be used to configure the IQ plus 390-DC indicator using a personal computer, terminal, or remote keyboard. Like Revolution, EDP command configuration sends commands to the indicator EDP port; unlike Revolution, EDP commands can be sent using any external device capable of sending ASCII characters over a serial connection.

EDP commands duplicate the functions available using the indicator front panel and provide some functions not otherwise available. EDP commands can be used to simulate pressing front panel keys, to configure the indicator, or to dump lists of parameter settings. See Section 5.0 on page 23 for more information about using the EDP command set.

3.1.3 Front Panel Configuration

The IQ plus 390-DC indicator can be configured using a series of menus accessed through the indicator front panel when the indicator is in setup mode. Table 3-1 summarizes the functions of each of the main menus.

Menu		Menu Function
CONFIG	Configuration	Configure grads, zero tracking, zero range, motion band, overload, tare function, and digital filtering parameters.
FORMAT	Format	Set format of primary and secondary units, display rate.
CALIBR	Calibration	Calibrate indicator. See Section 4.0 on page 21 for calibration procedures.
SERIAL	Serial	Configure serial port.
PROGRM	Program	Set power-up and standby modes, counting scale functions, regulatory mode, unit ID and consecutive number values.
P FORMT	Print Format	Set print format used for gross, net, and counting scale tickets. See Section 7.0 on page 28 for more information.
VERSION	Version	Display installed software version number.

Table 3-1. IQ plus 390-DC Menu Summary

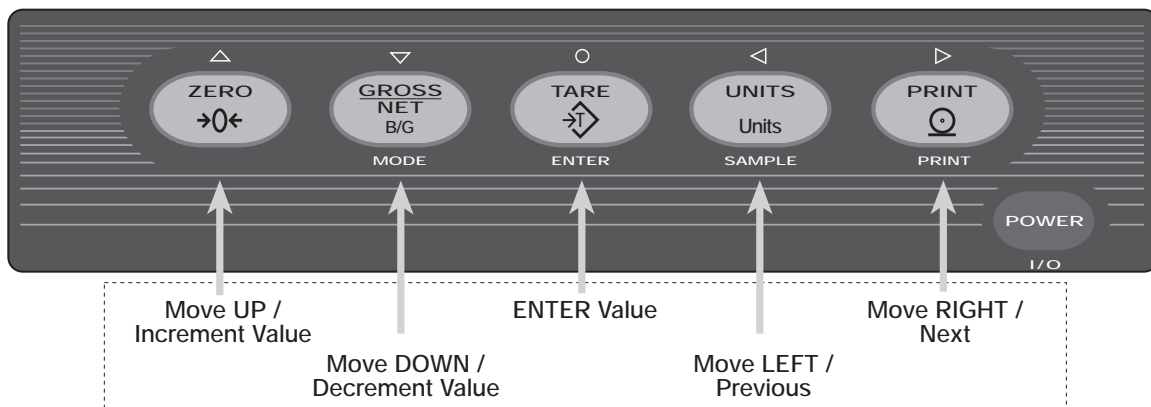

SETUP MODE KEY FUNCTIONS

Figure 3-2. Front Panel Key Functions in Setup Mode

Four front panel keys are used as directional keys to navigate through the menus in setup mode (see Figure 3-2). The UNITS (◀) and PRINT (▶) keys scroll left and right (horizontally) on the same menu level; ZERO (△) and GROSS/NET (▽) move up and down (vertically) to different menu levels. The TARE key (○) serves as an Enter key for selecting parameter values within the menus. A label over each of these keys identifies the direction provided by the key when navigating through the setup menus.

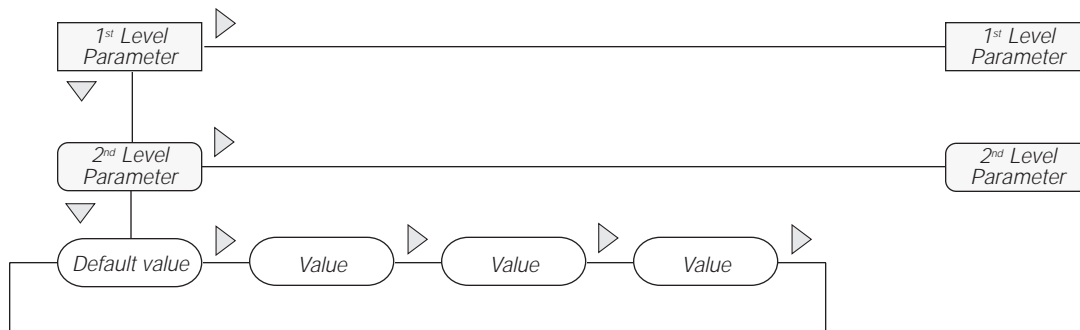

When moving through values below the first menu level, press △ to return to the level above. Press ○ or ▽ to move to the next parameter on the level above.

Figure 3-3. Setup Mode Menu Navigation

To select a parameter, press ◀ or ▶ to scroll left or right until the desired menu group appears on the display, then press ▼ to move down to the submenu or parameter you want. When moving through the menu parameters, the default or previously selected value appears first on the display.

To change a parameter value, scroll left or right to view the values for that parameter. When the desired value appears on the display, press ○ to select the value and move back up one level.

To edit numeric values, use the navigation keys to select the digit and to increment or decrement the value. Press ○ to enter the numeric value, then use the ◀ or ▶ key to adjust the decimal point position, if necessary. Press ○ again to save the value and exit the parameter (see Figure 3-4).



When editing numeric values, press ◀ or ▶ to change the digit selected. Press ▲ or ▼ to increment or decrement the value of the selected digit. Press ○ to save the value.



After entering the value, press ◀ or ▶ to change the decimal point location. Press ○ again to save the value and exit the parameter.

Figure 3-4. Editing Procedure for Numeric Values

3.2 Menu Structures and Parameter Descriptions

The following sections provide graphic representations of the IQ plus 390-DC menu structures. In the actual menu structure, the settings you choose under each parameter are arranged horizontally. To save page space, menu choices are shown in vertical columns. The factory default setting appears at the top of each column.

Most menu diagrams are accompanied by a table that describes all parameters and parameter values associated with that menu. Default parameter values are shown in bold type.

NOTE: Some characters cannot be accurately represented on the 7-segment front panel LCD display. Section 8.4 on page 34 lists the 7-segment character set and the alphanumerics they represent.

3.2.1 Configuration Menu

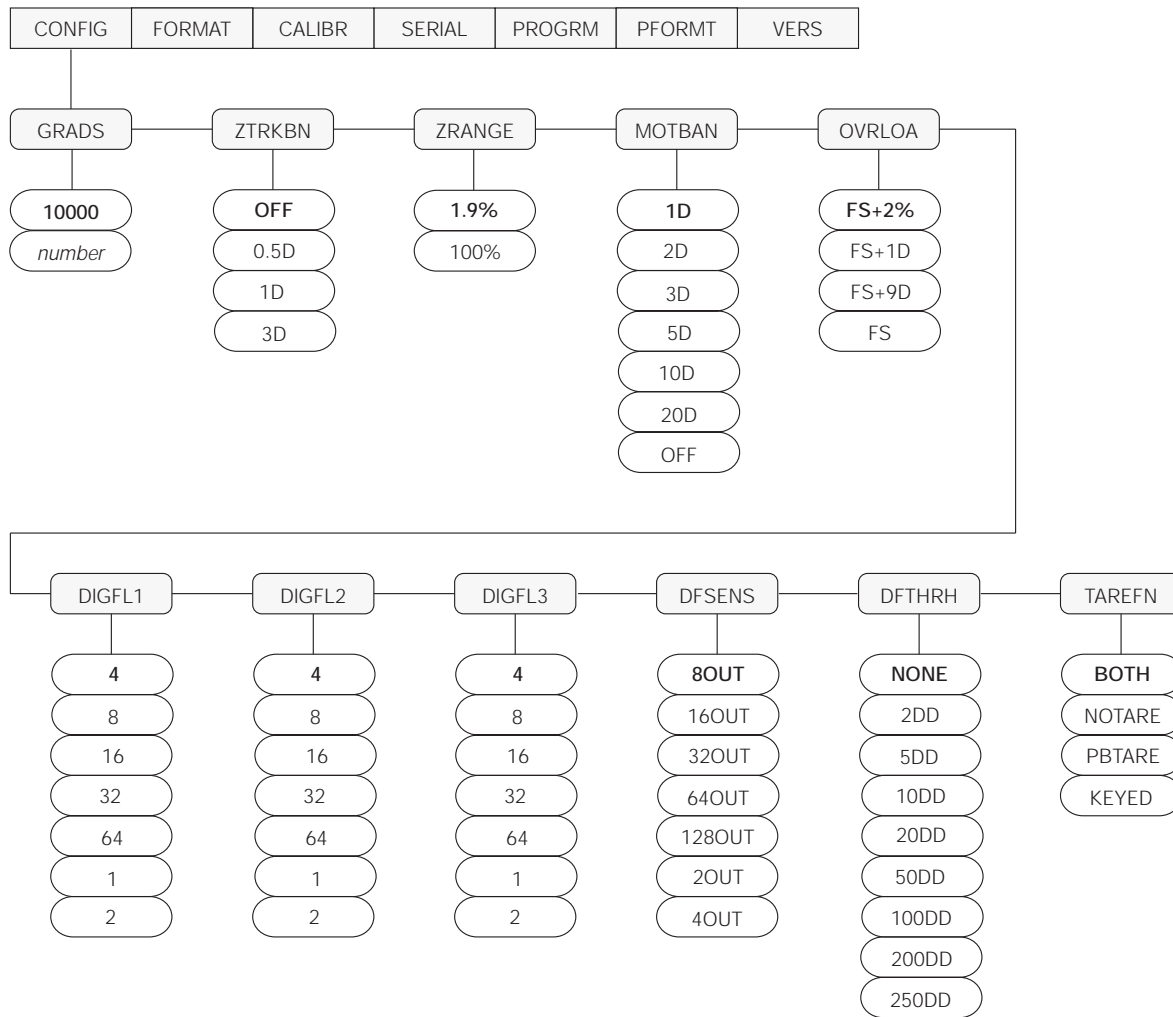

Figure 3-5. Configuration Menu

CONFIG Menu		
Parameter	Choices	Description
<i>Level 2 submenus</i>		
GRADS	10000 number	Graduations. Specifies the number of full scale graduations. The value entered must be in the range 1–999 999 and should be consistent with legal requirements and environmental limits on system resolution. To calculate GRADS, use the formula, $GRADS = Capacity / Display Divisions$. Display divisions for primary and secondary units are specified on the FORMAT menu.
ZTRKBN	OFF 0.5D 1D 3D	Zero track band. Automatically zeroes the scale when within the range specified, as long as the input is within the ZRANGE and scale is at standstill. Selections are \pm display divisions. Maximum legal value varies depending on local regulations.
ZRANGE	1.9% 100%	Zero range. Selects the range within which the scale can be zeroed. The 1.9% selection is $\pm 1.9\%$ around the calibrated zero point, for a total range of 3.8%. Indicator must be at standstill to zero the scale. Use 1.9% for legal-for-trade applications.

Table 3-2. Configuration Menu Parameters

CONFIG Menu		
Parameter	Choices	Description
MOTBAN	1D 2D 3D 5D 10D 20D OFF	Motion band. Sets the level, in display divisions, at which scale motion is detected. If motion is not detected for 1 second or more, the standstill symbol lights. Some operations, including print, tare, and zero, require the scale to be at standstill. Maximum legal value varies depending on local regulations. If OFF is selected, ZTRKBN is disabled.
OVRL0A	FS+2% FS+1D FS+9D FS	Overload. Determines the point at which the display blanks and an out-of-range error message is displayed. Maximum legal value varies depending on local regulations.
DIGFL1 DIGFL2 DIGFL3	4 8 16 32 64 1 2	Digital filtering. Selects the digital filtering rate used to reduce the effects of mechanical vibration from the immediate area of the scale. Choices indicate the number of A/D conversions that are averaged to obtain the displayed reading. A higher number gives a more accurate display by minimizing the effect of a few noisy readings, but slows down the settling rate of the indicator. See Section 8.6 on page 36 for more information on digital filtering.
DFSENS	8OUT 16OUT 32OUT 64OUT 128OUT 2OUT 4OUT	Digital filter cutout sensitivity. Specifies the number of consecutive readings that must fall outside the filter threshold (DFTHRH parameter) before digital filtering is suspended.
DFTHRH	NONE 2DD 5DD 10DD 20DD 50DD 100DD 200DD 250DD	Digital filter cutout threshold. Specifies the filter threshold, in display divisions. When a specified number of consecutive scale readings (DFSENS parameter) fall outside of this threshold, digital filtering is suspended.
TAREFN	BOTH NOTARE PBTARE KEYED	Tare function. Enables or disables push-button and keyed tares. Possible values are: BOTH: Both push-button and keyed tares are enabled NOTARE: No tare allowed (gross mode only) PBTARE: Push-button tares enabled KEYED: Keyed tare enabled

Table 3-2. Configuration Menu Parameters (Continued)

3.2.2 Format Menu

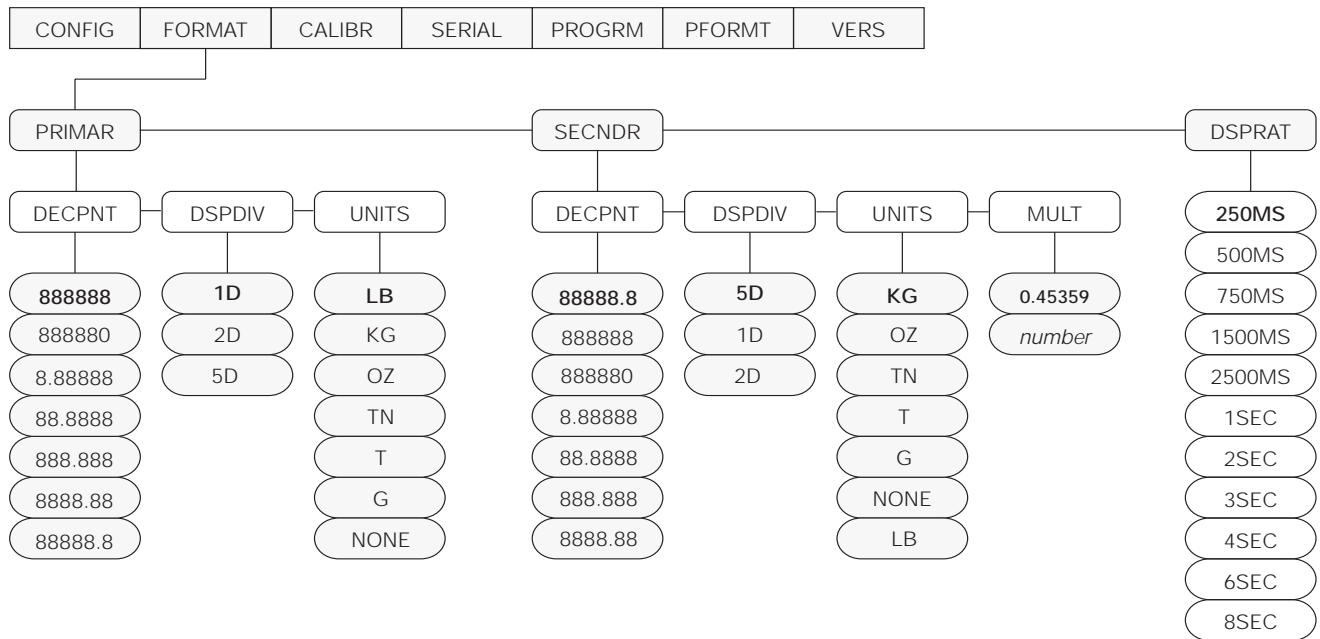

Figure 3-6. Format Menu

FORMAT Menu		
Parameter	Choices	Description
<i>Level 2 submenus</i>		
PRIMAR	DECPNT DSPDIV UNITS	Specifies the decimal position, display divisions, and units used for the primary units. See Level 3 submenu parameter descriptions.
SECNDR	DECPNT DSPDIV UNITS MULT	Specifies the decimal position, display divisions, units, and conversion multiplier used for the secondary units. See Level 3 submenu parameter descriptions.
DSPRAT	250MS 500MS 750MS 1500MS 2500MS 1SEC 2SEC 3SEC 4SEC 6SEC 8SEC	Display rate. Sets the update rate for displayed values. Values are in milliseconds (MS) or seconds (SEC).

Table 3-3. Format Menu Parameters

FORMAT Menu		
Parameter	Choices	Description
<i>Level 3 submenus</i>		
Primary Units (PRIMAR Parameter)		
DECPNT	888888 888880 8.88888 88.8888 888.888 8888.88 88888.8	Decimal point location. Specifies the location of the decimal point or dummy zeroes in the primary unit display. Value should be consistent with local legal requirements.
DSPDIV	1D 2D 5D	Display divisions. Selects the minimum division size for the primary units displayed weight.
UNITS	LB KG OZ TN T G NONE	Specifies primary units for displayed and printed weight. Values are: LB=pound; KG=kilogram; OZ=ounce; TN=short ton; T=metric ton; G=gram. NOTE: Units sold outside North America are configured with KG for both primary and secondary units.
Secondary Units (SECNDR Parameter)		
DECPNT	88888.8 888888 888880 8.88888 88.8888 888.888 8888.88	Decimal point location. Determines the location of the decimal point or dummy zeros in the secondary unit display.
DSPDIV	5D 1D 2D	Display divisions. Selects the value of minimum division size of the displayed weight.
UNITS	KG OZ TN T G LB NONE	Specifies secondary units for displayed and printed weight. Values are: KG=kilogram; OZ=ounce; TN=short ton; T=metric ton; G=gram; LB=pound.
MULT	0.45359 <i>Enter other choices via keyboard</i>	Multiplier. Specifies the conversion factor by which the primary units are multiplied to obtain the secondary units. The default is 0.45359, which is the conversion factor for changing pounds to kilograms. See Section 8.5 on page 35 for a list of multipliers. To toggle between primary and secondary units, press the UNITS key.

Table 3-3. Format Menu Parameters (Continued)

3.2.3 Calibration Menu

See Section 4.0 on page 21 for calibration procedures.

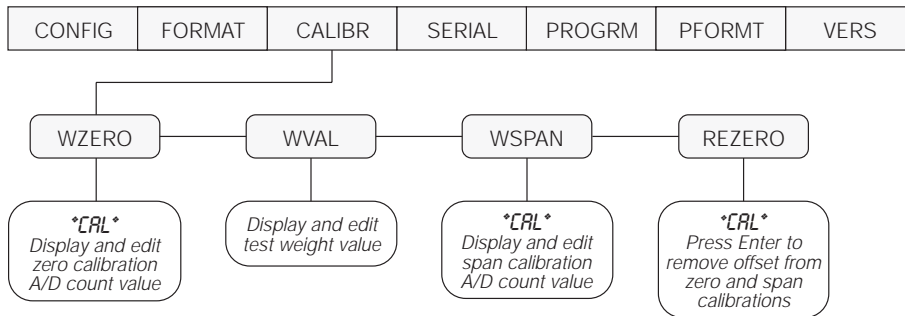

Figure 3-7. Calibration Menu

CALIBR Menu		
Parameter	Choices	Description
<i>Level 2 submenus</i>		
WZERO	—	Calibrate zero, display and edit the zero calibration A/D count value.
WVAL	—	Display and edit the test weight value.
WSPAN	—	Calibrate span, display and edit the span calibration A/D count value.
REZERO	—	Press Enter to remove an offset value from the zero and span calibrations.

Table 3-4. Calibration Menu Parameters

3.2.4 Serial Menu

See Section 8.2 on page 31 for information about the IQ plus 390-DC serial data format.

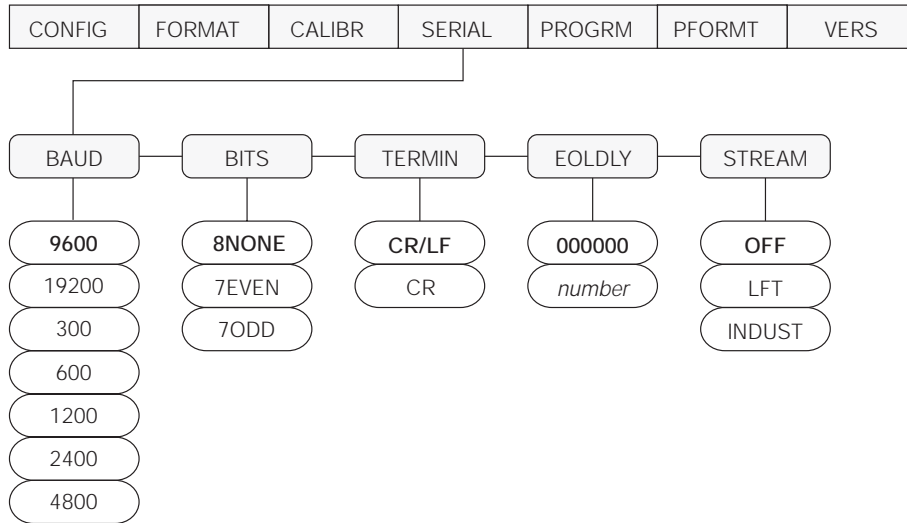

Figure 3-8. Serial Menu

SERIAL Menu		
Parameter	Choices	Description
<i>Level 2 Submenus</i>		
BAUD	9600 19200 300 600 1200 2400 4800	Baud rate. Selects the transmission speed for the EDP port.
BITS	8NONE 7EVEN 7ODD	Selects number of data bits and parity of data transmitted from the EDP port.
TERMIN	CR/LF CR	Termination character. Selects termination character for data sent from the EDP port.
EOLDLY	0 <i>number</i>	End-of-line delay. Sets the delay period, in 0.1-second intervals, from when a formatted line is terminated to the beginning of the next formatted serial output. Value specified must be in the range 0-255, in tenths of a second (10 = 1 second).
STREAM	OFF LFT INDUST	Selects whether continuous data output is streamed from the serial port. Select LFT for legal-for-trade applications in which the streamed data must match the current displayed weight. Select INDUST to stream the latest weight data, regardless of the value displayed. See Section 8.2 on page 31 for information about the IQ plus 390-DC continuous data format.

Table 3-5. Serial Menu Parameters

3.2.5 Program Menu

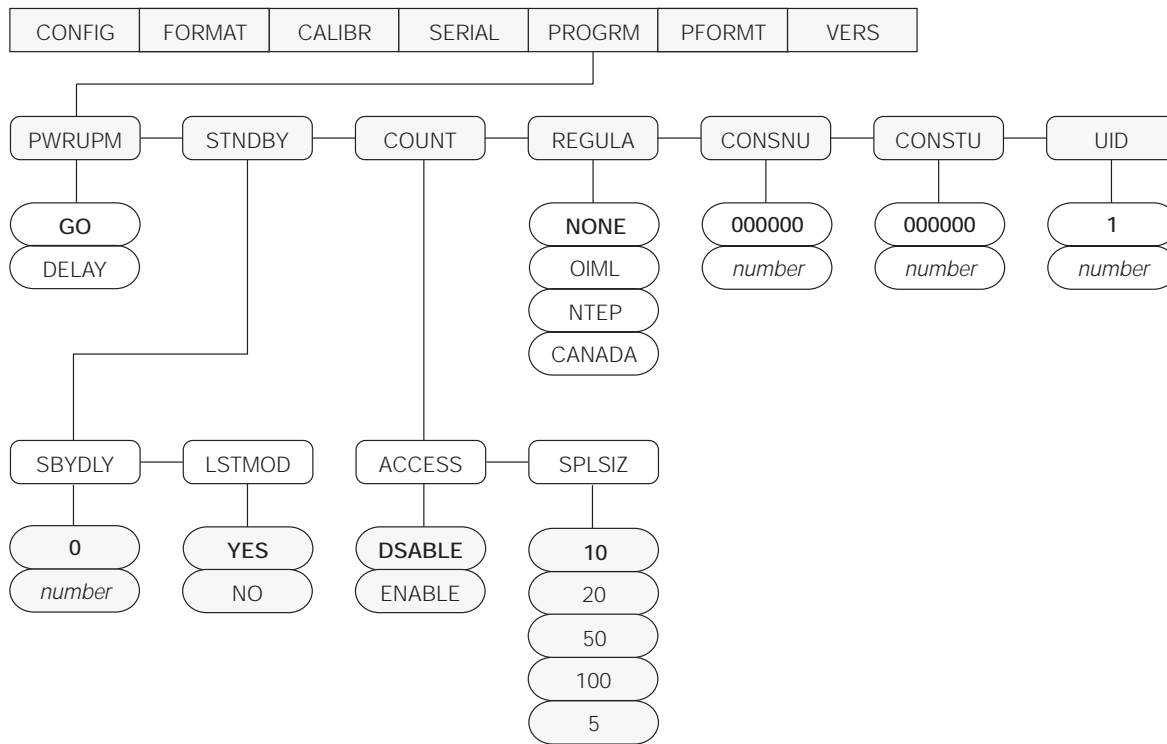

Figure 3-9. ProgramMenu

PROGRM Menu		
Parameter	Choices	Description
<i>Level 2 submenus</i>		
PWRUPM	GO DELAY	Power up mode. In GO mode, the indicator goes into operation immediately after a brief power up display test. In DELAY mode, the indicator performs a power up display test, then enters a 30-second warm up period. If no motion is detected during the warm up period, the indicator becomes operational when the warm up period ends; if motion is detected, the delay timer is reset and the warm up period repeated.
STNDBY	SBYDLY LSTMOD	Specifies standby mode delay and whether indicator returns to the last operating mode or performs a power-up sequence when standby mode ends. See Level 3 submenu parameter descriptions.
COUNT	ACCESS SPLSIZ	Specifies whether operator has access to piece count mode and the default sample size used for parts counting. See Level 3 submenu parameter descriptions.
REGULA	NONE OIML NTEP CANADA	Regulatory mode. Specifies the regulatory agency having jurisdiction over the scale site. OIML and CANADA modes require the scale load to be at zero before clearing a tare.

Table 3-6. Program Menu Parameters

PROGRM Menu		
Parameter	Choices	Description
CONSNU	000000 <i>number</i>	Consecutive numbering. Allows sequential numbering for print operations. The consecutive number value is incremented following each print operation. The initial value of this parameter is set to the start up value specified on the CONSTU parameter. Changing either CONSTU or CONSNU immediately resets the consecutive number used for printing.
CONSTU	000000 <i>number</i>	Consecutive number start up value. Specifies the initial consecutive number (CONSNU) value used when the indicator is powered on.
UID	1 <i>number</i>	Unit ID. Specify a unit identifier for the indicator in the range 1–999999. The unit ID can be added to print ticket formats to identify the indicator used to generate the ticket.
Level 3 submenus		
SBYDLY	0 <i>number</i>	Standby mode delay. Specifies the number of minutes the indicator must be inactive before entering standby mode. Valid values are 0 (off) or 1–120 minutes. The indicator enters standby mode if no key presses, serial communications, or scale motion occur for the length of time specified on this parameter. Set this parameter to 0 to disable standby mode.
LSTMOD	YES NO	Last mode. Specifies whether the indicator resumes operation in the last mode it was in before entering standby mode (YES) or performs the standard power-up sequence (NO).
ACCESS	DSABLE ENABLE	Operator access to piece count mode. Specify DSABLE if piece count mode will not be used. With access disabled, pressing the GROSS/NET (MODE) key toggles between gross and net modes only.
SPLSIZ	10 20 50 100 5	Sample size. Specify the default sample size used for counting scale operations. Sample size can be changed in counting mode during sample acquisition.

Table 3-6. Program Menu Parameters (Continued)

3.2.6 Print Format Menu

See Section 7.0 on page 28 for information about custom print formatting.

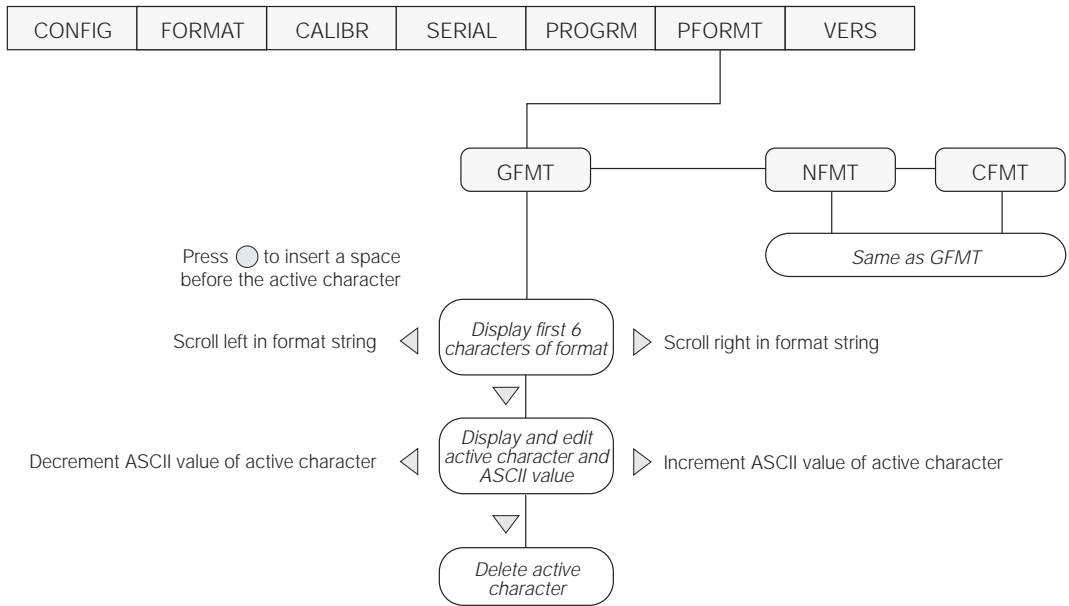

Figure 3-10. Print Format Menu

3.2.7 Version Menu

The VERS menu is used to check the software version installed in the indicator. There are no parameters associated with the Version menu: when selected, the indicator displays the installed software version number.

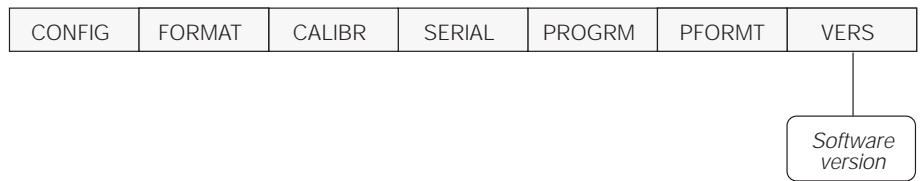

Figure 3-11. Version Menu

4.0 Calibration

The IQ plus 390-DC can be calibrated using the front panel, EDP commands, or the Revolution™ Scaleware configuration utility. Each method consists of the following steps:

- Zero calibration
- Entering the test weight value
- Span calibration
- Optional rezero calibration for test weights using hooks or chains.

The following sections describe the calibration procedure for each of the calibration methods.

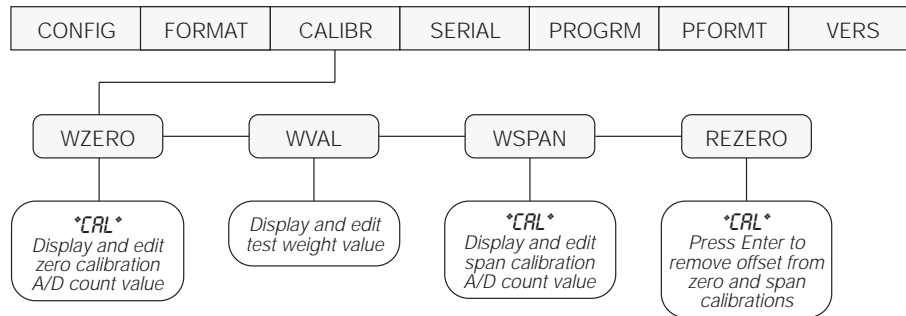

Figure 4-1. Calibration (CALIBR) Menu

4.1 Front Panel Calibration

To calibrate the indicator using the front panel, do the following:

1. Place the indicator in setup mode (display reads *CONFIG*) and remove all weight from the scale platform. If your test weights require hooks or chains, place the hooks or chains on the scale for zero calibration.
2. Press \triangleright until the display reads *CALIBR* (see Figure 4-1). Press ∇ to go to zero calibration (*WZERO*).
3. With *WZERO* displayed, press \bigcirc to calibrate zero. The indicator displays **CAL** while calibration is in progress. When complete, the A/D count for the zero calibration is displayed. Press \bigcirc again to save the zero calibration value and go to the next prompt (*WVAL*).
4. With *WVAL* displayed, place test weights on the scale and press \bigcirc to show the test weight value. Use the procedure shown in Figure 4-2 to enter the actual test weight, then press \bigcirc to save the value and go to span calibration (*WSPAN*).
5. With *WSPAN* displayed, press \bigcirc to calibrate span. The indicator displays **CAL** while calibration is in progress. When complete, the A/D count for the span calibration is displayed. Press \bigcirc again to save the span calibration value and go to the next prompt (*REZERO*).
6. The rezero function is used to remove a calibration offset when hooks or chains are used to hang the test weights.
 - If no other apparatus was used to hang the test weights during calibration, remove the test weights and press \triangle to return to the *CALIBR* menu.
 - If hooks or chains were used during calibration, remove these and the test weights from the scale. With all weight removed, press \bigcirc to rezero the scale. This function adjusts the zero and span calibration values. The indicator displays **CAL** while the zero and span calibrations are adjusted. When complete, the adjusted A/D count for the zero calibration is displayed. Press \bigcirc to enter the value, then press \triangle to return to the *CALIBR* menu.



When editing numeric values, press \triangleleft or \triangleright to change the digit selected. Press \triangle or ∇ to increment or decrement the value of the selected digit. Press \bigcirc to save the value.



After entering the value, press \triangleleft or \triangleright to change the decimal point location. Press \bigcirc again to save the value and exit the parameter.

Figure 4-2. Editing Procedure for Numeric Values

7. Press \triangleleft until the display reads *CONFIG*, then press \triangle to exit setup mode.

4.2 EDP Command Calibration

To calibrate the indicator using EDP commands, the indicator EDP port must be connected to a terminal or personal computer. See Section 2.3.2 on page 5 for EDP port pin assignments; see Section 5.0 on page 23 for more information about using EDP commands.

Once the indicator is connected to the sending device, do the following:

1. Place the indicator in setup mode (display reads *CONFIG*) and remove all weight from the scale platform. If your test weights require hooks or chains, place the hooks or chains on the scale for zero calibration.
2. Send the WZERO EDP command to calibrate zero. The indicator displays *CAL* while calibration is in progress.

3. Place test weights on the scale and use the WVAL command to enter the test weight value in the following format:

WVAL=nnnnnn<CR>

4. Send the WSPAN EDP command to calibrate span. The indicator displays *CAL* while calibration is in progress.
5. To remove an offset value, clear all weight from the scale, including hooks or chains used to hang test weights, then send the REZERO EDP command. The indicator displays *CAL* while the zero and span calibrations are adjusted.
6. Send the KUPARROW EDP command to exit setup mode.

4.3 Revolution™ Scaleware Calibration

To calibrate the indicator using Revolution Scaleware, the indicator EDP port must be connected to a PC running the Revolution configuration utility.

Use the following procedure to calibrate the indicator:

1. Select *Calibrate Indicator* from the Revolution Scaleware main menu.
2. On the Indicator Calibration display, select the indicator model (*IQ+390-DC*) and communications port, then click *OK*.
3. Revolution Scaleware uploads calibration data from the indicator then presents the information in a display like that shown in Figure 4-3.

4. Enter the *Value of Test Weight* to be used for span calibration then click *OK*.
5. The Zero Calibration dialog box prompts you to remove all weight from the scale. Clear the scale and click *OK* to begin zero calibration. **NOTE:** If your test weights require hooks or chains, place the hooks or chains on the scale for zero calibration.
6. When zero calibration is complete, the Span Calibration dialog box prompts you to place test weights on the scale for span calibration. Place test weights on the scale then click *OK*.
7. When calibration is complete, the *New Settings* fields of the Indicator Calibration display are filled in. Click *Exit* to save the new values and return to the Revolution Scaleware main menu; to restore the previous calibration values, click *Restore Settings*.



Figure 4-3. Revolution Scaleware Calibration Display

5.0 EDP Commands

The IQ plus 390-DC indicator can be controlled by a personal computer or remote keyboard connected to the indicator EDP port. Control is provided by a set of EDP commands that can simulate front panel key press functions, display and change setup parameters, and perform reporting functions. The EDP port provides the capability to print configuration data or to save that data to an attached personal computer. This section describes the EDP command set and procedures for saving and transferring data using the EDP port.

5.1 The EDP Command Set

The EDP command set can be divided into five groups: key press commands, reporting commands, the RESETCONFIGURATION special function command, parameter setting commands, and transmit weight data commands.

When the indicator processes an EDP command, it responds with the message *OK*. The *OK* response verifies that the command was received and has been executed. If the command is unrecognized or cannot be executed, the indicator responds with *??*.

The following sections list the commands and command syntax used for each of these groups.

5.1.1 Key Press Commands

Key press EDP commands (see Table 5-1) simulate pressing the keys on the front panel of the indicator. These commands can be used in both setup and weighing mode. Several of the commands serve as “pseudo” keys, providing functions that are not represented by a key on the front panel.

For example, to enter a 15-pound tare weight using EDP commands:

1. Type K1 and press ENTER (or RETURN).
2. Type K5 and press ENTER.
3. Type KTARE and press ENTER.

The indicator displays the  symbol when a tare has been entered and shifts the display to net mode.

Command	Function
KZERO	Press the ZERO key
KGROSSNET	Press the GROSS/NET key
KGROSS	Go to gross mode (pseudo key)
KNET	Go to net mode (pseudo key)
KCOUNT	Go to piece count mode (pseudo key)
KTARE	Press the TARE key
KUNITS	Press the UNITS key
KPRIM	Go to primary units (pseudo key)
KSEC	Go to secondary units (pseudo key)
KPRINT	Press the PRINT key
KLEFTARROW	In setup mode, move left in the menu
KRIGHTARROW	In setup mode, move right in the menu
KUPARROW	In setup mode, move up in the menu
KDOWNARROW	In setup mode, move down in the menu
K0	Press number 0 (zero)
K1	Press number 1
K2	Press number 2
K3	Press number 3
K4	Press number 4
K5	Press number 5
K6	Press number 6
K7	Press number 7
K8	Press number 8
K9	Press number 9
KDOT	Press the decimal point (.)
KENTER	Press the ENTER key

Table 5-1. Key Press EDP Commands

5.1.2 Reporting Commands

Reporting commands (see Table 5-2) send specific information to the EDP port. These commands can be used in both setup mode and normal mode.

Command	Function
DUMPALL	List all parameter values
VERSION	Write IQ plus 390-DC software version
RS	Reset the indicator
P	Write current displayed weight with units identifier. The P command returns the current displayed weight value to the EDP port, along with the units identifier. If the indicator is in an underrange or overload condition, the weight value is replaced with ##### (overload) or %%%%%%%%% (underrange).
S	Write one frame of stream format

Table 5-2. EDP Reporting Commands

5.1.3 The RESETCONFIGURATION Command

The RESETCONFIGURATION command can be used to restore all configuration parameters to their default values. Before issuing this command, the indicator must be placed in setup mode or test mode (press and hold setup switch for approximately four seconds to enter test mode).

Sending this command, followed by the RS (RESET) EDP command, is equivalent to using the DEFLT function on the TEST menu. See Section 8.7 on page 37 for more information about test mode and using the TEST menu. **NOTE:** All load cell calibration settings are lost when the RESETCONFIGURATION command is run.

5.1.4 Parameter Setting Commands

Parameter setting commands allow you to display or change the current value for a particular configuration parameter (Tables 5-3 through Table 5-8).

Current configuration parameter settings can be displayed in either setup mode or normal mode using the following syntax:

command<ENTER>

Most parameter values can be changed in setup mode only. Use the following command syntax when changing parameter values:

command=value<ENTER>

where *value* is either a number or a parameter value. Use no spaces before or after the equal (=) sign. If you type an incorrect command, the display reads ???. Changes to the parameters do not take effect until you exit setup mode.

For example, to set the motion band parameter to 5, type the following:

MOTBAND=5D<ENTER>

Command	Description	Values
GRADS	Graduations	1-999 999
ZTRKBD	Zero track band	OFF, 0.5D, 1D, 3D
ZRANGE	Zero range	1.9%, 100%
MOTBAND	Motion band	1D, 2D, 3D, 5D, 10D, 20D, OFF
OVRLOAD	Overload	FS+2%, FS+1D, FS+9D, FS
DIGFLTR1 DIGFLTR2 DIGFLTR3	Digital filtering	1, 2, 4, 8, 16, 32, 64
DFSENS	Digital filter cutout sensitivity	2OUT, 4OUT, 8OUT, 16OUT, 32OUT, 64OUT, 128OUT
DFTHRH	Digital filter cutout threshold	NONE, 2DD, 5DD, 10DD, 20DD, 50DD, 100DD, 200DD, 250DD
TAREFN	Tare function	BOTH, NOTARE, PBTARE, KEYED

Table 5-3. CONFIG EDP Commands

Command	Description	Values
PRI.DECPNT	Primary units decimal position	8.88888, 88.8888, 888.888, 8888.88, 88888.8, 888888, 888880
PRI.DSPDIV	Primary units display divisions	1D, 2D, 5D
PRI.UNITS	Primary units	LB, KG, OZ, TN, T, G, NONE
SEC.DECPNT	Secondary units decimal position	8.88888, 88.8888, 888.888, 8888.88, 88888.8, 888888, 888880
SEC.DSPDIV	Secondary units display divisions	1D, 2D, 5D
SEC.UNITS	Secondary units	LB, KG, OZ, TN, T, G, NONE
SEC.MULT	Secondary units multiplier	0.00000-999999
DSPRATE	Display rate	250MS, 500MS, 750MS, 1500MS, 2500MS, 1SEC, 2SEC, 3SEC, 4SEC, 6SEC, 8SEC

Table 5-4. FORMAT EDP Commands

Command	Description	Values
WZERO	Zero calibration	—
WVAL	Test weight value	<i>test_weight_value</i>
WSPAN	Span calibration	—
REZERO	Rezero	—
LC.CD	Set deadload coefficient	<i>value</i>
LC.CW	Set span coefficient	<i>value</i>

Table 5-5. CALIBR EDP Commands

Command	Description	Values
EDP.BAUD	Baud rate	300, 600, 1200, 2400, 4800, 9600, 19200
EDP.BITS	Data bits/parity	8NONE, 7EVEN, 7ODD
EDP.TERMIN	Termination character	CR/LF, CR
EDP.EOLDLY	End-of-line delay	0-255 (0.1-second intervals)
EDP.STREAM	Stream format	OFF, LFT, INDUST

Table 5-6. SERIAL EDP Commands

Command	Description	Values
PWRUPMD	Power up mode	GO, DELAY
SBYDLY	Standby delay	0-120
LSTMOD	Last mode	YES, NO
CNTMOD	Counting mode	ENABLE, DSABLE
SAMPSIZ	Default sample size	5, 10, 20, 50, 100
REGULAT	Regulatory compliance	NONE, OIML, NTEP, CANADA
CONSNUM	Consecutive number	0-999 999
CONSTUP	Consecutive number start-up value	0-999 999
UID	Unit identifier	0-999 999

Table 5-7. PROGRM EDP Commands

Command	Description	Values
GFMT	Gross demand print format string	See Section 7.0 on page 28 for detailed information
NFMT	Net demand print format string	
CFMT	Counting mode print format string	

Table 5-8. PFORMT EDP Commands

5.1.5 Normal Mode Commands

The serial transmit weight data commands (see Table 5-9) transmit data to the EDP port on demand. The transmit weight data commands are valid only in normal operating mode.

Command	Description	Response Format
SX	Start EDP streaming	OK or ??
EX	Stop EDP streaming	OK or ??
XG	Transmit gross weight in displayed units	<i>nnnnnn UU</i> where <i>nnnnnn</i> is the weight value, <i>UU</i> is the units.
XN	Transmit net weight in displayed units	
XT	Transmit tare weight in displayed units	
XG2	Transmit gross weight in non-displayed units	
XN2	Transmit net weight in non-displayed units	
XT2	Transmit tare weight in non-displayed units	
XC	Transmit current part count	

Table 5-9. Normal Mode EDP Commands

5.2 Saving and Transferring Data

Connecting a personal computer to the IQ plus 390-DC EDP port allows you to save indicator configuration data to the PC or to download configuration data from the PC to an indicator. The following sections describe the procedures for these save and transfer operations.

5.2.1 Saving Indicator Data to a Personal Computer

Configuration data can be saved to a personal computer connected to the EDP port. The PC must be running a communications program such as PROCOMMPLUS® or CROSSTALK®. See Section 2.3.2 on page 5 for information about serial communications wiring and EDP port pin assignments.

When configuring the indicator, ensure that the values set for the BAUD and BITS parameters on the SERIAL menu match the baud rate, bits, and parity settings configured for the serial port on the PC.

To save all configuration data, place the indicator in setup mode and send the DUMPALL EDP command to the indicator. The IQ plus 390-DC responds by sending all configuration parameters to the PC as ASCII-formatted text.

5.2.2 Downloading Configuration Data from PC to Indicator

Configuration data saved on a PC or floppy disk can be downloaded from the PC to an indicator. This procedure is useful when a number of indicators with similar configurations are set up or when an indicator is replaced.

To download configuration data, connect the PC to the EDP port as described in Section 5.2.1. Place the indicator in setup mode and use the PC communications software to send the saved configuration data to the indicator. When transfer is complete, calibrate the indicator as described in Section 4.0 on page 21.

NOTE: Calibration settings are included in the configuration data downloaded to the indicator. If the receiving indicator is a direct replacement for another IQ plus 390-DC and the attached scale is not changed, recalibration is not required.

6.0 Counting Operations

The IQ plus 390-DC provides a piece count mode that allows the indicator to serve as a portable counting scale. In piece count mode, the indicator display shows the number of parts on the scale rather than the weight of those parts.

NOTE: *Legal-for-trade applications require product to be sold by weight rather than an equivalent parts count. Operator access to piece count mode is disabled when the indicator is shipped from the factory.*

To enable operator access to piece count mode, set the ACCESS parameter to ENABLE (COUNT submenu on the PROGRAM menu) or send the CNTMOD=ENABLE EDP command.

Piece count mode has two submodes:

- Count display mode displays the current parts count and allows ticket printing using the CFMT print format.
- Sample acquisition mode is used to calibrate the indicator for parts counting.

Count Display Mode

Piece count mode is entered by pressing the MODE (GROSS/NET) key from normal weighing mode. In count display mode, the display shows the number of parts rather than weight, the arrow annunciator at the right side of the LCD display points to piece count (PC), and pressing the PRINT key sends the CFMT print format data string to the serial port.

If a sample weight has not yet been acquired, the indicator switches automatically to sample acquisition mode, described below.

Sample Acquisition Mode

Sample acquisition mode is used to select the sample quantity and calibrate the indicator for the parts being counted.

To set a new sample weight, do the following:

1. Place empty parts container on scale. Wait for standstill, then press TARE to acquire the tare weight of the container.
2. Press MODE to enter piece count mode.
3. From count display mode, press the SAMPLE (UNITS) key to enter sample acquisition mode.
4. The indicator display shows the message *Addnnn*, where *nnn* is the sample quantity to be placed on the scale. Add the number of parts shown or choose a different sample size by pressing the SAMPLE key to scroll through the selectable sample quantities (5, 10, 20, 50, 100).
5. Once the sample quantity is on the scale, press ENTER to calibrate the indicator for counting the new parts. The indicator display shows the message *-CNT-* as it acquires the sample weight, then switches to count display mode and shows the part quantity.

If the weight of the sample quantity is insufficient for piece counting, the indicator automatically requests the next higher sample quantity by showing the *Addnnn* message again. If the sample quantity is at maximum (100) and the sample weight is still not sufficient, the indicator shows the message *CNTERR*.

To view gross and net weight of parts, press MODE to switch from count display mode to normal weighing mode.

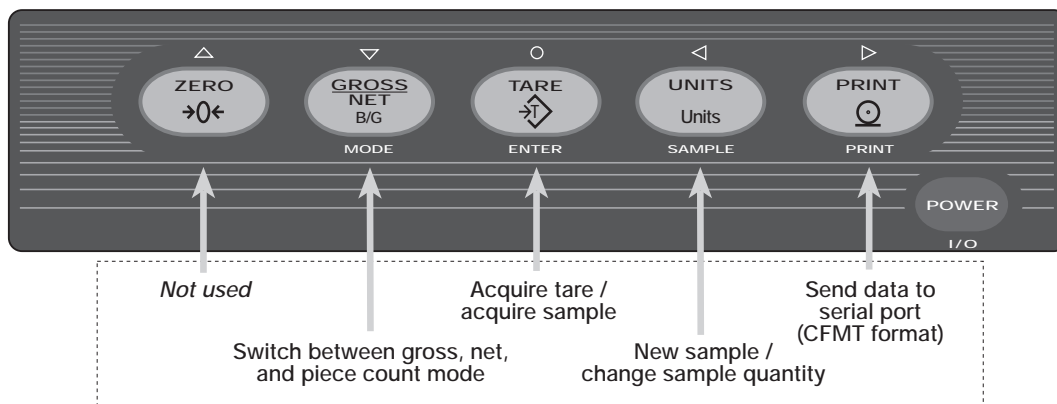

COUNTING MODE KEY FUNCTIONS

Figure 6-1. Front Panel Key Functions in Piece Count Mode

7.0 Print Formatting

The IQ plus 390-DC provides three print formats, GFMT, NFMT, and CFMT that determine the format of the printed output when the PRINT key is pressed or when a KPRINT EDP command is received. If no tare has been entered, the GFMT print format is used; if a tare has been entered, NFMT is used; in counting mode, CFMT is used.

Each print format can be customized to include up to 300 characters of information, such as company name and address, on printed tickets. You can use the indicator front panel (PFORMAT menu), EDP commands, or the Revolution™ Scaleware configuration utility to customize the print formats.

7.1 Print Formatting Commands

Table 7-1 lists commands you can use to format the gross and net print formats. Commands included in the format strings must be enclosed between < and > delimiters. Any characters outside of the delimiters are printed as text on the ticket. Text characters can include any ASCII character that can be printed by the output device.

Command	Description
<G>	Gross weight in displayed units
<G2>	Gross weight in non-displayed units
<N>	Net weight in displayed units
<N2>	Net weight in non-displayed units
<T>	Tare weight in displayed units
<T2>	Tare weight in non-displayed units
<C>	Current piece count
<ID>	Unit identifier
<CN>	Consecutive number
<NLnn>	New line (nn = number of termination (<CR/LF> or <CR>) characters)*
<SPnn>	Space (nn = number of spaces)*
<SU>	Toggle weight data format (formatted/unformatted)**
Gross, net, and tare weights are 10 digits in length, including sign, followed by a space and a two-digit units identifier. Total field length with units identifier is 13 characters.	
ID and consecutive number (CN) fields are 1–6 characters in length, as required.	
* If nn is not specified, 1 is assumed. Value must be in the range 1–99.	

Table 7-1. Print Format Commands

Command	Description
**	After receiving an SU command, the indicator sends unformatted data until the next SU command is received. Unformatted data omits decimal points, leading and trailing characters.

Table 7-1. Print Format Commands

The default GFMT and NFMT print formats use only the new line (<NL>) command and the commands for gross, net, and tare weights in displayed units (<G>, <N>, and <T>).

The default IQ plus 390-DC print formats are shown in Table 7-2:

Format	Default Format String	Sample Output
GFMT	<G> GROSS<NL>	2046.81 LB GROSS
NFMT	<G> GROSS<NL> <T> TARE<NL> <N> NET<NL>	4053.1 LB GROSS 15.6 LB TARE 4037.5 LB NET
CFMT	<C> PIECES<NL>	512 PC PIECES

Table 7-2. Default Print Formats

NOTES:

- The <G2>, <N2>, and <T2> commands listed in Table 7-1 print the gross, net, and tare weights in non-displayed units—that is, in the units *not* currently displayed on the indicator.
- ID numbers included in the print format string (<ID> command) must be set using the UID EDP command.
- The 300-character limit of each print format string includes the output field length of the print formatting commands, not the command length. For example, if the indicator is configured to show a decimal point, the <G> command generates an output field of 13 characters: the 10-character weight value (including decimal point), one space, and a two-digit units identifier.

7.2 Customizing Print Formats

The following sections describe procedures for customizing the GFMT, NFMT, and CFMT formats using the EDP port, the front panel (PFORMAT menu), and the Revolution Scaleware configuration utility.

7.2.1 Using the EDP Port

With a personal computer, terminal, or remote keyboard attached to the IQ plus 390-DC EDP port, you can use the EDP command set to customize the print format strings.

To view the current setting of a format string, type the name of the string (GFMT, NFMT, or CFMT) and press ENTER. For example, to check the current configuration of the GFMT format, type GFMT and press ENTER. The indicator responds by sending the current configuration for the gross format:

```
GFMT=<G> GROSS<NL>
```

To change the format, use the GFMT, NFMT, or CFMT EDP command followed by an equals sign (=) and the modified print format string. For example, to add the name and address of a company to the gross format, you could send the following EDP command:

```
GFMT=MLC SHIPPING<NL>1357 WEST  
HOWARD ROAD<NL>BIGTOWN<NL2><G>  
GROSS<NL>
```

A ticket printed using this format might look like the following:

```
MLC SHIPPING  
1357 WEST HOWARD ROAD  
BIGTOWN
```

```
27862 LB GROSS
```

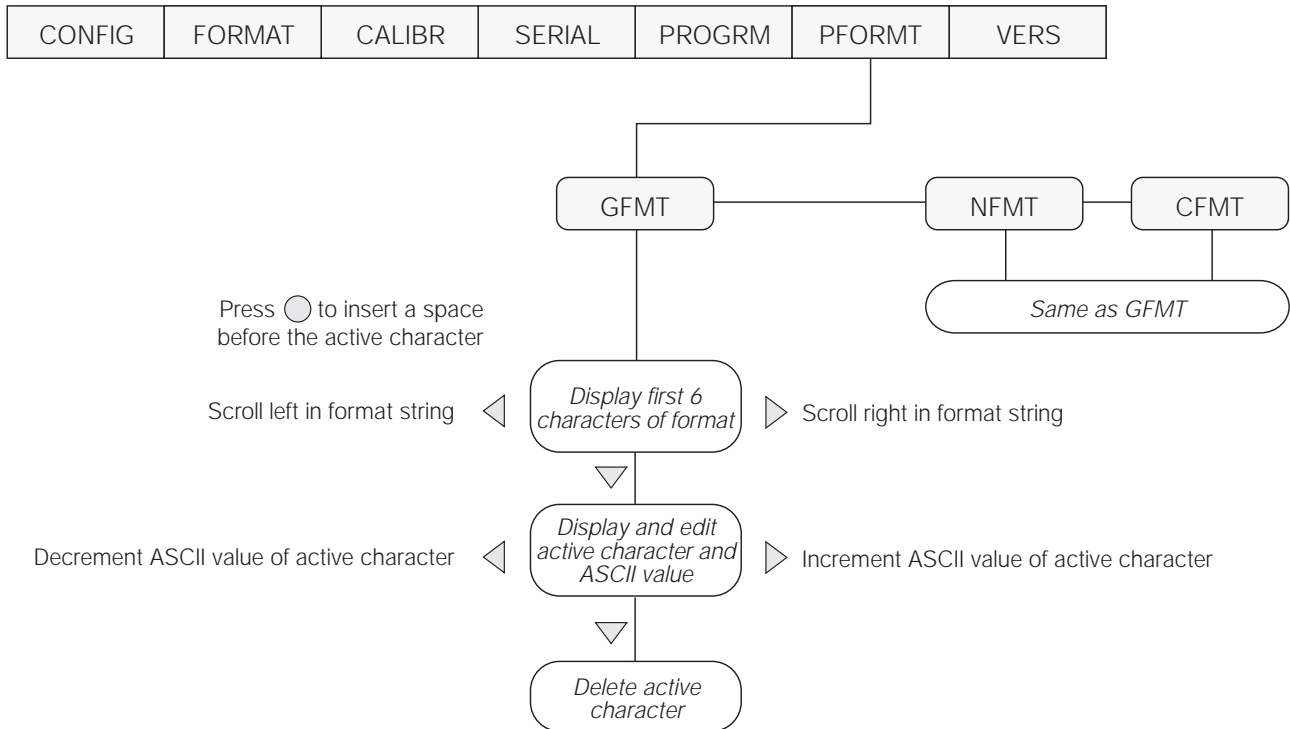

Figure 7-1. PFORMAT Menu, Showing Alphanumeric Character Entry Procedure

7.2.2 Using the Front Panel

If you have no access to equipment for communication through the EDP port or are working at a site where such equipment cannot be used, you can use the PFORMAT menu (see Figure 7-1) to customize the print formats.

Using the PFORMAT menu, you can edit the print format strings by changing the decimal values of the ASCII characters in the format string.

NOTE: Lower-case letters and some special characters cannot be displayed on the IQ plus 390-DC front panel (see the ASCII character chart on page 32) and are shown as blanks. The IQ plus 390-DC can send or receive any ASCII character; the character printed depends on the particular ASCII character set implemented for the receiving device.

7.2.3 Using Revolution Scaleware

The Revolution Scaleware configuration utility provides a print formatting grid with a tool bar. The grid allows you to construct the print format without the formatting commands (<NL> and <SP>) required by the front panel or EDP command methods. Using Revolution, you can type text directly into the grid, then select weight value fields from the tool bar and place them where you want them to appear on the printed ticket.

Figure 7-2 shows an example of the Revolution Scaleware print formatting grid.

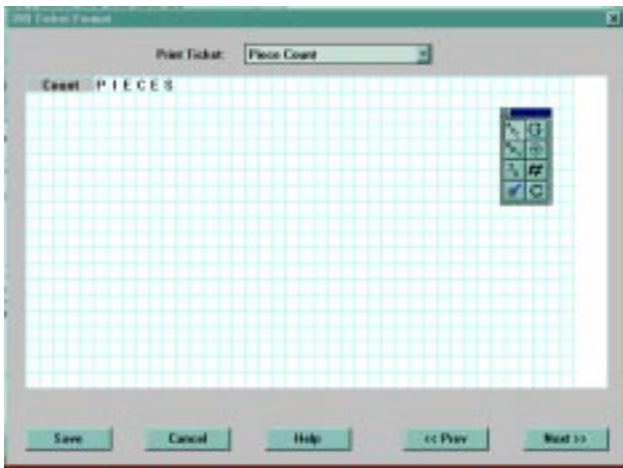

Figure 7-2. Revolution Scaleware Print Format Grid

8.0 Appendix

8.1 Error Messages

The IQ plus 390-DC provides a number of front panel error messages to assist in problem diagnosis. Table 8-1 lists these messages and their meanings.

Error Message	Description	Solution
ADCERR	A/D not responding	Call Rice Lake Weighing Systems (RLWS) Service.
ADCKSM	A/D coefficient checksum error	
CFCKSM	Configuration checksum error	Use TEST menu to perform DEFLT (restore defaults) procedure, then recalibrate load cells.
CNTERR	Count error; insufficient sample size	Call RLWS Service.
DSPERR	Display error	
EEPERR	EEPROM error	
LCCKSM	Load cell calibration checksum error	Recalibrate load cells.
LCPERR	Load cell power failed	Call RLWS Service.
PFCKSM	Print format checksum error	Check print formats for errors.
RAMERR	RAM test failed	Call RLWS Service.
VIREE	EEPROM error	Use TEST menu to perform DEFLT (restore defaults) procedure, then recalibrate load cells and reconfigure indicator.
-----	Overflow error	Weight value too large (> 999999) to be displayed or gross value exceeds overload limit. Check configuration.
_____	A/D underrange	Weight value too small (< -99999) to be displayed or A/D reading < -2.5 mV. Check scale for binding or damage.
STNDBY	Standby mode	Press any key to return to operating mode.

Table 8-1. IQ plus 390-DC Error Messages

8.2 Continuous Output (Stream) Format

Figure 8-1 shows the continuous output format sent to the IQ plus 390-DC serial port when the STREAM parameter (SERIAL menu) is set to either LFT or INDUST.

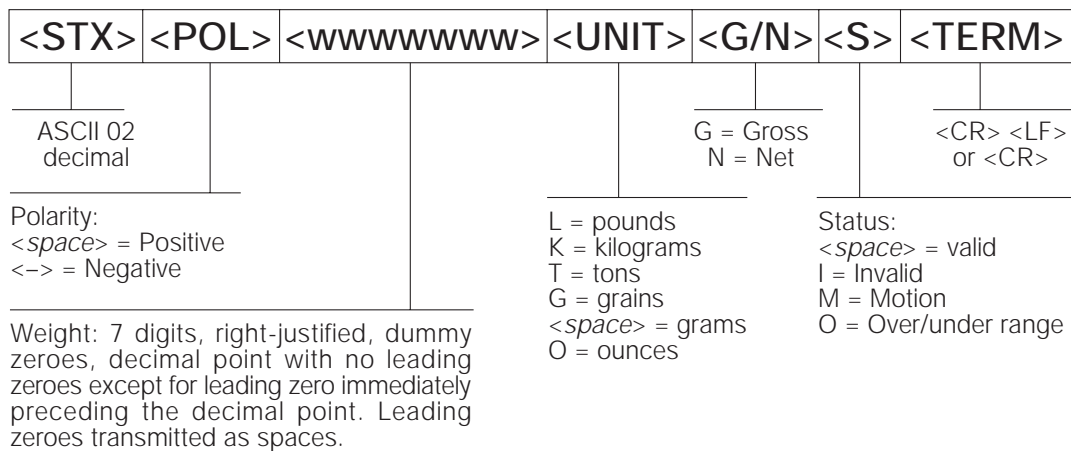

Figure 8-1. Continuous Output Data Format

8.3 ASCII Character Chart

Use the decimal values for ASCII characters listed in Tables 8-2 and 8-3 when specifying print format strings on the IQ plus 390-DC PFORMT menu. The actual character printed depends on the character mapping used by the output device. The IQ plus 390-DC can send or receive any ASCII character value (decimal 0–255), but the indicator display is limited to the set described in Section 8.4 on page 34.

Control	ASCII	Dec	Hex	ASCII	Dec	Hex	ASCII	Dec	Hex	ASCII	Dec	Hex
Ctrl-@	NUL	00	00	space	32	20	@	64	40	`	96	60
Ctrl-A	SOH	01	01	!	33	21	A	65	41	a	97	61
Ctrl-B	STX	02	02	“	34	22	B	66	42	b	98	62
Ctrl-C	ETX	03	03	#	35	23	C	67	43	c	99	63
Ctrl-D	EOT	04	04	\$	36	24	D	68	44	d	100	64
Ctrl-E	ENQ	05	05	%	37	25	E	69	45	e	101	65
Ctrl-F	ACK	06	06	&	38	26	F	70	46	f	102	66
Ctrl-G	BEL	07	07	,	39	27	G	71	47	g	103	67
Ctrl-H	BS	08	08	(40	28	H	72	48	h	104	68
Ctrl-I	HT	09	09)	41	29	I	73	49	i	105	69
Ctrl-J	LF	10	0A	*	42	2A	J	74	4A	j	106	6A
Ctrl-K	VT	11	0B	+	43	2B	K	75	4B	k	107	6B
Ctrl-L	FF	12	0C	,	44	2C	L	76	4C	l	108	6C
Ctrl-M	CR	13	0D	-	45	2D	M	77	4D	m	109	6D
Ctrl-N	SO	14	0E	.	46	2E	N	78	4E	n	110	6E
Ctrl-O	SI	15	0F	/	47	2F	O	79	4F	o	111	6F
Ctrl-P	DLE	16	10	0	48	30	P	80	50	p	112	70
Ctrl-Q	DC1	17	11	1	49	31	Q	81	51	q	113	71
Ctrl-R	DC2	18	12	2	50	32	R	82	52	r	114	72
Ctrl-S	DC3	19	13	3	51	33	S	83	53	s	115	73
Ctrl-T	DC4	20	14	4	52	34	T	84	54	t	116	74
Ctrl-U	NAK	21	15	5	53	35	U	85	55	u	117	75
Ctrl-V	SYN	22	16	6	54	36	V	86	56	v	118	76
Ctrl-W	ETB	23	17	7	55	37	W	87	57	w	119	77
Ctrl-X	CAN	24	18	8	56	38	X	88	58	x	120	78
Ctrl-Y	EM	25	19	9	57	39	Y	89	59	y	121	79
Ctrl-Z	SUB	26	1A	:	58	3A	Z	90	5A	z	122	7A
Ctrl-[ESC	27	1B	;	59	3B	[91	5B	{	123	7B
Ctrl-\	FS	28	1C	<	60	3C	\	92	5C		124	7C
Ctrl-]	GS	29	1D	=	61	3D]	93	5D	}	125	7D
Ctrl-^	RS	30	1E	>	62	3E	^	94	5E	~	126	7E
Ctrl- _~	US	31	1F	?	63	3F	_	95	5F	DEL	127	7F

Table 8-2. ASCII Character Chart (Part 1)

ASCII	Dec	Hex	ASCII	Dec	Hex	ASCII	Dec	Hex	ASCII	Dec	Hex
Ç	128	80	á	160	A0		192	C0	α	224	E0
ü	129	81	í	161	A1		193	C1	β	225	E1
é	130	82	ó	162	A2		194	C2	Γ	226	E2
â	131	83	ú	163	A3		195	C3	π	227	E3
ä	132	84	ñ	164	A4		196	C4	Σ	228	E4
à	133	85	Ñ	165	A5		197	C5	σ	229	E5
â	134	86	ª	166	A6		198	C6	μ	230	E6
ç	135	87	º	167	A7		199	C7	τ	231	E7
ê	136	88	¿	168	A8		200	C8	Φ	232	E8
ë	137	89		169	A9		201	C9	Θ	233	E9
è	138	8A	¬	170	AA		202	CA	Ω	234	EA
ï	139	8B	½	171	AB		203	CB	δ	235	EB
î	140	8C	¼	172	AC		204	CC	∞	236	EC
ì	141	8D	¡	173	AD		205	CD	φ	237	ED
Ä	142	8E	«	174	AE		206	CE	€	238	EE
Å	143	8F	»	175	AF		207	CF	∩	239	EF
É	144	90		176	B0		208	D0	≡	240	F0
æ	145	91		177	B1		209	D1	±	241	F1
Æ	146	92		178	B2		210	D2	≥	242	F2
ô	147	93		179	B3		211	D3	≤	243	F3
ö	148	94		180	B4		212	D4	∫	244	F4
ò	149	95		181	B5		213	D5	∫	245	F5
û	150	96		182	B6		214	D6	÷	246	F6
ù	151	97		183	B7		215	D7	≈	247	F7
ÿ	152	98		184	B8		216	D8	°	248	F8
Ö	153	99		185	B9		217	D9	•	249	F9
Ü	154	9A		186	BA		218	DA		250	FA
ç	155	9B		187	BB		219	DB		251	FB
£	156	9C		188	BC		220	DC		252	FC
¥	157	9D		189	BD		221	DD	²	253	FD
Pts	158	9E		190	BE		222	DE		254	FE
f	159	9F		191	BF		223	DF		255	FF

Table 8-3. ASCII Character Chart (Part 2)

8.4 Front Panel Display Characters

Figure 8-2 shows the 7-segment LCD character set used to display alphanumeric characters on the IQ plus 390-DC front panel.

!	-	9	Ee	Qq]
"	.	:	Ff	Rr	^
#	/	;	Gg	Ss	_
\$	0	<	Hh	Tt	`
%	1	=	li	Uu	{
&	2	>	Jj	Vv	
'	3	?	Kk	Ww	}
(4	@	Ll	Xx	~
)	5	Aa	Mm	Yy	
*	6	Bb	Nn	Zz	
+	7	Cc	Oo	[
,	8	Dd	Pp	\	

Figure 8-2. IQ plus 390-DC Display Characters

8.5 Conversion Factors for Secondary Units

The IQ plus 390-DC has the capability to mathematically convert a weight into many different types of units and instantly display those results with a press of the UNITS key. Secondary units can be specified on the FORMAT menu using the SECNDR parameter, or by using EDP commands.

- To configure secondary units using the front panel menus, use Table 8-4 to find the conversion multiplier for the MULT parameter. For example, if the primary unit is pounds and the secondary unit is short tons, set the MULT parameter to 0.00050, then press \odot to save the value.

For secondary units with a conversion factor of 10 or more, enter the value as described above without regard to decimal position, then use the \triangleleft or \triangleright key to move the decimal point to the correct position. Press \odot a second time to save the value.

For example, if the primary unit is ounces and the secondary unit is grams, the conversion factor shown in Table 8-4 is 28.3495. To enter this value using the menus, first enter 2.83495 for the MULT parameter, then use the left and right front panel keys to adjust the decimal point to 28.3495. Press \odot again to save the value and exit the MULT parameter.

- To configure secondary units using EDP commands, use the Table 8-4 to find the conversion multiplier for the SEC.MULT command. For example, if the primary unit is pounds and the secondary unit is short tons, send the EDP command SEC.MULT=0.0005<CR> to set the multiplier for the secondary units.
- Long tons and grains units listed in Table 8-4 cannot be directly specified as primary or secondary units on the IQ plus 390-DC indicator. For these or other unlisted units of weight, specify NONE on the UNITS parameter.

NOTE: Ensure that the secondary decimal point position is set appropriately for the scale capacity in the secondary units. If the converted value requires more digits than are available, the indicator will display an overflow message (*OVERFL*).

For example, if the primary units are short tons, secondary units are pounds, and the secondary decimal point is set to 8888.88, the indicator will overflow if 5 tons or more are applied to the scale. With 5 tons applied, and a conversion factor of 2000, the secondary units display needs five digits to the left of the decimal point to display the 10000 lb secondary units value.

Primary Unit	<i>x Multiplier</i>	Secondary Unit
grains	0.06480	grams
	0.00229	ounces
	0.00014	pounds
	0.00006	kilograms
ounces	437.500	grains
	28.3495	grams
	0.06250	pounds
	0.02835	kilograms
pounds	7000.00	grains
	453.592	grams
	16.0000	ounces
	0.45359	kilograms
	0.00050	short tons
	0.00045	long tons
	0.00045	metric tons
short tons	2000.00	pounds
	907.185	kilograms
	0.89286	long tons
	0.90718	metric tons
grams	15.4324	grains
	0.03527	ounces
	0.00220	pounds
	0.00100	kilograms
kilograms	15432.4	grains
	35.2740	ounces
	1000.00	grams
	2.20462	pounds
	0.00110	short tons
	0.00098	long tons
	0.00100	metric tons
metric tons	2204.62	pounds
	1000.00	kilograms
	1.10231	short tons
	0.98421	long tons
long tons	2240.00	pounds
	1016.05	kilograms
	1.12000	short tons
	1.01605	metric tons

Table 8-4. Conversion Factors

8.6 Digital Filtering

The IQ plus 390-DC uses averaged digital filtering to reduce the effect of vibration on weight readings. Adjustable threshold and sensitivity functions allow quick settling by suspending filter averaging, allowing the weight reading to jump to the new value. Figure 8-3 shows the digital filter parameters on the CONFIG menu.

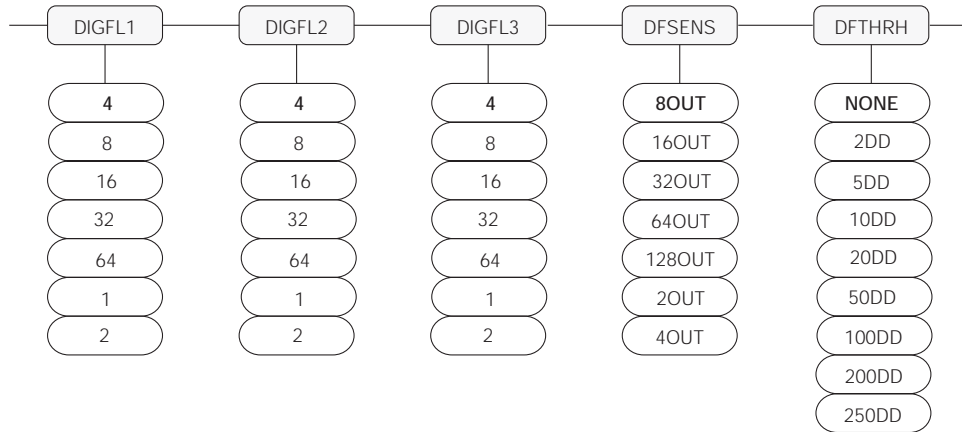

Figure 8-3. Digital Filtering Parameters on the Configuration (CONFIG) Menu

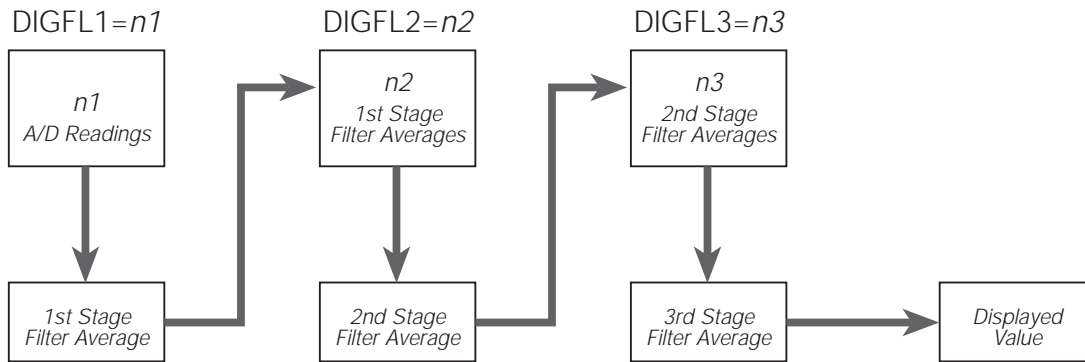

Figure 8-4. Flow Diagram for IQ plus 390-DC Digital Filters

8.6.1 DIGFLx Parameters

The first three digital filtering parameters, DIGFL1, DIGFL2, and DIGFL3, are configurable filter stages that control the effect of a single A/D reading on the displayed weight. The value assigned to each parameter sets the number of readings received from the preceding filter stage before averaging (see Figure 8-4).

The overall filtering effect can be expressed by multiplying the values assigned to the three filter stages:

$$DIGFL1 \times DIGFL2 \times DIGFL3$$

For example, if the filters are configured as DIGFL1=4, DIGFL2=8, DIGFL3=8, the overall filtering effect is 256 (4 x 8 x 8). With this configuration, each A/D reading has a 1-in-256 effect on the displayed weight value. Setting the filters to 1 effectively disables digital filtering (1 x 1 x 1 = 1).

8.6.2 DFESENS and DFTHR Parameters

The three digital filters can be used by themselves to eliminate vibration effects, but heavy filtering also increases settling time. The DFESENS (digital filter sensitivity) and DFTHR (digital filter threshold) parameters can be used to temporarily override filter averaging and improve settling time:

- DFESENS specifies the number of consecutive scale readings that must fall outside the filter threshold (DFTHR) before digital filtering is suspended.
- DFTHR sets a threshold value, in display divisions. When a specified number of consecutive scale readings (DFSENS) fall outside of this threshold, digital filtering is suspended.

8.6.3 Setting the Digital Filter Parameters

Fine-tuning the digital filter parameters greatly improves indicator performance in heavy-vibration environments. Use the following procedure to determine vibration effects on the scale and optimize the digital filtering configuration.

1. In setup mode, set all three digital filters (DIGFL1, DIGFL2, DIGFL3) to 1. Set DFTHRH to NONE. Return indicator to normal mode.
2. Remove all weight from the scale, then watch the indicator display to determine the magnitude of vibration effects on the scale. Record the weight below which all but a few readings fall. This value is used to calculate the DFTHRH parameter value in Step 4.

For example, if a heavy-capacity scale produces vibration-related readings of up to 50 lb, with occasional spikes to 75 lb, record 50 lb as the threshold weight value.

3. Place the indicator in setup mode and set the digital filters (DIGFL x) to eliminate the

vibration effects on the scale. (Leave DFTHRH set to NONE.) Reconfigure as necessary to find the lowest effective values for the DIGFL x parameters.

4. With optimum values assigned to the DIGFL x parameters, calculate the DFTHRH parameter value by converting the weight value recorded in Step 2 to display divisions:
 $threshold_weight_value / DSPDIV$

In the example in Step 2, with a threshold weight value of 50 lb and a display division value of 5D: $50 / 5D = 10$. DFTHRH should be set to 10DD for this example.

5. Finally, set the DFSENS parameter high enough to ignore transient peaks. Longer transients (typically caused by lower vibration frequencies) will cause more consecutive out-of-band readings, so DFSENS should be set higher to counter low frequency transients.

Reconfigure as necessary to find the lowest effective value for the DFSENS parameter.

8.7 Test Mode

In addition to normal and setup modes, test mode provides a number of diagnostic functions for the IQ plus 390-DC, including:

- Display raw A/D count
- Set A/D offset and gain calibration
- Reset configuration parameters to default values
- Print indicator configuration

To enter test mode, press and hold the setup switch until the front panel display shows the word *TEST*. After about three seconds, the test mode display automatically shifts to the first test menu function, A/DTST.



Caution

A/D calibration functions, ADOFFS and ADGAIN, must be used only by qualified service personnel, and only after replacing A/D converter components. Improper A/D calibration may render the indicator unusable.

Figure 8-5 shows the Test Menu structure; Figure 8-6 shows the front panel key functions in test mode. Note that, because the Test Menu functions are all on a single menu level, the GROSS/NET (∇) key has no function. Press the ZERO (Δ) key to exit test mode.

Table 8-5 on page 38 summarizes the test menu functions.



Figure 8-5. Test Menu

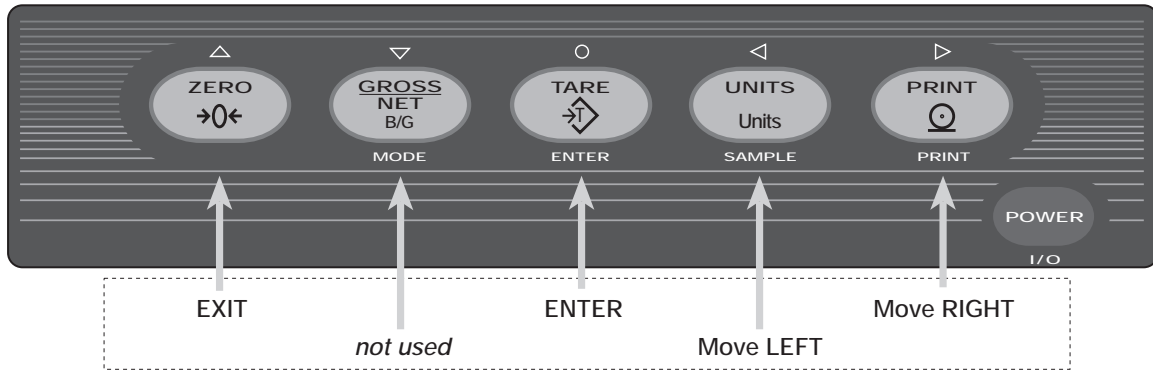

TEST MODE KEY FUNCTIONS

Figure 8-6. Front Panel Key Functions in Test Mode

TEST Menu	
Function	Description
A/DTST	Display A/D test Press and hold Enter key to display raw count from A/D converter.
ADOFFS	A/D offset calibration (-0.5 mv/V) Read Caution! statement on page 37 before using this function. Press and hold the setup switch, then press the Enter key to perform offset calibration.
ADGAIN	A/D gain calibration (+4.5 mv/V) Read Caution! statement on page 37 before using this function. Press and hold the setup switch, then press the Enter key to perform gain calibration.
DEFLT	Default parameters Press and hold the setup switch, then press the Enter key to reset configuration and calibration parameters to factory default values. This function is equivalent to using the RESETCONFIGURATION EDP command followed by the RS (reset) EDP command.
PRTCFG	Print configuration Press the Enter key to print the indicator configuration to the serial port. This function is equivalent to using the DUMPALL EDP command.

Table 8-5. Test Menu Functions

8.8 Specifications

Power

Power	9 VDC, provided by 6 x "C" cell alkaline batteries or AC adapter (9VDC, 300 mA, center-positive output connector)
Power Consumption	100 mA (using 4 x 350 Ω load cells)
Fusing	1 x 250 mA TR5 subminiature fuse Wickmann Time-Lag 19374 Series UL Listed, CSA Certified

Analog Specifications

Full Scale Input Signal	Up to 17 mV
Excitation Voltage	5 \pm 0.25 VDC, 4 x 350 Ω or 8 x 700 Ω load cells
Sense Amplifier	Differential amplifier with 4- and 6-wire sensing
Analog Signal Input Range	-2.5 mV/V – 22.5 mV/V
Analog Signal Sensitivity	0.3 μ V/graduation minimum, 1.5 μ V/grad recommended
Input Impedance	200 M Ω , typical
Noise (ref to input)	0.3 μ V p-p with digital filters at 4-4-4
Internal Resolution	2 ²⁰ (approx. 1 000 000) counts
Display Resolution	999 999 dd
Measurement Rate	15 measurements/sec, nominal
Input Sensitivity	155 nV per internal count
System Linearity	Within 0.01% of full scale
Zero Stability	155 nV/ $^{\circ}$ C, maximum
Span Stability	4.0 ppm/ $^{\circ}$ C, maximum
Calibration Method	Software, constants stored in EEPROM
Common Mode Voltage	2.5 \pm .25 VDC
Common Mode Rejection	140 dB minimum @ 50 or 60 Hz
Normal Mode Rejection	90 dB minimum @ 50 or 60 Hz
Input Overload	\pm 12 V continuous, static discharge protected
RFI Protection	Signal, excitation, and sense lines protected by capacitor bypass

Digital Specifications

Microcomputer	Phillips P51XAG30 microcontroller @ 12.288 MHz
Digital Filters	3 filters, software selectable

Serial Communications

EDP/Printer Port	Full duplex RS-232 19 200, 9600, 4800, 2400, 1200, 600, 300 bps; 8 data bits, no parity, or 7 data bits, even or odd parity
------------------	--

Operator Interface

Display	6-digit LCD display: 7-segment, 1.0 in (25 mm) digits
Additional Symbols	Annunciators for gross, net, standstill, center of zero, tare, low battery. \triangleright annunciators for units (lb/kg), piece count mode (PC). Adhesive labels provided for units other than lb and kg.
Keyboard	6-key flat membrane panel

Environmental

Operating Temperature	-10 to +40 $^{\circ}$ C (legal); -10 to +50 $^{\circ}$ C (industrial)
Storage Temperature	-25 to +70 $^{\circ}$ C
Humidity	0–95% relative humidity
Altitude	2000 m (6500 ft) maximum

Enclosure

Enclosure Dimensions (including battery compartment cover)	9.0 in x 5.5 in x 4.1 in 23 cm x 14 cm x 10.4 cm
--	---

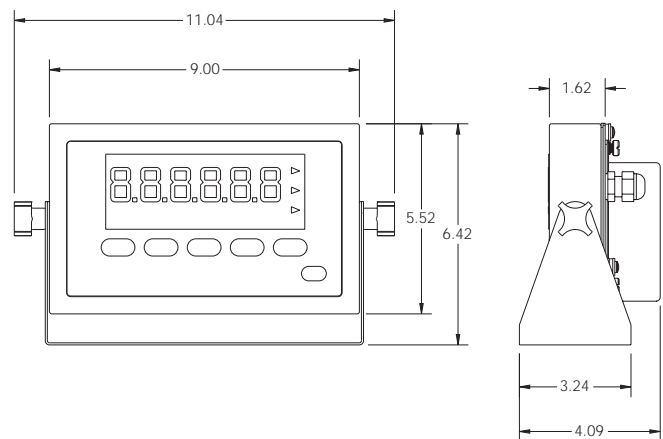

Weight	1.42 Kg (3.13 lb)
Rating/Material	NEMA 4X/IP66, stainless steel

Certifications and Approvals



NTEP

CoC Number	98-203
Accuracy Class	III/III L n_{max} : 10 000

IQ plus 390-DC Limited Warranty

Rice Lake Weighing Systems (RLWS) warrants that all RLWS equipment and systems properly installed by a Distributor or Original Equipment Manufacturer (OEM) will operate per written specifications as confirmed by the Distributor/OEM and accepted by RLWS. All systems and components are warranted against defects in materials and workmanship for two years.

RLWS warrants that the equipment sold hereunder will conform to the current written specifications authorized by RLWS. RLWS warrants the equipment against faulty workmanship and defective materials. If any equipment fails to conform to these warranties, RLWS will, at its option, repair or replace such goods returned within the warranty period subject to the following conditions:

- Upon discovery by Buyer of such nonconformity, RLWS will be given prompt written notice with a detailed explanation of the alleged deficiencies.
- Individual electronic components returned to RLWS for warranty purposes must be packaged to prevent electrostatic discharge (ESD) damage in shipment. Packaging requirements are listed in a publication, *Protecting Your Components From Static Damage in Shipment*, available from RLWS Equipment Return Department.
- Examination of such equipment by RLWS confirms that the nonconformity actually exists, and was not caused by accident, misuse, neglect, alteration, improper installation, improper repair or improper testing; RLWS shall be the sole judge of all alleged non-conformities.
- Such equipment has not been modified, altered, or changed by any person other than RLWS or its duly authorized repair agents.
- RLWS will have a reasonable time to repair or replace the defective equipment. Buyer is responsible for shipping charges both ways.
- In no event will RLWS be responsible for travel time or on-location repairs, including assembly or disassembly of equipment, nor will RLWS be liable for the cost of any repairs made by others.

THESE WARRANTIES EXCLUDE ALL OTHER WARRANTIES, EXPRESSED OR IMPLIED, INCLUDING WITHOUT LIMITATION WARRANTIES OF MERCHANTABILITY OR FITNESS FOR A PARTICULAR PURPOSE. NEITHER RLWS NOR DISTRIBUTOR WILL, IN ANY EVENT, BE LIABLE FOR INCIDENTAL OR CONSEQUENTIAL DAMAGES.

RLWS AND BUYER AGREE THAT RLWS'S SOLE AND EXCLUSIVE LIABILITY HEREUNDER IS LIMITED TO REPAIR OR REPLACEMENT OF SUCH GOODS. IN ACCEPTING THIS WARRANTY, THE BUYER WAIVES ANY AND ALL OTHER CLAIMS TO WARRANTY.

SHOULD THE SELLER BE OTHER THAN RLWS, THE BUYER AGREES TO LOOK ONLY TO THE SELLER FOR WARRANTY CLAIMS.

NO TERMS, CONDITIONS, UNDERSTANDING, OR AGREEMENTS PURPORTING TO MODIFY THE TERMS OF THIS WARRANTY SHALL HAVE ANY LEGAL EFFECT UNLESS MADE IN WRITING AND SIGNED BY A CORPORATE OFFICER OF RLWS AND THE BUYER.

© 1999 Rice Lake Weighing Systems, Inc. Rice Lake, WI USA. All Rights Reserved.

RICE LAKE WEIGHING SYSTEMS • 230 WEST COLEMAN STREET • RICE LAKE, WISCONSIN 54868 • USA