

IQ plus[®] 710

Digital Weight Indicator

Version 1.4

Installation Manual



RICE LAKE WEIGHING SYSTEMS
Industrial Solutions on a Global Scale[®]



Contents

About This Manual	1
1.0 Introduction.....	1
1.1 Operating Modes	1
1.2 Front Panel Display	2
1.3 Indicator Operations.....	3
1.3.1 Toggle Gross/Net Mode.....	3
1.3.2 Toggle Units.....	3
1.3.3 Zero Scale.....	3
1.3.4 Acquire Tare.....	3
1.3.5 Remove Stored Tare Value.....	3
1.3.6 Print Ticket.....	3
1.3.7 Display or Change Time and Date	3
1.3.8 Display or Change Setpoint Value	3
1.3.9 Turn Setpoint On or Off	3
1.3.10 Display or Clear Accumulator	3
2.0 Installation.....	4
2.1 Unpacking and Assembly.....	4
2.2 Enclosure Disassembly.....	4
2.3 Cable Connections.....	4
2.3.1 Load Cells.....	5
2.3.2 Serial Communications.....	6
2.3.3 Digital I/O	6
2.3.4 Analog Output.....	6
2.4 Analog Output Module Installation	6
2.5 Enclosure Reassembly	7
2.6 Board Removal	7
2.7 Replacement Parts.....	7
3.0 Configuration.....	13
3.1 Configuration Methods	13
3.1.1 Revolution Scaleware Configuration	13
3.1.2 EDP Command Configuration	13
3.1.3 Front Panel Configuration.....	14
3.2 Menu Structures and Parameter Descriptions	15
3.2.1 Configuration Menu.....	16
3.2.2 Format Menu.....	19
3.2.3 Calibration Menu	21
3.2.4 Serial Menu	22
3.2.5 Program Menu	24
3.2.6 Print Format Menu	26
3.2.7 Setpoints Menu.....	27
3.2.8 Digital Input Menu	31
3.2.9 Analog Output Menu	32
3.2.10 Version Menu.....	32
4.0 Calibration.....	33
4.1 Front Panel Calibration	33
4.2 EDP Command Calibration.....	34
4.3 Revolution™ Scaleware Calibration.....	35

5.0	EDP Commands	36
5.1	The EDP Command Set	36
5.1.1	Key Press Commands.....	36
5.1.2	Reporting Commands.....	37
5.1.3	The RESETCONFIGURATION Command.....	37
5.1.4	Parameter Setting Commands.....	37
5.1.5	Normal Mode Commands.....	41
5.2	Saving and Transferring Data	42
5.2.1	Saving and Printing Indicator Data.....	42
5.2.2	Downloading Configuration Data from PC to Indicator.....	42
6.0	Print Formatting	43
6.1	Print Formatting Commands	43
6.2	Default Ticket Formats	44
6.3	Customizing Print Formats	45
6.3.1	Using the EDP Port	45
6.3.2	Using the Front Panel.....	45
6.3.3	Using Revolution Scaleware	45
7.0	Truck Modes	47
7.1	Using the Truck Modes	47
7.1.1	Modes 1 and 2.....	48
7.1.2	Modes 3, 4, 5, and 6.....	48
8.0	Setpoints	49
8.1	Batch and Continuous Setpoints.....	49
8.2	Batching Examples	51
8.2.1	Example 1.....	51
8.2.2	Example 2.....	52
9.0	Macro Programming	53
9.1	Using the Macro Submenu.....	53
9.2	Macro Programming Examples	55
9.2.1	Example 1.....	55
9.2.2	Example 2.....	56
9.2.3	Example 3.....	58
10.0	Appendix	60
10.1	Error Messages.....	60
10.1.1	Displayed Error Messages.....	60
10.1.2	Using the XE EDP Command	60
10.2	Status Messages.....	61
10.3	Data Formats	62
10.3.1	Continuous Output Serial Data Format	62
10.3.2	Demand Output Serial Data Format.....	62
10.3.3	RS-485 Data Formats	62
10.4	ASCII Character Chart.....	63
10.5	Digital Filtering.....	65
10.5.1	DFSENS and DFTHRH Parameters	65
10.5.2	Setting the Digital Filter Parameters.....	65
10.6	Conversion Factors for Secondary Units.....	65
10.7	Analog Output Calibration	67
10.8	Test Mode.....	67
10.9	Software Upgrade Instructions	69
10.10	Software Revision History.....	69
10.11	Specifications.....	70
IQ plus 710	Limited Warranty	71

About This Manual

This manual is intended for use by service technicians responsible for installing and servicing IQ plus® 710 digital weight indicators.

This manual applies to indicators using Version 1.4 of the IQ plus 710 software. See Section 10.10 on page 69 for a summary of software changes included in this release.

Configuration and calibration of the indicator can be accomplished using the indicator front panel keys, the EDP command set, or the Revolution Scaleware™ configuration utility. See Section 3.1 on page 13 for information about configuration methods.

1.0 Introduction

The IQ plus 710 is a single-channel digital weight indicator housed in a NEMA 4X/IP66-rated stainless steel enclosure. The indicator front panel consists of a 29-button keypad with a large, seven-digit, 14-segment, vacuum fluorescent display, two-character dot-matrix annunciator field, and a sixteen-character dot-matrix prompt field. Features include:

- Drives up to eight 350Ω or sixteen 700Ω load cells
- Supports 4- and 6-wire load cell connections
- Eight configurable digital inputs
- Eight digital outputs
- Electronic data processing (EDP) port for full duplex RS-232 or RS-485 communications at up to 19200 bps
- Printer port for output-only RS-232 and 20 mA current loop communications at up to 19200 bps
- Optional analog output module provides 0–10 VDC or 4–20 mA tracking of gross or net weight values
- Optional Remote I/O Interface for communication with PLC® and SLC™ controllers using the Allen-Bradley® Remote I/O® networks¹
- Available in 115 VAC and 230 VAC versions

The IQ plus 710 is NTEP-certified for Classes III and III L at 10,000 divisions. See Section 10.11 on page 70 for detailed specifications.



Warning

Some procedures described in this manual require work inside the indicator enclosure. These procedures are to be performed by qualified service personnel only.



Authorized distributors and their employees can view or download this manual from the Rice Lake Weighing Systems distributor site at www.rlws.com.

The *Operator Card* included with this manual provides basic operating instructions for users of the IQ plus 710. Please leave the *Operator Card* with the indicator when installation and configuration are complete.

1.1 Operating Modes

The IQ plus 710 has three modes of operation:

Normal (weighing) mode

Normal mode is the “production” mode of the indicator. The indicator displays gross, net, or tare weights as required, using the secondary display to indicate scale status and the type of weight value displayed. Once configuration is complete and a legal seal is affixed to the back of the indicator, this is the only mode in which the IQ plus 710 can operate.

Setup mode

Most of the procedures described in this manual require the indicator to be in setup mode, including configuration and calibration.

To enter setup mode, remove the large fillister head screw from the enclosure backplate. Insert a screwdriver or a similar tool into the access hole and press the setup switch once. The indicator display changes to show the word *CONFIG*.

Test mode

Test mode provides a number of diagnostic functions for the IQ plus 710 indicator. Like setup mode, test mode is entered using the setup switch. See Section 10.8 on page 67 for more information about entering and using test mode.

1. Allen-Bradley®, PLC®, and SLC™ are trademarks of Allen-Bradley Company, Inc., a Rockwell International company.

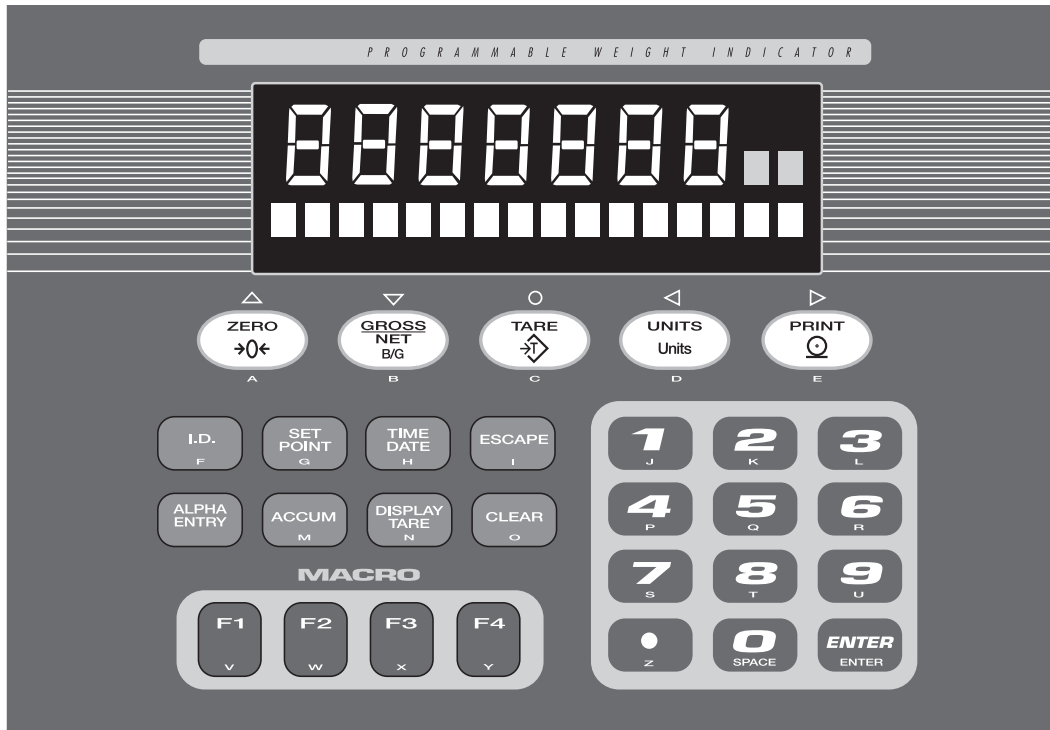

Figure 1-1. IQ plus 710 Front Panel

1.2 Front Panel Display

Figure 1-1 shows the IQ plus 710 front panel keys and the key functions assigned in normal mode.

The IQ plus 710 display is divided into three areas (see Figure 1-2):

- The primary display consists of seven large, 14-segment digits used to display weight data.
- A two-digit annunciator shows the units associated with the displayed value: lb=pounds, kg=kilograms, oz=ounces, T=short tons, t=metric tons, LT=long tons, g=grams, GN=grains. When the units configured are troy pounds or troy ounces, the word *troy* is shown in the secondary display area in addition to the lb or oz annunciator. The units can also be set to NONE (no units information displayed).

The two-digit annunciator also displays whether the indicator is in numeric entry (NE) or alpha entry (AE) mode for some operations.

The 16-digit secondary display is used to display the weighing mode (Gross/Brutto or Net) and status indicators, including standstill (▲▲) and center of zero (▶◀).

The symbols shown over the keys in Figure 1-1 (representing up, down, enter, left, right) describe the key functions assigned in setup mode. In setup mode, the keys are used to navigate through menus, select digits within numeric values, and increment/decrement values. See Section 3.1.3 on page 14 for information about using the front panel keys in setup mode.

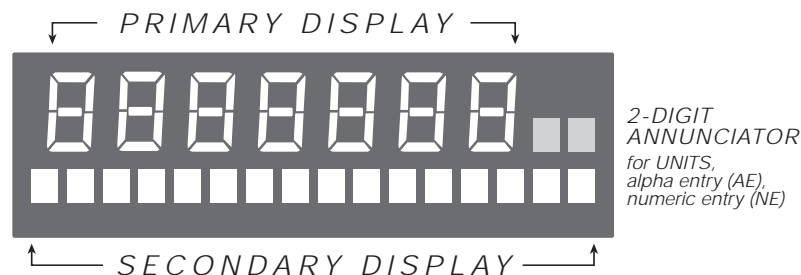

Figure 1-2. IQ plus 710 Front Panel Display Areas

1.3 Indicator Operations

Basic IQ plus 710 operations are summarized below:

1.3.1 Toggle Gross/Net Mode



Press the **GROSS/NET** key to switch the display mode from gross to net, or from net to gross. If a tare value has been entered or acquired, the net value is the gross weight minus the tare. If no tare has been entered or acquired, the display remains in gross mode.

Gross mode is indicated by the word **Gross** (or **Bruttø**) on the secondary display; net mode is indicated by the word **Net**.

1.3.2 Toggle Units

Press the **UNITS** key to switch between primary and secondary units. The units identifier is shown to the right of the primary display. Troy ounces and troy pounds are indicated by the word **troy** on the secondary display.

1.3.3 Zero Scale

1. In gross mode, remove all weight from the scale and wait for the standstill annunciator ().
2. Press the **ZERO** key. The center of zero () annunciator lights to indicate the scale is zeroed.

1.3.4 Acquire Tare

1. Place container on scale and wait for the standstill annunciator ().
2. Press the **TARE** key to acquire the tare weight of the container.
3. Display shifts to net weight and shows the word **Net** on the secondary display.

To display the current tare value, press the **DISPLAY TARE** key.

1.3.5 Remove Stored Tare Value

1. Remove all weight from the scale and wait for the standstill annunciator ().
2. Press the **ZERO** key. Display shifts to gross weight and shows the word **Gross** on the secondary display.

1.3.6 Print Ticket

1. Wait for the standstill annunciator ().
2. Press the **PRINT** key to send data to the serial port.

1.3.7 Display or Change Time and Date

To display the date, press the **TIME/DATE** key once; press **TIME/DATE** a second time to display the time.

To set the date, press the **TIME/DATE** key once. Use the numeric keypad to enter the date, then press the **ENTER** key. The date must be entered in the date format configured for the indicator: *MMDDYY* or *DDMMYY*.

To set the time, press the **TIME/DATE** key twice. Use the numeric keypad to enter the time in 24-hour format, then press the **ENTER** key.

1.3.8 Display or Change Setpoint Value

To display a setpoint value, press the **SETPOINT** key a number of times equal to the setpoint number. For example, to display the value of setpoint 4, press the **SETPOINT** key four times.

To change the setpoint value, display the current value, then use the numeric keypad to enter the new value and press the **ENTER** key.

NOTE: Some indicator configurations may not allow setpoint values to be changed through the front panel or may require a password to display or change the setpoint value.

1.3.9 Turn Setpoint On or Off

To turn a setpoint off at the front panel, press the **SETPOINT** key a number of times equal to the setpoint number. With the correct setpoint displayed, press **CLEAR** to turn the setpoint off.

To re-enable a setpoint on that has been turned off at the front panel, press the **SETPOINT** key until the correct setpoint is displayed, then press **ENTER** to turn the setpoint back on.

NOTE: Some indicator configurations may not allow setpoints to be turned off through the front panel or may require a password to turn the setpoint on and off.

1.3.10 Display or Clear Accumulator

If the accumulator function is enabled, the current net weight is added to the accumulator each time the indicator performs a print operation.

- To display the current accumulator value, press the **ACCUM** key.
- To clear the accumulator, press **ACCUM** to show the current value, then press the **CLEAR** key twice to reset the accumulator.

2.0 Installation

This section describes procedures for connecting load cells, digital I/O, and serial communications cables to the IQ plus 710 indicator. Instructions for field installation of the analog output option and replacement of the CPU board are included, along with assembly drawings and parts lists for the service technician.

Caution

- Use a wrist strap to ground yourself and protect components from electrostatic discharge (ESD) when working inside the indicator enclosure.
- This unit uses double pole/neutral fusing which could create an electric shock hazard. Procedures requiring work inside the indicator must be performed by qualified service personnel only.

2.1 Unpacking and Assembly

Immediately after unpacking, visually inspect the IQ plus 710 to ensure all components are included and undamaged. The shipping carton should contain the indicator with attached tilt stand, this manual, and a parts kit. If any parts were damaged in shipment, notify Rice Lake Weighing Systems and the shipper immediately.

The parts kit contains the items listed below:

- Capacity and identification labels.
- Two 8-32NC x 7/16 fillister head screws (PN 30623). These screws occupy the holes above and on either side of the setup screw on the indicator backplate (see Figure 2-2 on page 7).
- Ten 8-32NC x 3/8 machine screws (PN 14862) for the indicator backplate (see #29 in Figure 2-6 on page 12).
- Twelve bonded sealing washers (PN 45042) for backplate screws included in the parts kit.
- Four cord grip reducing glands (PN 15664).
- Four rubber bumpers (“feet”) for the tilt stand, PN 42149.
- 6 cable ties, PN 15631.

2.2 Enclosure Disassembly

The indicator enclosure must be opened to connect cables for load cells, communications, digital inputs, digital outputs, and analog output.

 **Warning** *The IQ plus 710 has no on/off switch. Before opening the unit, ensure the power cord is disconnected from the power outlet.*

Ensure power to the indicator is disconnected, then place the indicator face-down on an antistatic work mat. Remove the screws that hold the backplate to the enclosure body, then lift the backplate away from the enclosure and set it aside.

2.3 Cable Connections

The IQ plus 710 provides five cord grips for cabling into the indicator: one for the power cord, four to accommodate load cell, communications, digital I/O, and analog output cables. Three of the four free cord grips come with a plug installed to prevent moisture from entering the enclosure. Depending on your application, remove the plug from any cord grip that will be used and install cables as required.

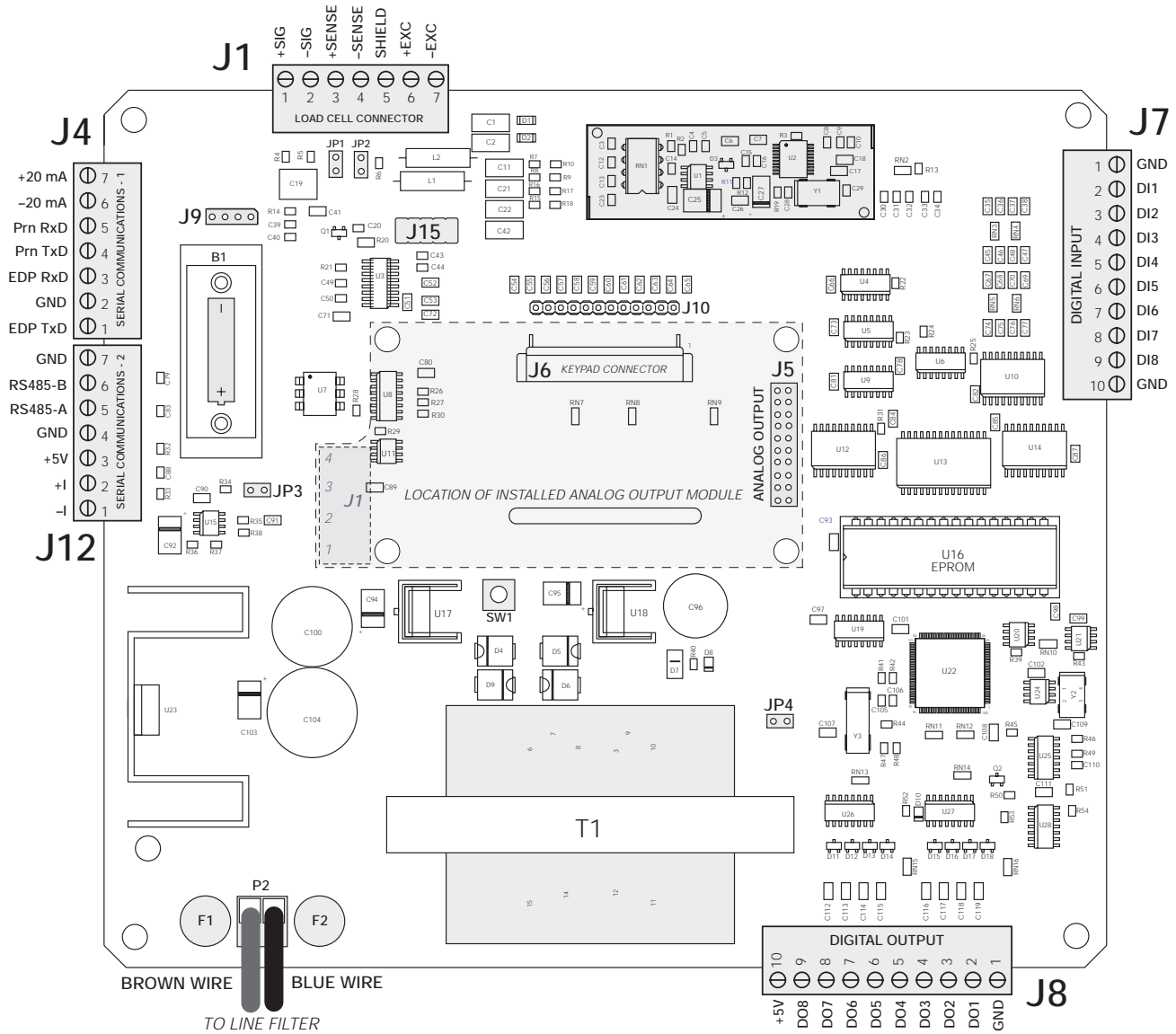

Figure 2-1. IQ plus 710 CPU and Power Supply Board, Rev. 2

2.3.1 Load Cells

To attach cable from a load cell or junction box, remove connector J1 from the board. The connector plugs into a header on the board (see Figure 2-1).

Wire the load cell cable from the load cell or junction box to connector J1 as shown in Table 2-1. If using 6-wire load cell cable (with sense wires), remove jumpers JP1 and JP2 before reinstalling connector J1 (see Figure 2-1). For 4-wire installation, leave jumpers JP1 and JP2 on.

When connections are complete, reinstall connector J1 on the board and use two cable ties to secure the load cell cable to the inside of the enclosure.

J1 Pin	Function
1	+SIG
2	-SIG
3	+SENSE
4	-SENSE
5	SHIELD
6	+EXC
7	-EXC

For 6-wire load cell connections, remove jumpers JP1 and JP2.

Table 2-1. J1 Pin Assignments

2.3.2 Serial Communications

To attach serial communications cables, remove connector J4 or J12 from the board. Connector J4 provides connections for the EDP (Electronic Data Processing) port, printer port, and 20 mA current loop transmit signals; connector J12 provides RS-485 and 20 mA current loop receive signals. Table 2-2 shows the pin assignments for connectors J12 and J4.

Once cables are attached, reconnect J12 or J4 to the header on the board. Use cable ties to secure serial cables to the inside of the enclosure.

The EDP port supports RS-232 or RS-485 communications; the printer port provides active 20 mA output and RS-232 transmission. Both ports are configured using the SERIAL menu. See Section 3.0 on page 13 for configuration information.

Connector	Pin	Signal
J4	1	EDP TxD
	2	GND
	3	EDP RxD
	4	Printer TxD
	5	Printer RxD
	6	-20 mA TxD
	7	+20 mA TxD
J12	1	-I (-20 mA RxD)
	2	+I (+20 mA RxD)
	3	+5V
	4	GND
	5	RS485-A
	6	RS485-B
	7	GND

Table 2-2. J4 and J12 Pin Assignments

2.3.3 Digital I/O

Digital inputs can be set to provide several indicator functions, including all keypad functions. The inputs are active (on) with low voltage (0 VDC) and can be driven by TTL or 5V logic without additional hardware. Use the DIG IN menu to configure the digital inputs.

Digital outputs are typically used to drive relays that control other equipment. Up to eight relays can be mounted inside the flat front enclosure; up to four relays can be mounted inside the sloped front enclosure. Use the SETPNTS menu to configure digital outputs.

Table 2-3 shows the pin assignments for connectors J7 and J8.

Pin	J7 Signal	J8 SIGNAL
1	GND	GND
2	DI1	DO1
3	DI2	DO2
4	DI3	DO3
5	DI4	DO4
6	DI5	DO5
7	DI6	DO6
8	DI7	DO7
9	DI8	DO8
10	GND	+5V

Table 2-3. J7 and J8 Pin Assignments (Digital I/O)

2.3.4 Analog Output

If the optional analog output module is installed, attach the output cable to connector J1 on the analog output board. Table 2-4 lists the analog output pin assignments.

Use the ALGOUT menu to configure and calibrate the analog output module when cabling is complete. See Section 2.4 for information about installing the analog output module.

Pin	Signal
1	+ Current Out
2	- Current Out
3	+ Voltage Out
4	- Voltage Out

Table 2-4. Analog Output Module Pin Assignments

2.4 Analog Output Module Installation

To install or replace the analog output module, follow the steps listed in Section 2.2 on page 4 for opening the IQ plus 710 enclosure.

Mount the analog output module on its standoffs in the location shown in Figure 2-1 on page 5 and plug the module input into connector J5 on the IQ plus 710 board. Connect the output cable to the analog output module as shown in Table 2-4, then reassemble the enclosure (Section 2.5).

See Section 10.7 on page 67 for analog output calibration procedures.

2.5 Enclosure Reassembly

Once cabling is complete, position the backplate over the enclosure and reinstall the backplate screws. Use the torque pattern shown in Figure 2-2 to prevent distorting the backplate gasket. Torque screws to 10 in-lb (1.13 N-m).

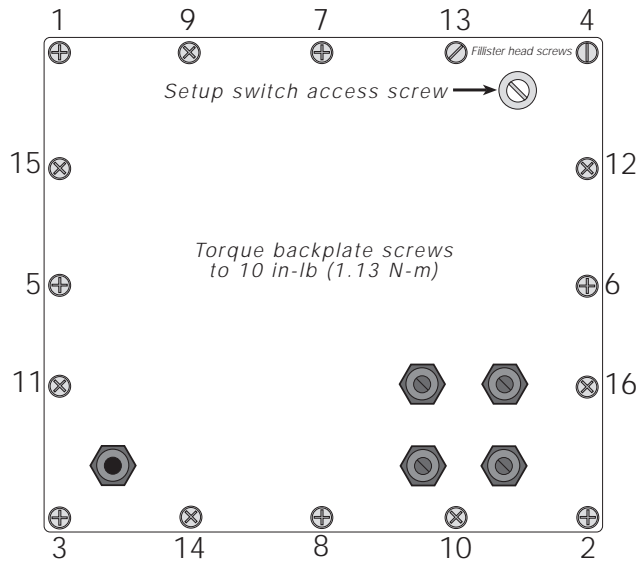

Figure 2-2. IQ plus 710 Enclosure Backplate

2.6 Board Removal

If you must remove the IQ plus 710 CPU board, use the following procedure:

1. Disconnect power to the indicator. Loosen cord grips and remove backplate as described in Section 2.2 on page 4.
2. Unplug connectors J1 (load cell cable), J4 and J12 (serial communications), J7 and J8 (digital I/O), J6 (keypad ribbon cable), and JP4 (setup switch). If an analog output board is installed, disconnect the analog output cable. See Figure 2-1 on page 5 for connector locations.
3. Remove the standoff and three nuts from the corners of the CPU board.
4. Cut the cable tie that holds the line filter load wires to the enclosure.
5. Lift the board off of its spacers just far enough to access the setscrews that secure the line filter load wires at connector P2. Use a small screwdriver to loosen the setscrews and disconnect power to the board.
6. Remove the CPU board from the enclosure.

To replace the CPU board, reverse the above procedure. Be sure to reinstall cable ties to secure all cables inside the indicator enclosure.

2.7 Replacement Parts

Table 2-5 lists replacement parts for the IQ plus 710, including all parts referenced in Figures 2-3 through 2-7.

Ref Number	PN	Description (Quantity)	Figure
1	41397	Enclosure, sloped front (1)	Figure 2-6 on page 12
	41401	Enclosure, flat front (1)	
2	41398	Enclosure backplate (1)	Figure 2-3 on page 9
3	14626	Kep nuts, 8-32NC hex (13)	Figure 2-6 on page 12
4	30375	Nylon seal rings for cable grips (4)	Figure 2-3 on page 9
5	14621	Kep nuts, 6-32NC hex (4–flat enclosure; 6–sloped)	Figure 2-5 on page 11
6	15626	Cable grips, PG9 (4)	Figure 2-3 on page 9
7	15627	Locknuts, PCN9 (4)	
8	15650*	Cable tie mounts (8)	
10	19538	Cable grip plugs (3)	Figure 2-3 on page 9
11	44676	Sealing washer for setup switch access screw (1)	
12	42640	Setup switch access screw, 1/4 x 28NF x 1/4 (1)	
13	41965	Power cord assembly, 115VAC (1)	
	45254	Power cord assembly, 230VAC (1)	
15	16892	Ground/Earth label (1)	Figure 2-4 on page 10

Table 2-5. Replacement Parts

Ref Number	PN	Description (Quantity)	Figure
16	45402	Bezel, sloped front (1)	Figure 2-6 on page 12
	41399	Bezel, flat front (1)	
17	41385	Switch panel membrane (1)	Figure 2-6 on page 12
18	41400	Backplate gasket (1)	Figure 2-3 on page 9
19	45043	Ground wire, 4 in w/ No. 8 eye connector (1)	Figure 2-4 on page 10
21	46027	Setup switch mounting bracket (1)	Figure 2-5 on page 11
24	44844	Setup switch assembly (1)	
25	30342	Wing knobs for tilt stand (2)	Figure 2-7 on page 12
26	29635	Tilt stand (1)	
27	15144	Nylon washers for tilt stand, 1/4 x 1 x 1/16 (2)	
28	45891	Line filter assembly (1)	Figure 2-4 on page 10
29	14862*	Screws, 8-32NC x 3/8 (4)	Figure 2-7 on page 12
30	16903	Model/serial number label (1)	—
31	46252	Bezel gasket, sloped front (1)	Figure 2-6 on page 12
	45076	Bezel gasket, flat front (1)	
36	45401	CPU board mounting tab, sloped front models (1)	Figure 2-5 on page 11
37	15134	Lock washers, No. 8 (4)	Figure 2-4 on page 10
38	48027	Nylon spacers for board mounting (4)	Figure 2-5 on page 11
39	45042*	Sealing washers (4)	Figure 2-7 on page 12
40	15369	Standoffs, fem 6-32NC x 3/4 (3)	Figure 2-4 on page 10
41	44541	Display and CPU board assembly, Rev 2, 115 VAC (1)	Figure 2-5 on page 11
	44540	Display and CPU board assembly, Rev 2, 230 VAC (1)	
42	19644	3V cylindrical lithium battery	
—	42104	7-position connectors for J1, J4, and J12 (3)	Figure 2-1 on page 5
—	46420	10-position connectors for J7 and J8 (2)	
—	45484	160 mA TR5 subminiature fuses (2), 115 VAC	F1 and F2 in Figure 2-1 on page 5
	45107	80 mA TR5 subminiature fuses (2), 230 VAC	
<i>The following parts apply only to units using the Rev 1 CPU board with cable interface board</i>			
9	14839	Machine screw, 6-32NC x 1/4 (4)	Not shown
20	45312	Interface board assembly (1)	
24	45414	Serial cable, interface board to CPU board (1)	
32	45388	Interface board mounting bracket, top (1)	
33	45387	Interface board mounting bracket, side (1)	
—	46444	315 mA TR5 subminiature fuses (2), 115 VAC	
	46445	160 mA TR5 subminiature fuses (2), 230 VAC	
* Additional parts included in parts kit.			
 Caution To protect against the risk of fire, replace fuses only with same type and rating fuse. See Section 10.11 on page 70 for complete fuse specifications.			

Table 2-5. Replacement Parts (Continued)

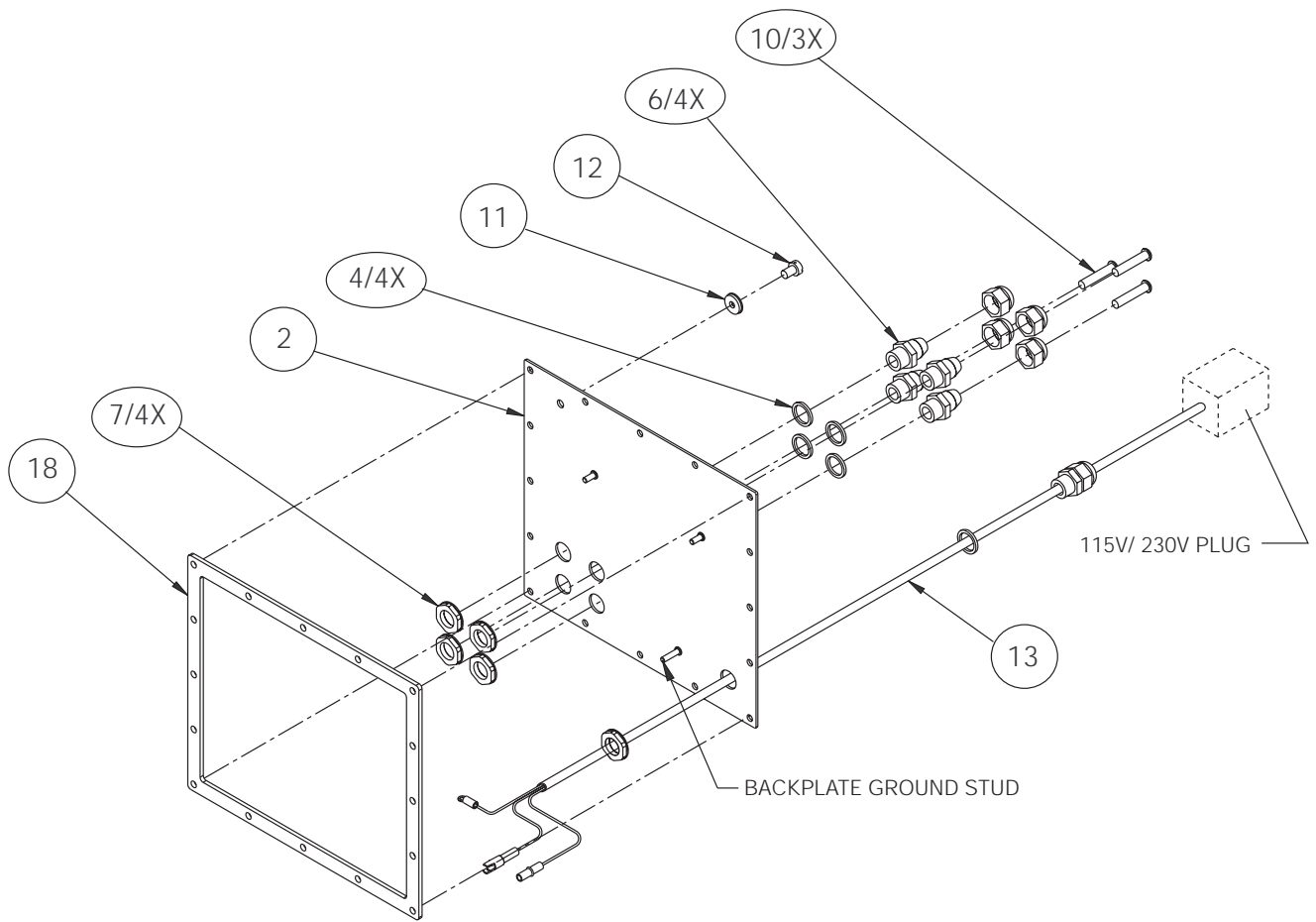

Figure 2-3. Backplate Assembly

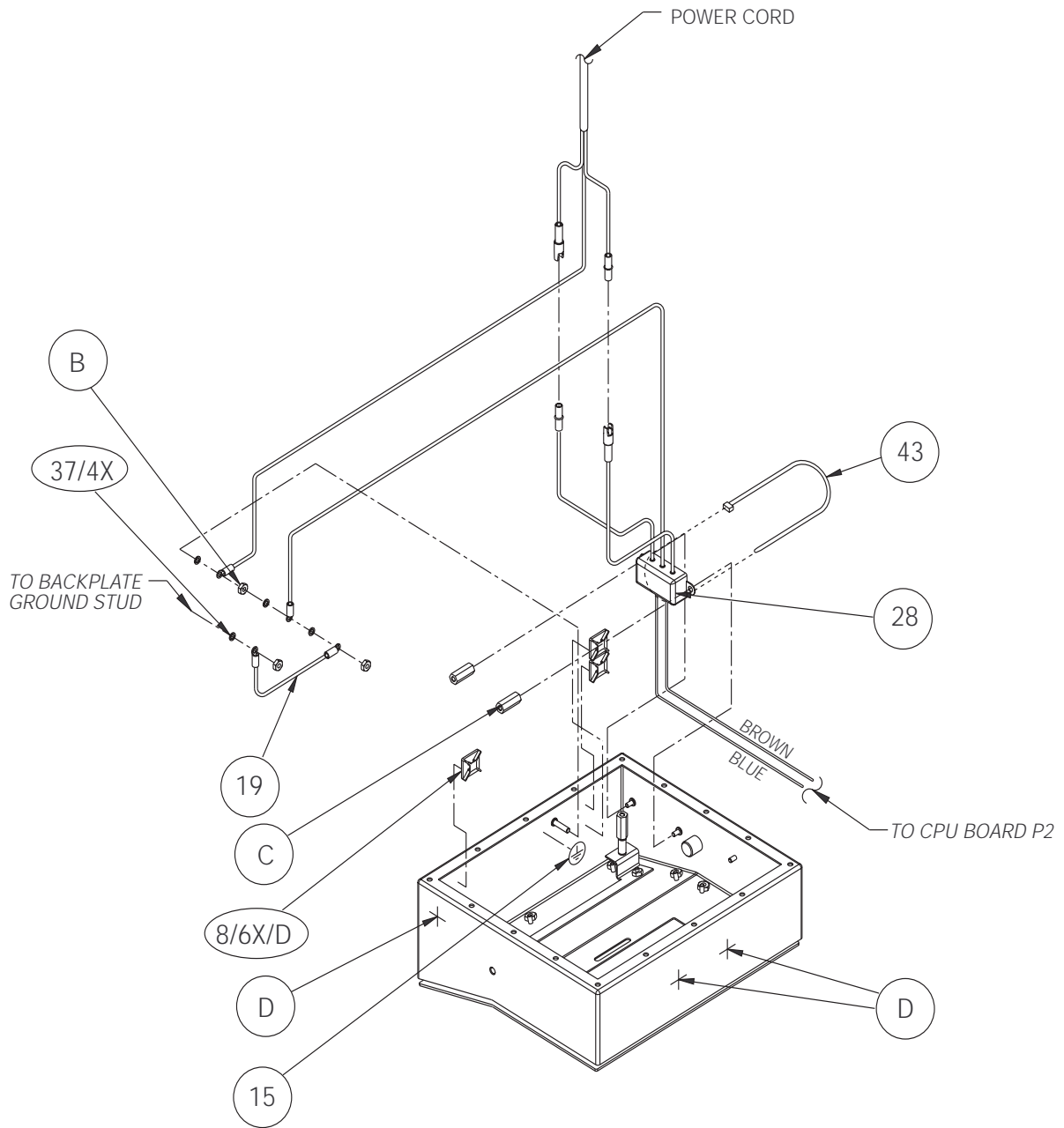

Figure 2-4. Enclosure and Line Filter Assembly

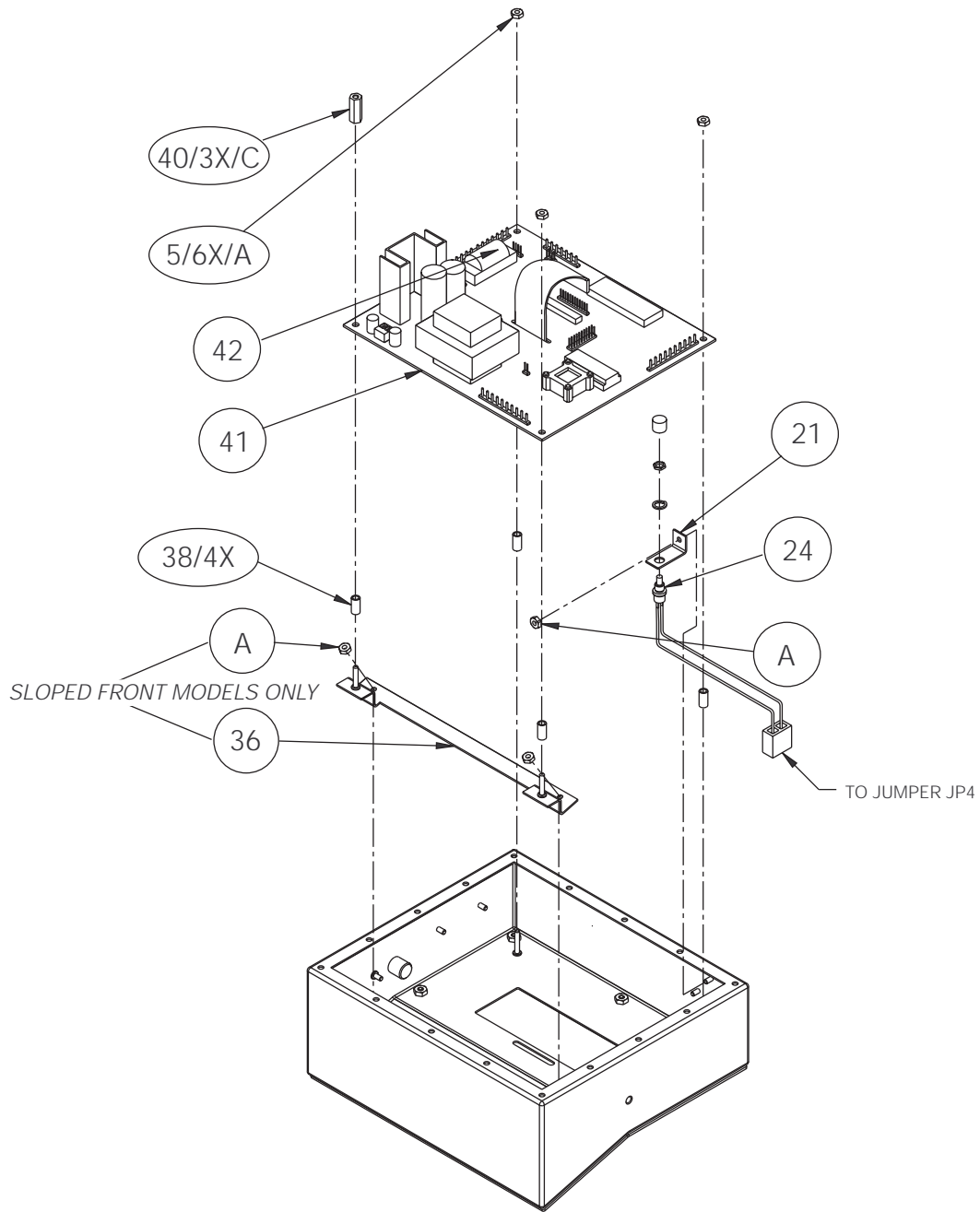

Figure 2-5. Enclosure and CPU Board Assembly

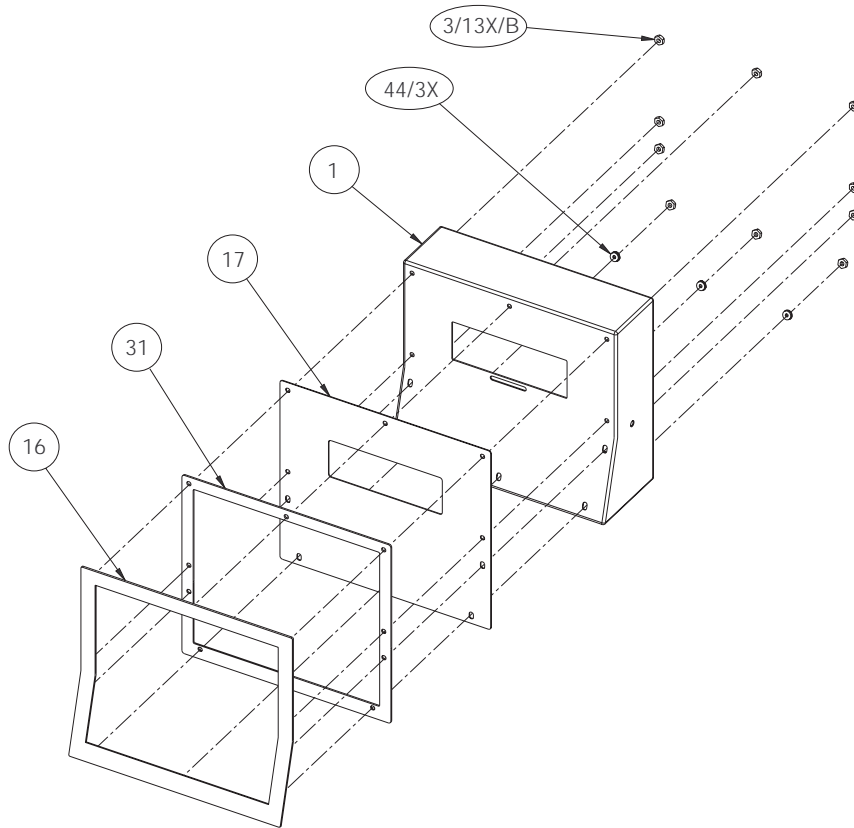

Figure 2-6. Bezel Assembly

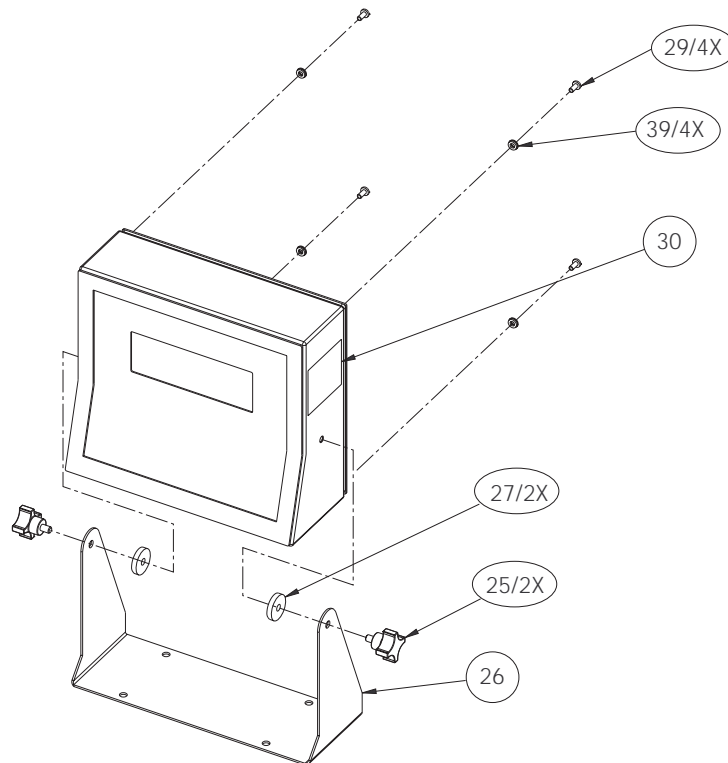

Figure 2-7. Tilt Stand Assembly

3.0 Configuration

To configure the IQ plus 710 indicator, the indicator must be placed in setup mode. The setup switch is accessed by removing the large fillister head screw on the enclosure backplate. Switch position is changed by inserting a screwdriver into the access hole and pressing the switch.

When the indicator is placed in setup mode, the word *CONFIG* is shown on the display. The CONFIG menu is the first of ten main menus used to configure the indicator. Detailed descriptions of these menus are given in Section 3.2. When configuration is complete, return to the CONFIG menu and press the Δ (ZERO) key to exit setup mode, then replace the setup switch access screw.

3.1 Configuration Methods

The IQ plus 710 indicator can be configured by using the front panel keys to navigate through a series of configuration menus or by sending commands or configuration data to the EDP port. Configuration using the menus is described in Section 3.1.3.

Configuration using the EDP port can be accomplished using either the EDP command set described in Section 5.0 or the Revolution™ Scaleware configuration utility.

3.1.1 Revolution Scaleware Configuration

The Revolution Scaleware configuration utility provides the preferred method for configuring the IQ plus 710 indicator. Revolution runs on a personal computer to set configuration parameters for the indicator. When Revolution configuration is complete, configuration data is downloaded to the indicator.



Figure 3-1. Sample Revolution Scaleware Configuration Display

Revolution supports both uploading and downloading of indicator configuration data. This capability allows configuration data to be retrieved from one indicator, edited, then downloaded to another.

To use Revolution Scaleware, do the following:

1. Install Revolution on an IBM-compatible personal computer running Windows® 3.11 or Windows 95. Minimum system requirements are 4MB of extended memory and at least 5MB of available hard disk space.
2. With both indicator and PC powered off, connect the PC serial port to the RS-232 pins on the indicator EDP port.
3. Power up the PC and the indicator. Use the setup switch to place the indicator in setup mode.
4. Start the Revolution Scaleware program.

Figure 3-1 shows an example of one of the Revolution Scaleware configuration displays.

Revolution provides online help for each of its configuration displays. Parameter descriptions provided in this manual for front panel configuration can also be used when configuring the indicator using Revolution: the interface is different, but the parameters set are the same.

3.1.2 EDP Command Configuration

The EDP command set can be used to configure the IQ plus 710 indicator using either a personal computer, terminal, or remote keyboard. Like Revolution, EDP command configuration sends commands to the indicator EDP port; unlike Revolution, EDP commands can be sent using any external device capable of sending ASCII characters over a serial connection.

EDP commands duplicate the functions available using the indicator front panel and provide some functions not otherwise available. EDP commands can be used to simulate pressing front panel keys, to configure the indicator, or to dump lists of parameter settings. See Section 5.0 on page 36 for more information about using the EDP command set.

3.1.3 Front Panel Configuration

The IQ plus 710 indicator can be configured using a series of menus accessed through the indicator front panel when the indicator is in setup mode. Table 3-1 summarizes the functions of each of the main menus.

Menu		Menu Function
CONFIG	Configuration	Configure grads, zero tracking, zero range, motion band, overload, tare function, power-up mode, and digital filtering parameters.
FORMAT	Format	Set format of primary and secondary units, decimal format, and display rate.
CALIBR	Calibration	Calibrate indicator. See Section 4.0 on page 33 for calibration procedures.
SERIAL	Serial	Configure EDP and printer serial ports.
PROGRM	Program	Set date and time formats, truck mode, passwords, keyboard locks, regulatory mode, and initial consecutive number value; enable accumulator; define macro prompts and program macros.
PFORMT	Print Format	Set print format used for header, gross, net, truck in/out, setpoint, and EDP format tickets. See Section 6.0 for more information.
SETPNTS	Setpoints	Configure setpoints, batching mode, and assign setpoint names.
DIG IN	Digital Input	Assign digital input functions.
ALGOUT	Analog Output	Configure analog output module. Used only if analog output option is installed.
VERSION	Version	Display installed software version number.

Table 3-1. IQ plus 710 Menu Summary

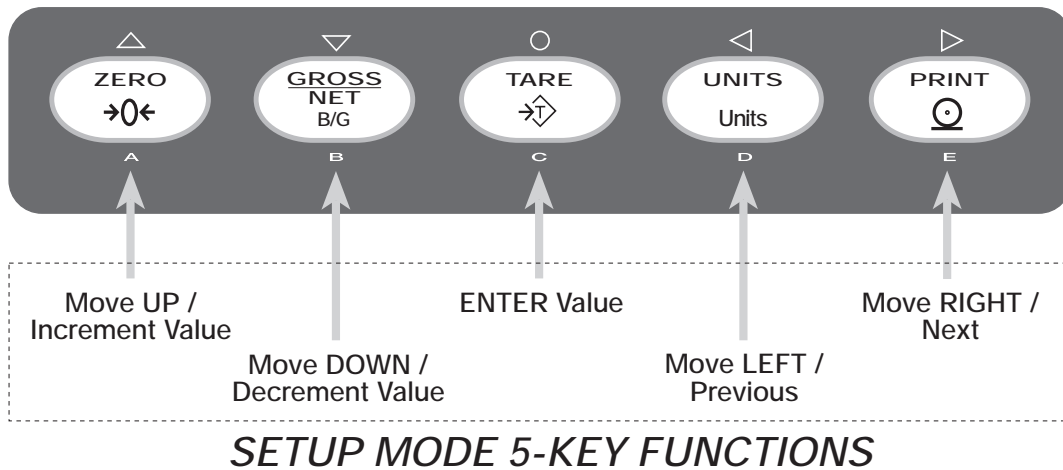

Figure 3-2. Five-Key Keypad Functions in Setup Mode

Four front panel keys are used as directional keys to navigate through the menus in setup mode (see Figure 3-2). The UNITS (◀) and PRINT (▶) keys scroll left and right (horizontally) on the same menu level; ZERO (△) and GROSS/NET (▽) move up and down (vertically) to different menu levels. The TARE key (○) serves as an Enter key for selecting parameter values within the menu. A label over each of these keys identifies the direction provided by the key when navigating through the setup menus.

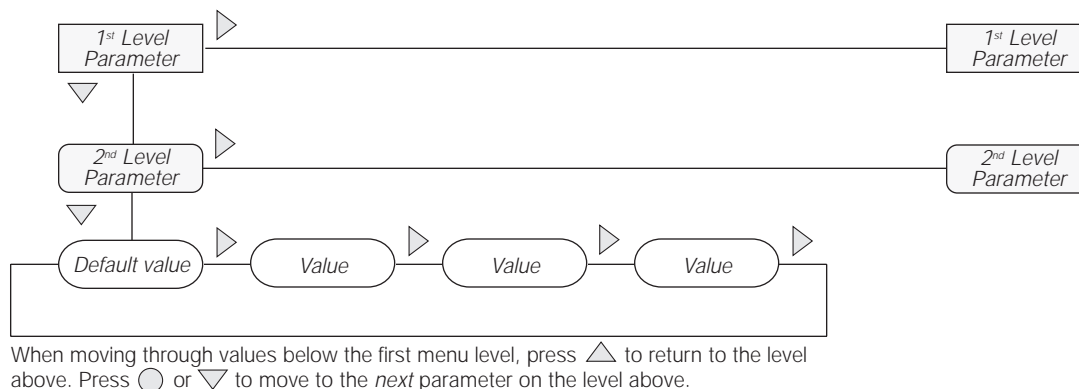

Figure 3-3. Setup Mode Menu Navigation

To select a parameter, press ◀ or ▶ to scroll left or right until the desired menu group appears on the display, then press ▽ to move down to the submenu or parameter you want. When moving through the menu parameters, the default or previously selected value appears first on the display.

To change a parameter value, scroll left or right to view the values for that parameter. When the desired value appears on the display, press ○ to select the value and move back up one level. To edit numerical values, use the numeric keypad on the indicator front panel.

3.2 Menu Structures and Parameter Descriptions

The following sections provide graphic representations of the IQ plus 710 menu structures. In the actual menu structure, the settings you choose under each parameter are arranged horizontally. To save page space, menu choices are shown in vertical columns. The factory default setting appears at the top of each column. Parameters shown surrounded by a dotted-line box only appear under the special circumstances explained under each box.

Most menu diagrams are accompanied by one or more tables that describe all parameters and parameter values associated with that menu option. Default parameter values are shown in bold type.

3.2.1 Configuration Menu

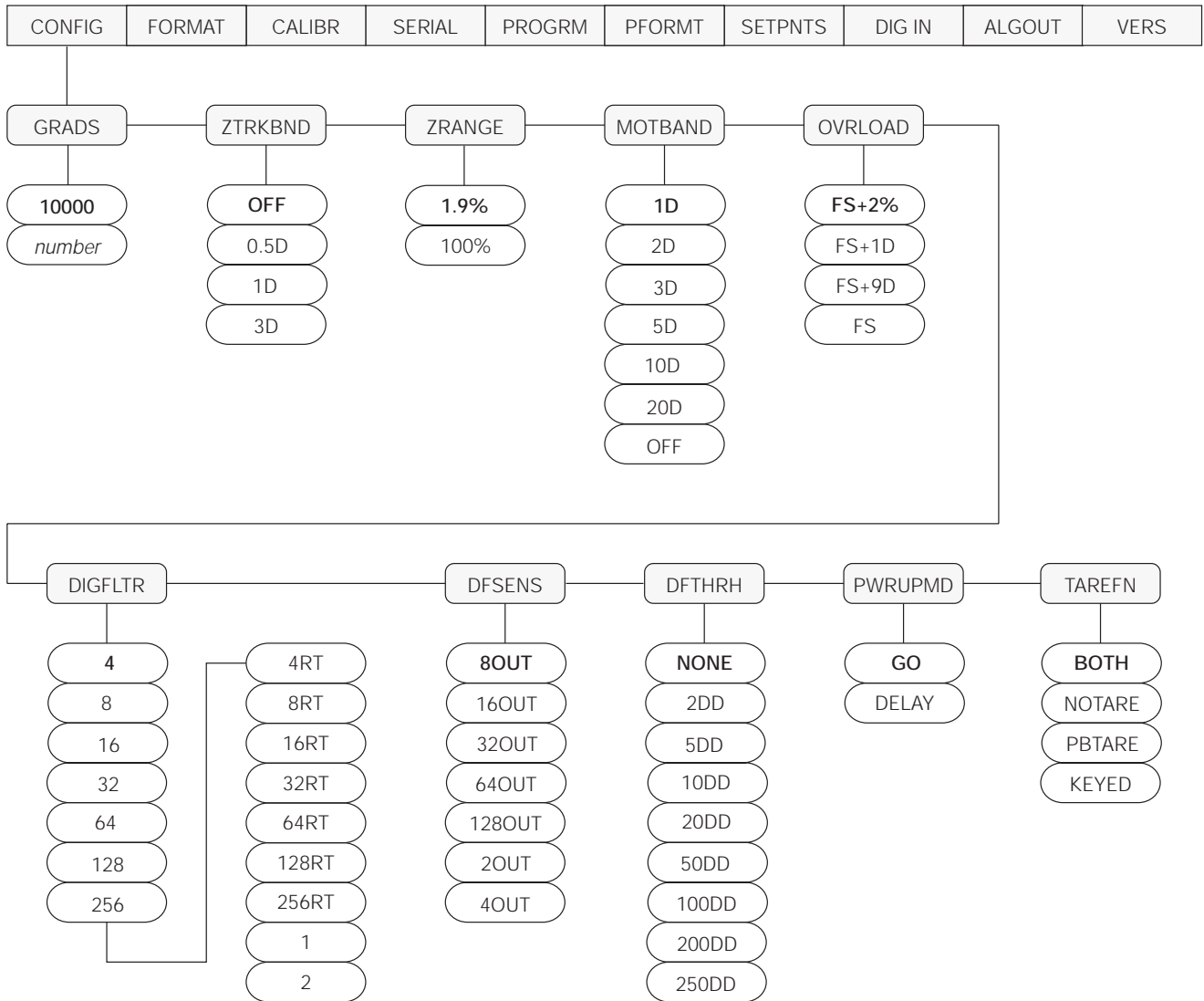

Figure 3-4. Configuration Menu

CONFIG Menu		
Parameter	Choices	Description
<i>Level 2 submenus</i>		
GRADS	10000 <i>number</i>	Specifies the number of full scale graduations. The value entered must be in the range 1–100000 and should be consistent with legal requirements and environmental limits on system resolution. To calculate GRADS, use the formula, $GRADS = Capacity / Display Divisions$. Display divisions for primary and secondary units are specified on the FORMAT menu.
ZTRKBND	OFF 0.5D 1D 3D	Automatically zeroes the scale when within the range specified, as long as the input is within the ZRANGE and scale is at standstill. Selections are \pm display divisions. Maximum legal value varies depending on local regulations.
ZRANGE	1.9% 100%	Selects the range within which the scale can be zeroed. The 1.9% selection is \pm 1.9% around the calibrated zero point, for a total range of 3.8%. Indicator must be at standstill to zero the scale. Use 1.9% for legal-for-trade applications.
MOTBAND	1D 2D 3D 5D 10D 20D OFF	Sets the level, in display divisions, at which scale motion is detected. If motion is not detected for 1 second or more, the standstill symbol lights. Some operations, including print, tare, and zero, require the scale to be at standstill. Maximum legal value varies depending on local regulations. If this parameter is set to OFF, the standstill annunciator will not light; operations normally requiring standstill (zero, tare, print) are performed regardless of scale motion. If OFF is selected, ZTRKBND must also be set to OFF.
OVRLD	FS+2% FS+1D FS+9D FS	Determines the point at which the display blanks and an out-of-range error message is displayed. Maximum legal value varies depending on local regulations.
DIGFLTR	4 8 16 32 64 128 256 4RT 8RT 16RT 32RT 64RT 128RT 256RT 1 2	Selects the digital filtering rate used to reduce the effects of mechanical vibration from the immediate area of the scale. Choices indicate the number of A/D conversions per update that are averaged to obtain the displayed reading. A higher number gives a more accurate display by minimizing the effect of a few noisy readings, but slows down the settling rate of the indicator.
DFSNS	8OUT 16OUT 32OUT 64OUT 128OUT 2OUT 4OUT	Digital filter cutout sensitivity. Specifies the number of consecutive readings that must fall outside the filter threshold (DFTHR parameter) before digital filtering is suspended.

Table 3-2. Configuration Menu Parameters

CONFIG Menu		
Parameter	Choices	Description
DFTHRH	NONE 2DD 5DD 10DD 20DD 50DD 100DD 200DD 250DD	Digital filter cutout threshold. Specifies the filter threshold, in display divisions. When a specified number of consecutive scale readings (DFSENS parameter) fall outside of this threshold, digital filtering is suspended.
PWRUPMD	GO DELAY	Power up mode. In GO mode, the indicator goes into operation immediately after a brief power up display test. In DELAY mode, the indicator performs a power up display test, then enters a 30-second warm up period. If no motion is detected during the warm up period, the indicator becomes operational when the warm up period ends; if motion is detected, the delay timer is reset and the warm up period repeated.
TAREFN	BOTH NOTARE PBTARE KEYED	Enables or disables push-button and keyed tares. Possible values are: BOTH: Both push-button and keyed tares are enabled NOTARE: No tare allowed (gross mode only) PBTARE: Push-button tares enabled KEYED: Keyed tare enabled

Table 3-2. Configuration Menu Parameters (Continued)

3.2.2 Format Menu

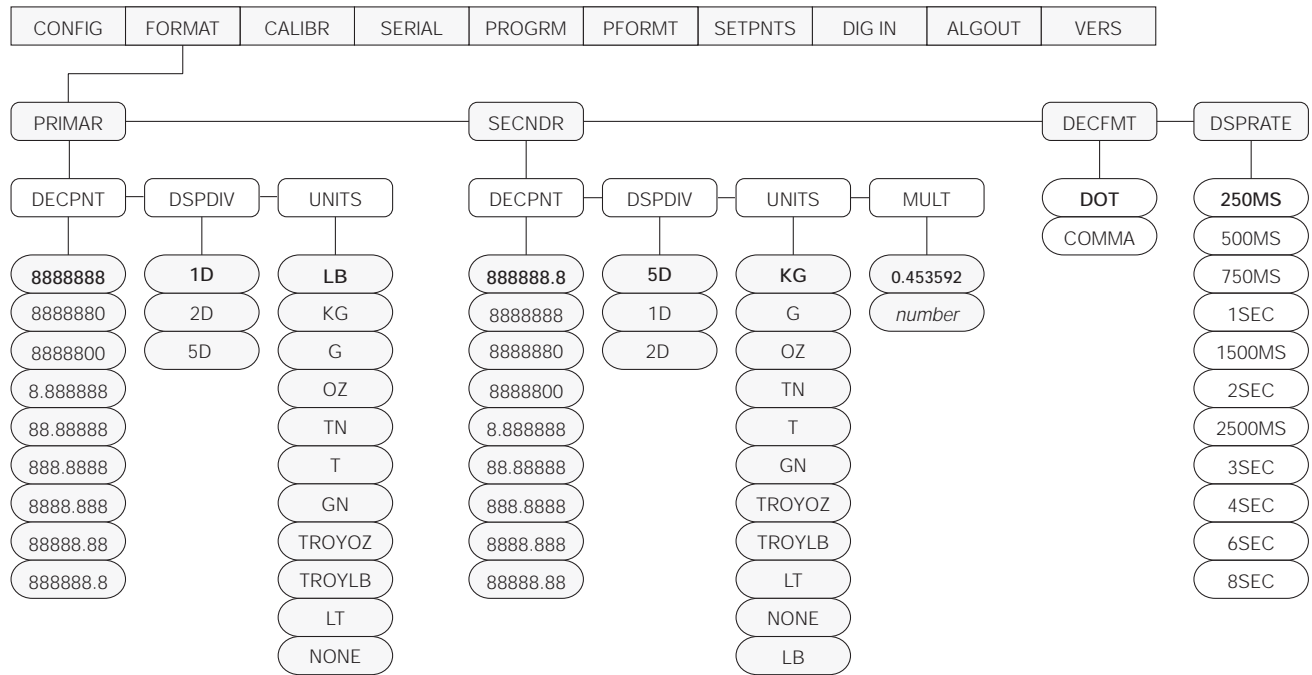

Figure 3-5. Format Menu

FORMAT Menu		
Parameter	Choices	Description
<i>Level 2 submenus</i>		
PRIMAR	DECPNT DSPDIV UNITS	Specifies the decimal position, display divisions, and units used for the primary units. See Level 3 submenu parameter descriptions.
SECNDR	DECPNT DSPDIV UNITS MULT	Specifies the decimal position, display divisions, units, and conversion multiplier used for the secondary units. See Level 3 submenu parameter descriptions.
DECfmt	DOT COMMA	Specifies whether decimal numbers are displayed using a period (DOT) or comma as the decimal symbol.
DSPrATE	250MS 500MS 750MS 1SEC 1500MS 2SEC 2500MS 3SEC 4SEC 6SEC 8SEC	Display rate. Sets the update rate for displayed values. Values are in milliseconds (MS) or seconds (SEC).
<i>Level 3 submenus</i>		
Primary Units (PRIMAR Parameter)		

Table 3-3. Format Menu Parameters

FORMAT Menu		
Parameter	Choices	Description
DECPNT	8888888 8888880 8888800 8.888888 88.88888 888.8888 8888.888 88888.88 888888.8	Decimal point location. Specifies the location of the decimal point or dummy zeroes in the primary unit display. Value should be consistent with local legal requirements.
DSPDIV	1D 2D 5D	Display divisions. Selects the minimum division size for the primary units displayed weight.
UNITS	LB KG G OZ TN T GN TROYOZ TROYLB LT NONE	Specifies primary units for displayed and printed weight. Values are: LB=pound; KG=kilogram; G=gram; OZ=ounce; TN=short ton; T=metric ton; GN=grain; TROYOZ=troy ounce; TROYLB=troy pound; LT=long ton. NOTE: Units sold outside North America are configured with KG for both primary and secondary units.
Secondary Units (SECNDR Parameter)		
DECPNT	888888.8 8888888 8888880 8888800 8.888888 88.88888 888.8888 8888.888 88888.88	Decimal point location. Determines the location of the decimal point or dummy zeros in the display.
DSPDIV	5D 1D 2D	Display divisions. Selects the value of minimum division size of the displayed weight.
UNITS	KG G OZ TN T GN TROYOZ TROYLB LT NONE LB	Specifies primary units for displayed and printed weight. Values are: LB=pound; KG=kilogram; G=gram; OZ=ounce; TN=short ton; T=metric ton; GN=grain; TROYOZ=troy ounce; TROYLB=troy pound; LT=long ton.
MULT	0.453592 <i>Enter other choices via keyboard</i>	Multiplier. Specifies the conversion factor by which the primary units are multiplied by to obtain the secondary units. The default is 0.453592, which is the conversion factor for changing pounds to kilograms. See Section 10.6 on page 65 for a list of multipliers. To toggle between primary and secondary units, press the UNITS key.

Table 3-3. Format Menu Parameters (Continued)

3.2.3 Calibration Menu

See Section 4.0 on page 33 for calibration procedures.

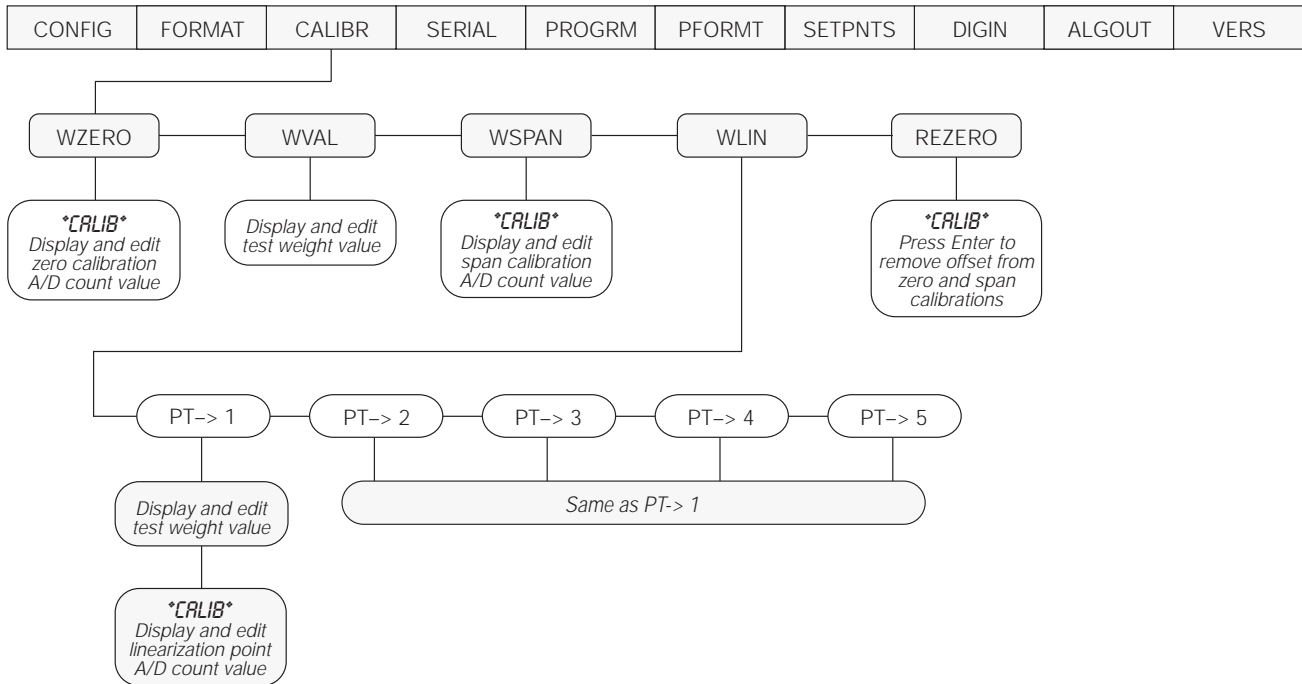

Figure 3-6. Calibration Menu

CALIBR Menu		
Parameter	Choices	Description
<i>Level 2 submenus</i>		
WZERO	—	Display and edit the zero calibration A/D count value.
WWAL	—	Display and edit the test weight value.
WSPAN	—	Display and edit the span calibration A/D count value.
WLIN	PT->1 — PT->5	Display and edit test weight and calibration values for up to five linearization points.
REZERO	—	Press Enter to remove an offset value from the zero and span calibrations.

Table 3-4. Calibration Menu Parameters

3.2.4 Serial Menu

See Section 10.3 on page 62 for information about IQ plus 710 serial data formats.

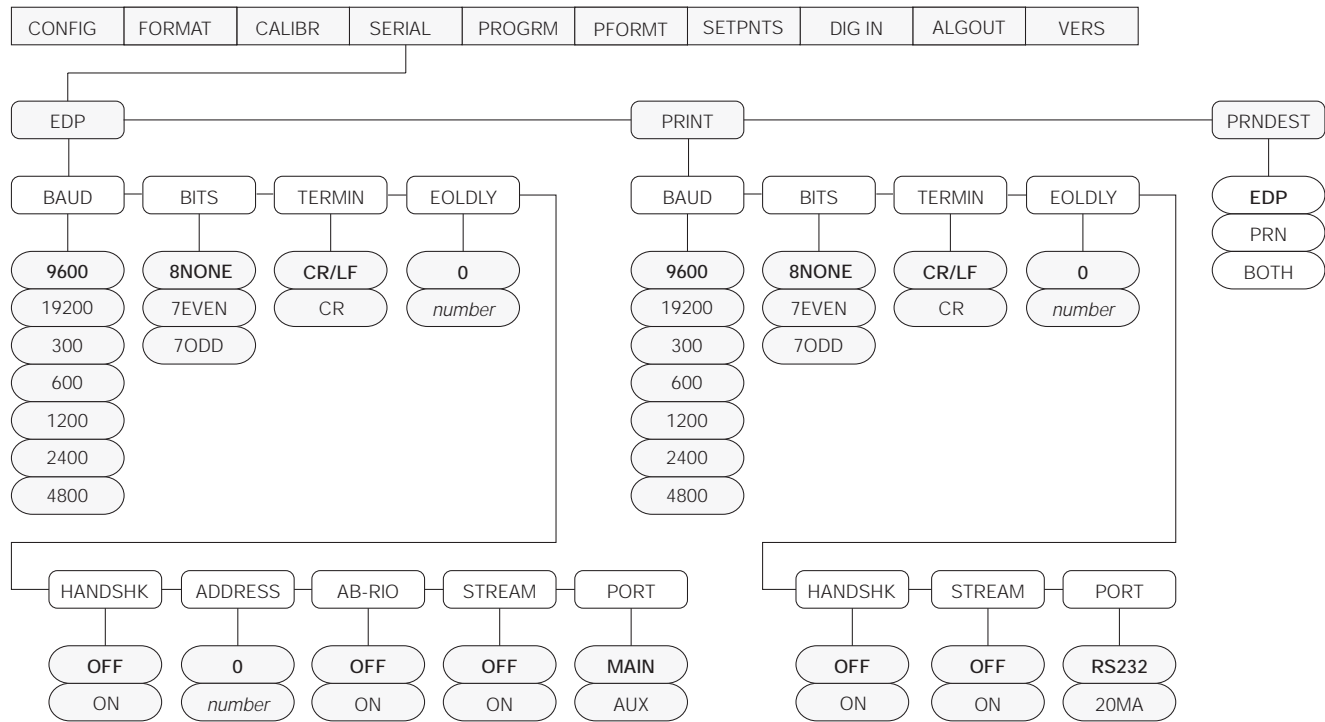

Figure 3-7. Serial Menu

SERIAL Menu		
Parameter	Choices	Description
<i>Level 2 submenus</i>		
EDP	BAUD BITS TERMIN EOLDLY HANDSHK ADDRESS AB-RIO STREAM PORT	Configure the EDP port. See Level 3 submenu parameter descriptions.
PRINT	BAUD BITS TERMIN EOLDLY HANDSHK STREAM PORT	Configure the printer port. See Level 3 submenu parameter descriptions.
PRNDEST	EDP PRN BOTH	Print destination. Selects the port for data transmission when the PRINT key is pressed or the KPRINT EDP command is sent.

Table 3-5. Serial Menu Parameters

SERIAL Menu		
Parameter	Choices	Description
Level 3 Submenus		EDP Port
BAUD	9600 19200 300 600 1200 2400 4800	Baud rate. Selects the transmission speed for the EDP port.
BITS	8NONE 7EVEN 7ODD	Selects number of data bits and parity of data transmitted from the EDP port.
TERMIN	CR/LF CR	Termination character. Selects termination character for data sent from the EDP port.
EOLDLY	0 <i>number</i>	End-of-line delay. Sets the delay period, in 0.1-second intervals, from when a formatted line is terminated to the beginning of the next formatted serial output. Value specified must be in the range 0-255, in tenths of a second (10 = 1 second).
HANDSHK	OFF ON	Specifies whether XON/XOFF flow control characters are used.
ADDRESS	0 <i>address</i>	Specifies the decimal indicator address for RS-485 connections. RS-232 communications is disabled if an address other than zero is specified for this parameter. RS-485 addresses must be in the range 01–255.
AB-RIO	OFF ON	Specifies whether the EDP uses the Allen-Bradley Remote I/O data stream. Specify ON only if the Remote I/O option is installed.
STREAM	OFF ON	Specifies whether data is streamed from the EDP port.
PORT	MAIN AUX	<i>Reserved for future use.</i>
Level 3 Submenus		Printer Port
BAUD	9600 19200 300 600 1200 2400 4800	Baud rate. Selects the transmission speed for the printer port.
BITS	8NONE 7EVEN 7ODD	Selects number of data bits and parity of data transmitted from the printer port.
TERMIN	CR/LF CR	Termination character. Selects termination character for data sent from the printer port.
EOLDLY	0 <i>number</i>	End-of-line delay. Sets the delay period, in 0.1-second intervals, from when a formatted line is terminated to the beginning of the next formatted serial output. Value specified must be in the range 0-255, in tenths of a second (10 = 1 second).
HANDSHK	OFF ON	Specifies whether XON/XOFF flow control characters are used.
STREAM	OFF ON	Specifies whether data is streamed from the printer port.
PORT	RS232 20MA	<i>Reserved for future use.</i>

Table 3-5. Serial Menu Parameters (Continued)

3.2.5 Program Menu

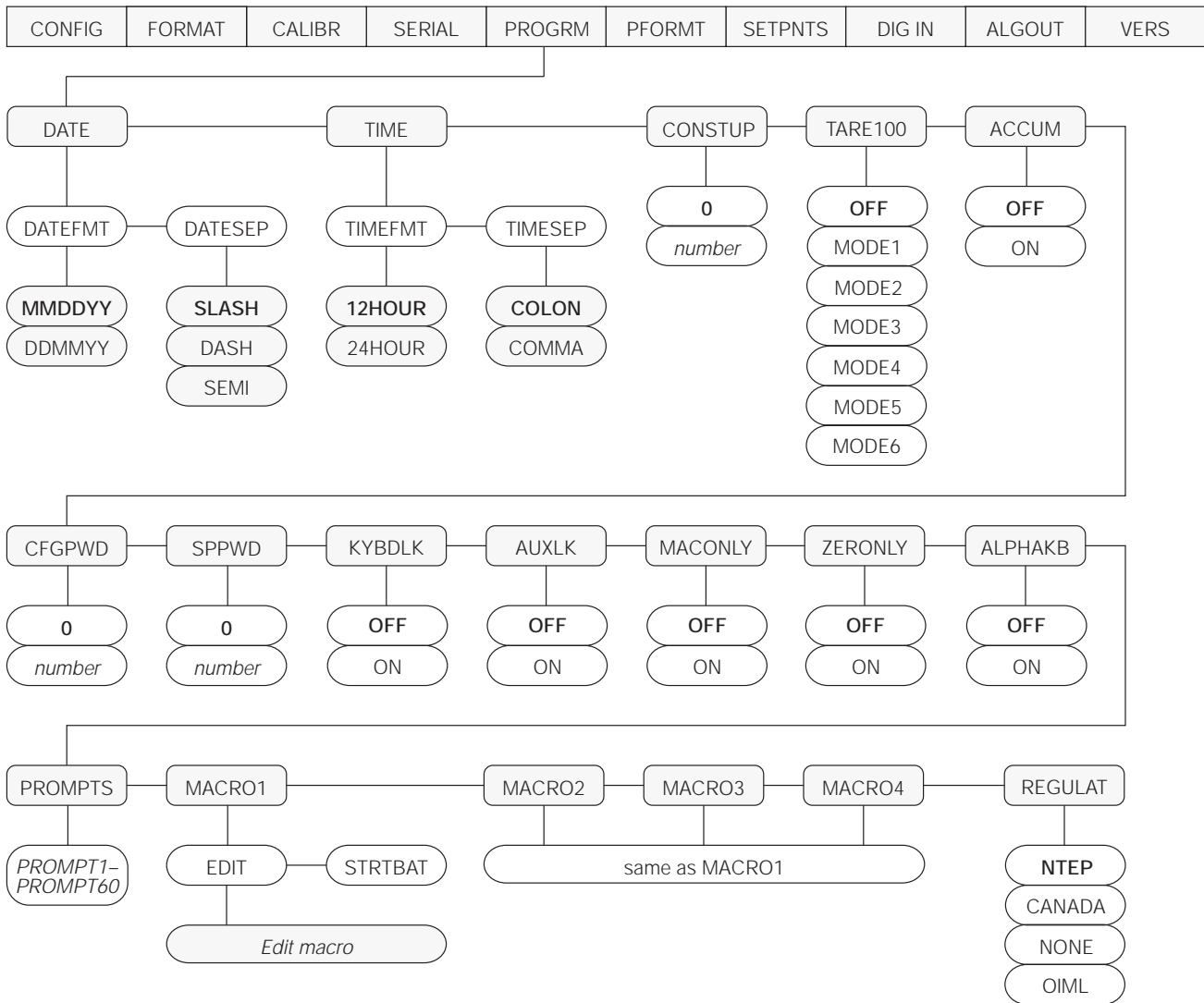

Figure 3-8. Program Menu

PROGRAM Menu		
Parameter	Choices	Description
<i>Level 2 submenus</i>		
DATE	DATEFMT DATESEP	Allows selection of date format and date separator character. See Level 3 submenu parameter descriptions. Use the TIME/DATE key or the SD EDP command to set the date. See Section 5.0 on page 36 for information about using the EDP commands.
TIME	TIMEFMT TIMESEP	Allows selection of time format and separator character. See Level 3 submenu parameter descriptions. Use the TIME/DATE key or the ST EDP command to set the date. See Section 5.0 on page 36 for information about using the EDP commands.

Table 3-6. Program Menu Parameters

PROGRM Menu		
Parameter	Choices	Description
CONSTUP	0 <i>number</i>	Specifies the initial consecutive number value used when the indicator is reset. Value specified must be in the range 0–9 999 999.
TARE100	OFF MODE1 MODE2 MODE3 MODE4 MODE5 MODE6	Specifies the truck mode used. If selected, the indicator switches from normal mode to the selected truck mode. See Section 7.0 on page 47 for more information about using the truck modes. MODE1: Auto clear ID, keyed tares, value swapping MODE2: Auto clear ID, no keyed tares, value swapping MODE3: Stored ID, keyed tares, value swapping MODE4: Stored ID, no keyed tares, value swapping MODE5: Stored ID, keyed tares, no value swapping MODE6: Stored ID, no keyed tares, no value swapping
ACCUM	OFF ON	Accumulator. Specifies whether the accumulator is enabled.
CFGPWD	0 <i>1–9999999</i>	Configuration password. Specify a non-zero value to restrict access to all configuration menus.
SPPWD	0 <i>1–9999999</i>	Setpoint password. Specify a non-zero value to restrict access to the setpoint menu.
KYBDLK	OFF ON	Keyboard lock. Specify ON to disable the keypad in normal mode.
AUXLK	OFF ON	Auxiliary keypad lock. Specify ON to disable all keys except ZERO, GROSS/NET, TARE, UNITS, and PRINT in normal mode.
MACONLY	OFF ON	Macro keys only. Specify ON to disable all except the four macro keys (F1–F4) in normal mode.
ZERONLY	OFF ON	Zero key only. Specify ON to disable all front panel keys except ZERO in normal mode.
ALPHAKB	OFF ON	Alpha keyboard. Specify ON to enable alpha entry for the indicator keypad. If OFF is specified, the ALPHA ENTRY key is disabled.
PROMPTS	<i>PROMPT1– PROMPT60</i>	Specify prompts for use in macros. Prompts are referenced by the NAME parameter under the MACRO submenu; prompts appear in the secondary display area during macro execution.
MACRO1 MACRO2 MACRO3 MACRO4	STRBAT EDIT	Specify MACROS 1–4. The STRBAT parameter can be set on to start a batch sequence on completion of the macro; the EDIT parameter contains up to 30 macro steps, including simulated keystrokes and pause/release conditions. See Section 9.0 on page 53 for more information about configuring macros.
REGULAT	NTEP OIML NONE CANADA	Regulatory mode. Specifies the regulatory agency having jurisdiction over the scale site. NONE allows entry of a zero tare, enabling use of net mode by batch routines. OIML and CANADA modes require the scale load to be at zero before clearing a tare; OIML mode replaces the <i>Gross</i> annunciator with <i>Brutto</i> .
Level 3 submenus		
DATEFMT	MMDDYY DDMMYY	Specifies the format used to display or print the date.
DATESEP	SLASH DASH SEMI	Specifies the date separator character.
TIMEFMT	12HOUR 24HOUR	Specifies the format used to display or print the time.
TIMESEP	COLON COMMA	Specifies the time separator character.

Table 3-6. Program Menu Parameters (Continued)

3.2.6 Print Format Menu

See Section 6.0 on page 43 for information about custom print formatting.

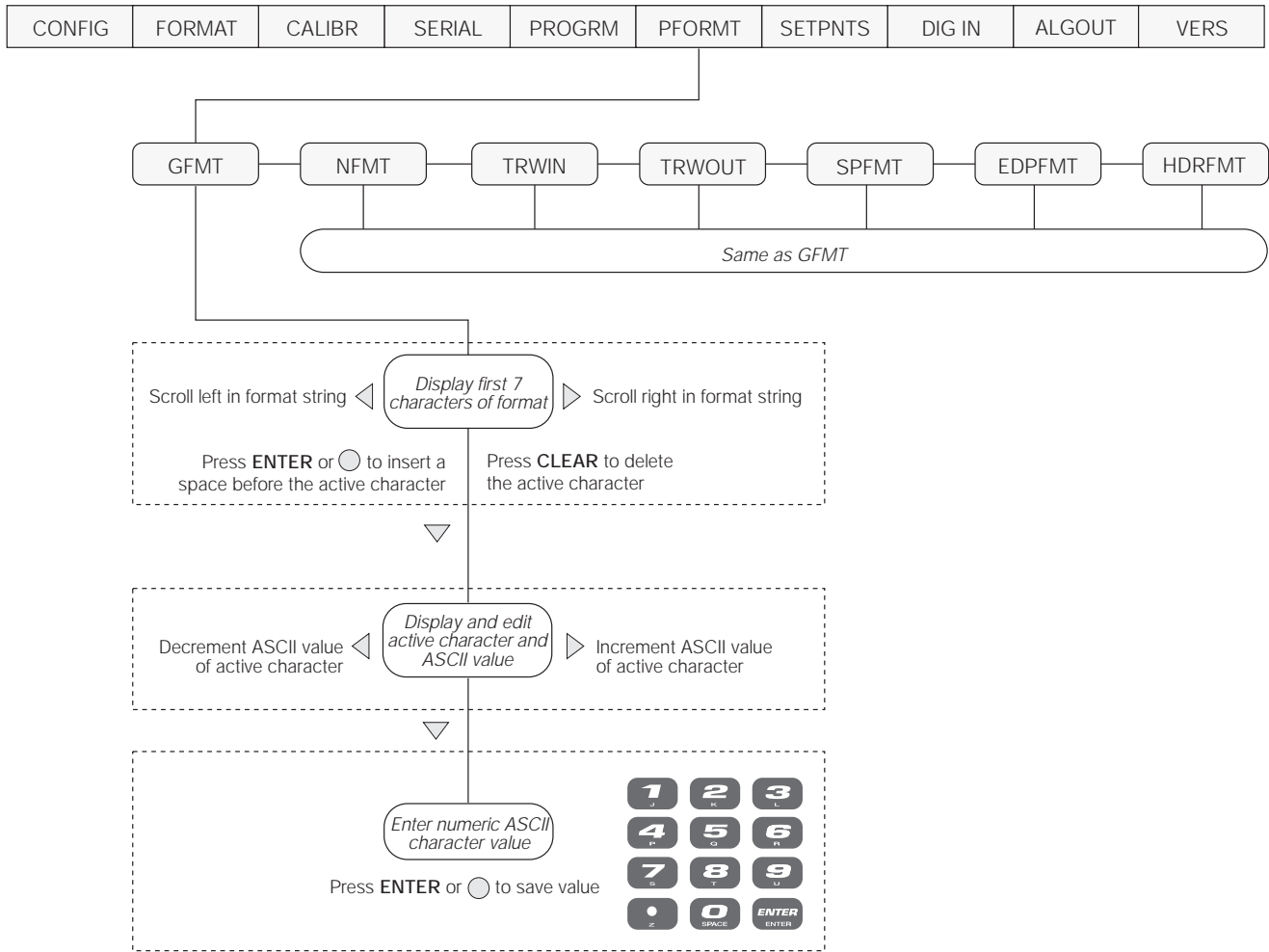

Figure 3-9. Print Format Menu

3.2.7 Setpoints Menu

See Section 8.0 on page 49 for more information about configuring and using setpoints.

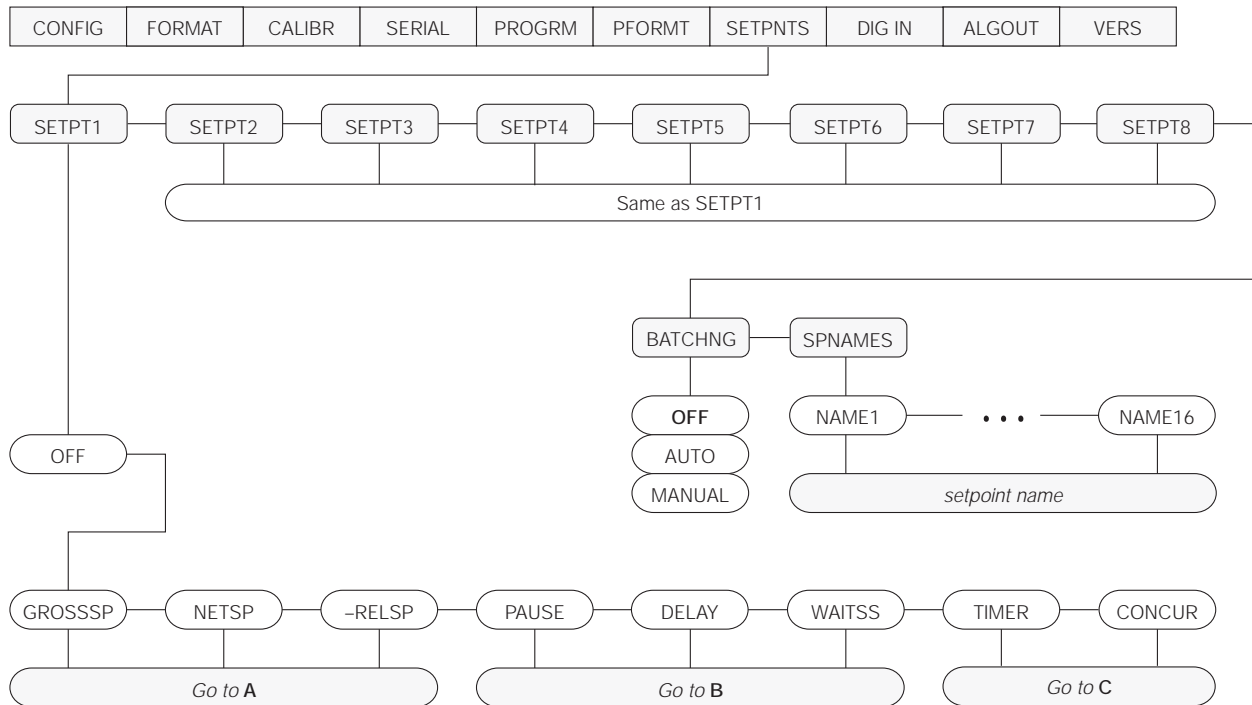

Figure 3-10. Setpoints Menu

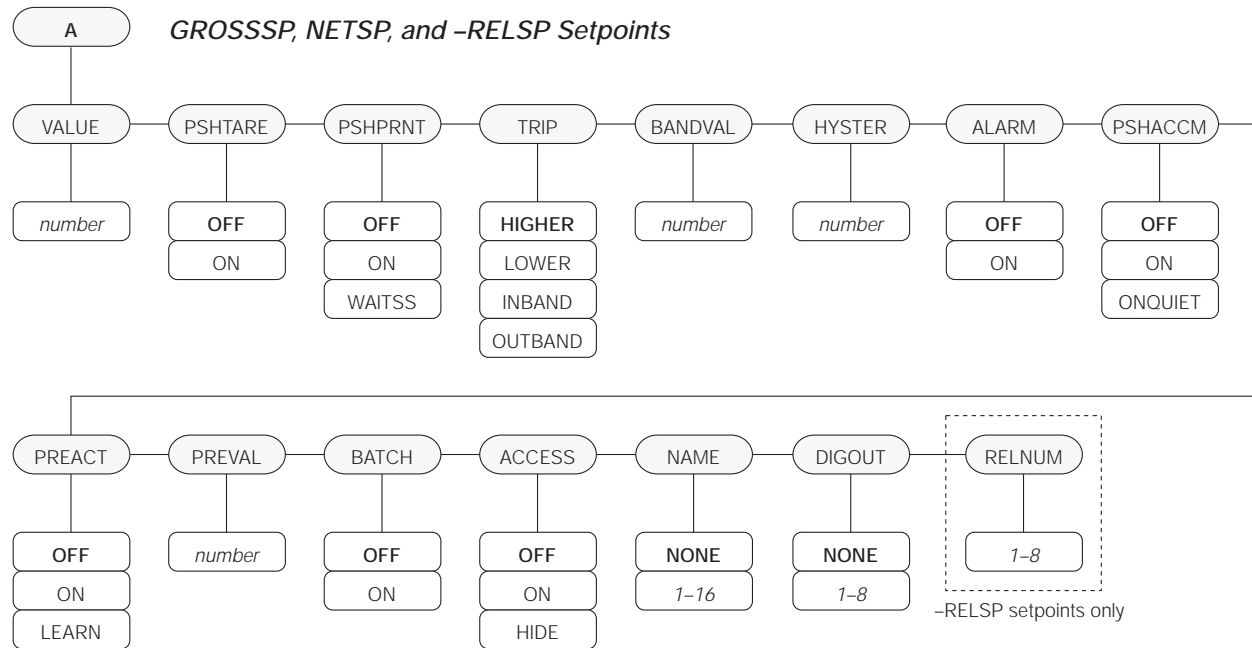

Figure 3-11. Submenu for GROSSSP, NETSP, and -RELSP Setpoints

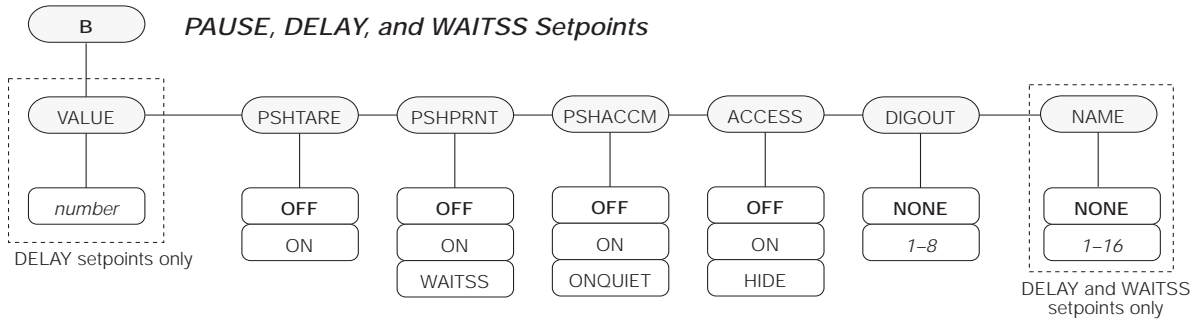

Figure 3-12. Submenu for PAUSE, DELAY, and WAITSS Setpoints

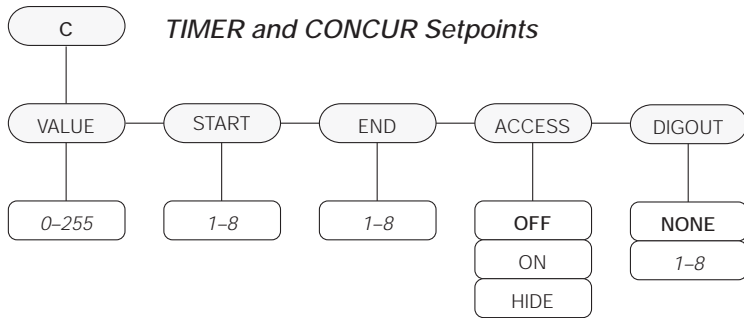

Figure 3-13. Submenu for TIMER and CONCUR Setpoints

SETPNTS Menu		
Parameter	Choices	Description
<i>Level 2 submenus</i>		
SETPT1-SETPT8	OFF GROSSSP NETSP -RELSP PAUSE DELAY WAITSS TIMER CONCUR	Specifies the setpoint kind. GROSSSP, NETSP, and -RELSP setpoint kinds can be used as either batch or continuous setpoints. PAUSE, DELAY, and WAITSS setpoint kinds can only be used in batch sequences. TIMER and CONCUR setpoint kinds can only be used as continuous setpoints. See Table 8-1 on page 50 for more information about setpoint kinds.
BATCHNG	OFF AUTO MANUAL	Batching enable. Set to AUTO or MANUAL to allow a batch sequence to run. MANUAL requires a BATSTRT digital input or STRTBAT macro configuration before the batch sequence can run. AUTO allows batch sequences to repeat continuously.
SPNAMES	NAME1-NAME16	Allows specification of up to 16 setpoint names. Names can be assigned to GROSSSP, NETSP, -RELSP, DELAY, and WAITSS setpoints.

Table 3-7. Setpoint Menu Parameters

SETPNTS Menu		
Parameter	Choices	Description
<i>Level 3 submenus</i>		
GROSSSP NETSP -RELSP	VALUE PSHTARE PSHPRNT TRIP BANDVAL HYSTER ALARM PSHACCM PREACT PREVAL BATCH ACCESS NAME DIGOUT RELNUM	Configure GROSSSP, NETSP, and -RELSP setpoints. See Level 4 parameter descriptions.
PAUSE DELAY WAITSS	PSHTARE PSHPRNT PSHACCM ACCESS DIGOUT NAME VALUE	Configure PAUSE, DELAY, and WAITSS setpoints. See Level 4 parameter descriptions.
TIMER CONCUR	VALUE START END ACCESS DIGOUT	Configure TIMER and CONCUR setpoints. See Level 4 parameter descriptions.
NAME1-NAME16	<i>name</i>	Specify up to 16 setpoint names. Names can be assigned to GROSSSP, NETSP, -RELSP, DELAY, and WAITSS setpoint types.
<i>Level 4 submenus</i>		
VALUE	<i>number</i>	GROSSSP, NETSP, -RELSP setpoint types: Specifies the target weight value. DELAY, TIMER, and CONCUR setpoint types: Specifies, in 0.1-second intervals, a time value in the range 0-65535.
PSHTARE	OFF ON	GROSSSP, NETSP, -RELSP, PAUSE, DELAY, and WAITSS setpoint types: Specify ON to perform an acquire tare operation when the setpoint is satisfied.
PSHPRNT	OFF ON WAITSS	GROSSSP, NETSP, -RELSP, PAUSE, DELAY, and WAITSS setpoint types: Specify ON to perform a print operation when the setpoint is satisfied; specify WAITSS to wait for standstill after setpoint is satisfied before printing.
PSHACCM	OFF ON ONQUIET	GROSSSP, NETSP, -RELSP, PAUSE, DELAY, and WAITSS setpoint types: Specify ON to update the accumulator and perform a print operation when the setpoint is satisfied. Specify ONQUIET to update the accumulator without printing.
TRIP	HIGHER LOWER INBAND OUTBAND	GROSSSP, NETSP, and -RELSP setpoint types: Specifies whether the setpoint is tripped when the weight is higher or lower than the setpoint value, within a band established around the value, or outside of that band. In a batch sequence with TRIP=HIGHER, the associated digital output is active until the setpoint value is reached or exceeded; with TRIP=LOWER, the output is active until the weight goes below the setpoint value.

Table 3-7. Setpoint Menu Parameters

SETPNTS Menu		
Parameter	Choices	Description
BANDVAL	<i>number</i>	GROSSSP, NETSP, and –RELSP setpoint types with TRIP=INBAND or OUTBAND: Specifies a weight equal to half the band width. The band established around the setpoint value is VALUE ±BANDVAL.
HYSTER	<i>number</i>	GROSSSP, NETSP, and –RELSP setpoint types: Specifies a band around the setpoint value that must be exceeded before the setpoint, once off, can trip on again.
ALARM	OFF ON	GROSSSP, NETSP, and –RELSP setpoint types: Specify ON to display the word <i>ALARM</i> on the primary display while the setpoint is active (batch setpoints) or while the setpoint is not tripped (continuous setpoints).
PREACT	OFF ON LEARN	GROSSSP, NETSP, and –RELSP setpoint types: Allows the digital output associated with a setpoint to shut off before the setpoint is satisfied to allow for material in suspension. The ON value adjusts the setpoint value up or down (depending on the TRIP parameter value) from the setpoint value. The LEARN value can be used to automatically adjust the preact value after each batch. LEARN compares the actual weight at standstill to the target setpoint value, then adjusts the preact by half of the difference after each batch.
PREVAL	<i>number</i>	GROSSSP, NETSP, and –RELSP setpoint types: Specifies the preact value for setpoints with Preact set to ON or LEARN. Depending on the TRIP value specified for the setpoint, the setpoint trip value is adjusted up or down by the preact value.
BATCH	OFF ON	GROSSSP, NETSP, and –RELSP setpoint types: Specifies whether the setpoint is used as a batch (ON) or continuous (OFF) setpoint.
ACCESS	OFF ON HIDE	All setpoint types: Specifies whether the SETPOINT key can be used to change the setpoint value in normal mode, including macro simulations of pressing the SETPOINT key. ON: Value can be displayed and changed OFF: Value can be displayed but not changed HIDE: Value cannot be displayed or changed
NAME	NONE, 1–16	GROSSSP, NETSP, –RELSP, DELAY, and WAITSS setpoint types: Specify the number of an assigned setpoint name.
DIGOUT	NONE, 1–8	All setpoint types: Specifies a digital output associated with the setpoint. For continuous setpoints, the digital output is turned on when the condition is met; for batch setpoints, the digital output is on <i>until</i> the setpoint condition is met.
RELNUM	1–8	–RELSP setpoints: Specifies the number of the relative setpoint. The target weight for this setpoint is the setpoint value of the relative setpoint minus the setpoint value of this setpoint.
START	1–8	TIMER and CONCUR setpoint types: Specifies the starting setpoint number. <i>Do not</i> specify the number of the TIMER or CONCUR setpoint itself. The TIMER or CONCUR setpoint begins monitoring when the starting setpoint begins.
END	1–8	TIMER and CONCUR setpoint types: Specifies the ending setpoint number. <i>Do not</i> specify the number of the TIMER or CONCUR setpoint itself. The TIMER or CONCUR setpoint stops monitoring when the ending setpoint begins.

Table 3-7. Setpoint Menu Parameters

3.2.8 Digital Input Menu

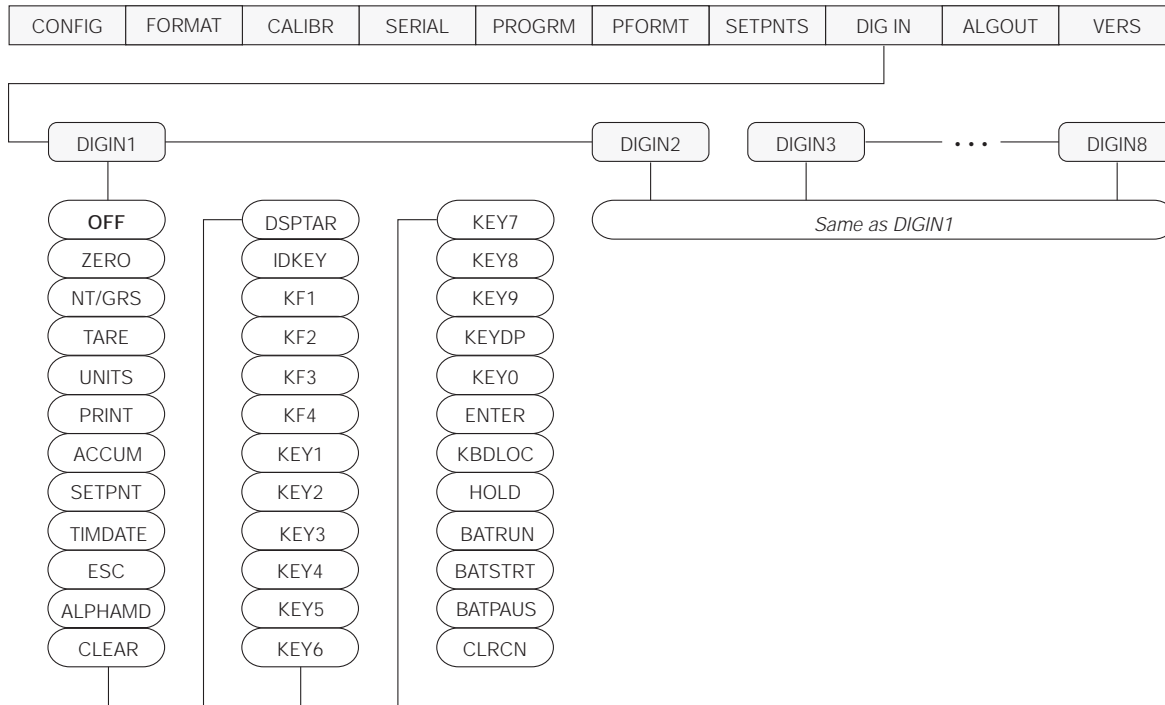

Figure 3-14. Digital Input Menu

DIG IN Menu		
Parameter	Choices	Description
<i>Level 2 submenus</i>		
DIGIN1 DIGIN2 DIGIN3 DIGIN4 DIGIN5 DIGIN6 DIGIN7 DIGIN8	OFF ZERO NT/GRS TARE UNITS PRINT ACCUM SETPNT TIMDATE ESC ALPHAMD CLEAR DSPTAR IDKEY KF1—KF4 KEY0—KEY9 KEYDP ENTER BATRUN BATSTRT BATPAUS KBDLOC HOLD CLRCN	Specifies the function activated by digital inputs 1–8. <ul style="list-style-type: none"> • ZERO, NT/GRS (net/gross mode toggle), TARE, UNITS, and PRINT provide the same functions as the five major front panel keys. • ACCUM, SETPNT, TIMDATE, ESC, ALPHAMD, CLEAR, DSPTAR, and IDKEY provide the same functions as the front panel keys. • KF1—KF4 are equivalent to pressing the macro keys, F1—F4. • KEY0—KEY9 and KEYDP (decimal point) are simulate pressing keys on the numeric keypad. • ENTER simulates pressing the front panel ENTER key. • BATRUN allows a batch routine to be started and run. With BATRUN on (low), the BATSTRT input starts the batch; if BATRUN is off (high), BATSTRT cancels the batch. • BATSTRT starts or ends a batch routine, depending on the state of the BATRUN input. • BATPAUS pauses a batch routine. • KBDLOC locks the keyboard (indicator front panel). • HOLD holds the current display. Releasing this input clears the running average filter. • CLRCN resets the consecutive number to the value specified on the CONSTUP parameter (PROGRM menu).

Table 3-8. Digital Input Menu Parameters

3.2.9 Analog Output Menu

The ALGOUT menu is used only if the analog output option is installed. If the analog output option is installed, configure all other indicator functions and calibrate the indicator before configuring the analog output. See Section 10.7 on page 67 for analog output calibration procedures.

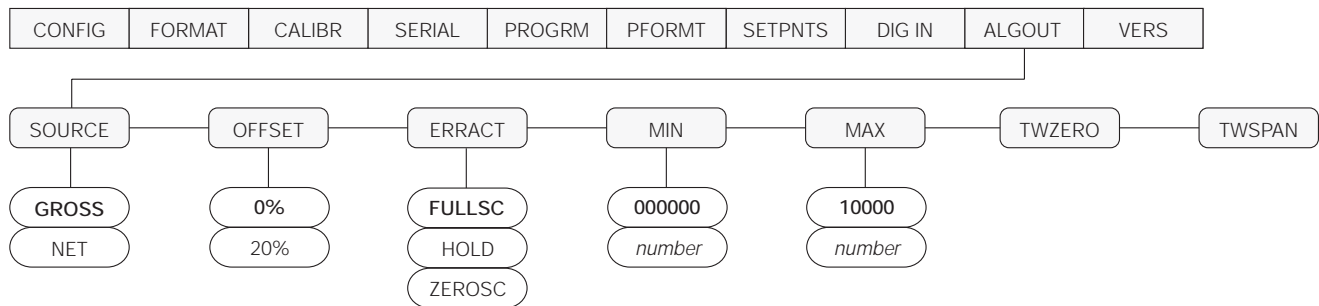

Figure 3-15. Analog Output Menu

ALG OUT Menu		
Parameter	Choices	Description
<i>Level 2 submenus</i>		
SOURCE1	GROSS NET	Specifies the source tracked by the analog output.
OFFSET	0% 20%	Zero offset. Selects whether the analog output supplies voltage (0–10 V) or current (4–20 mA) output. Select 0% for 0–10 V output; select 20% for 4–20 mA output.
ERRACT	FULLSC HOLD ZEROSC	Error action. Specifies how the analog output responds to system error conditions. Possible values are: FULLSC: Set to full value (10 V or 20 mA) HOLD: Hold current value ZEROSC: Set to zero value (0 V or 4 mA)
MIN	000000 number	Specifies the minimum weight value tracked by the analog output. Specify a value in the range 0–9999800.
MAX	010000 number	Specifies the maximum weight value tracked by the analog output. Specify a value in the range 0–9999800
TWZERO	—	Tweak zero. Adjust the analog output zero calibration. Use a multimeter to monitor the analog output value. Press and hold Δ or ∇ to adjust the output.
TWSPAN	—	Tweak span. Adjust the analog output span calibration. Use a multimeter to monitor the analog output value. Press and hold Δ or ∇ to adjust the output.

Table 3-9. Analog Output Menu Parameters

3.2.10 Version Menu

The VERS menu is used to check the software version installed in the indicator. There are no parameters associated with the Version menu: when selected, the indicator displays the installed software version number.

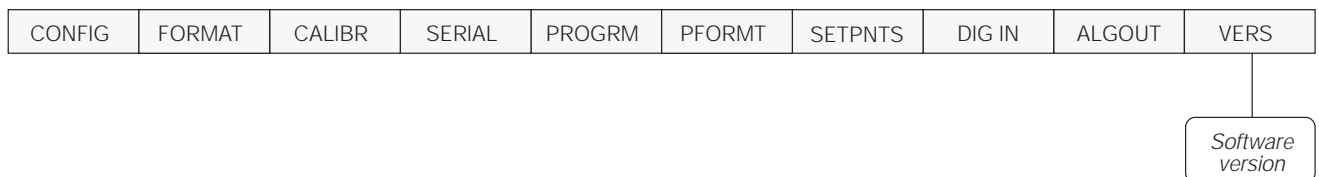

Figure 3-16. Version Menu

4.0 Calibration

The IQ plus 710 can be calibrated using the front panel, EDP commands, or the Revolution™ Scaleware configuration utility. Each method consists of the following steps:

- Zero calibration
- Entering the test weight value
- Span calibration
- Optional five-point linearization
- Optional rezero calibration for test weights using hooks or chains.

The following sections describe the calibration procedure for each of the calibration methods.

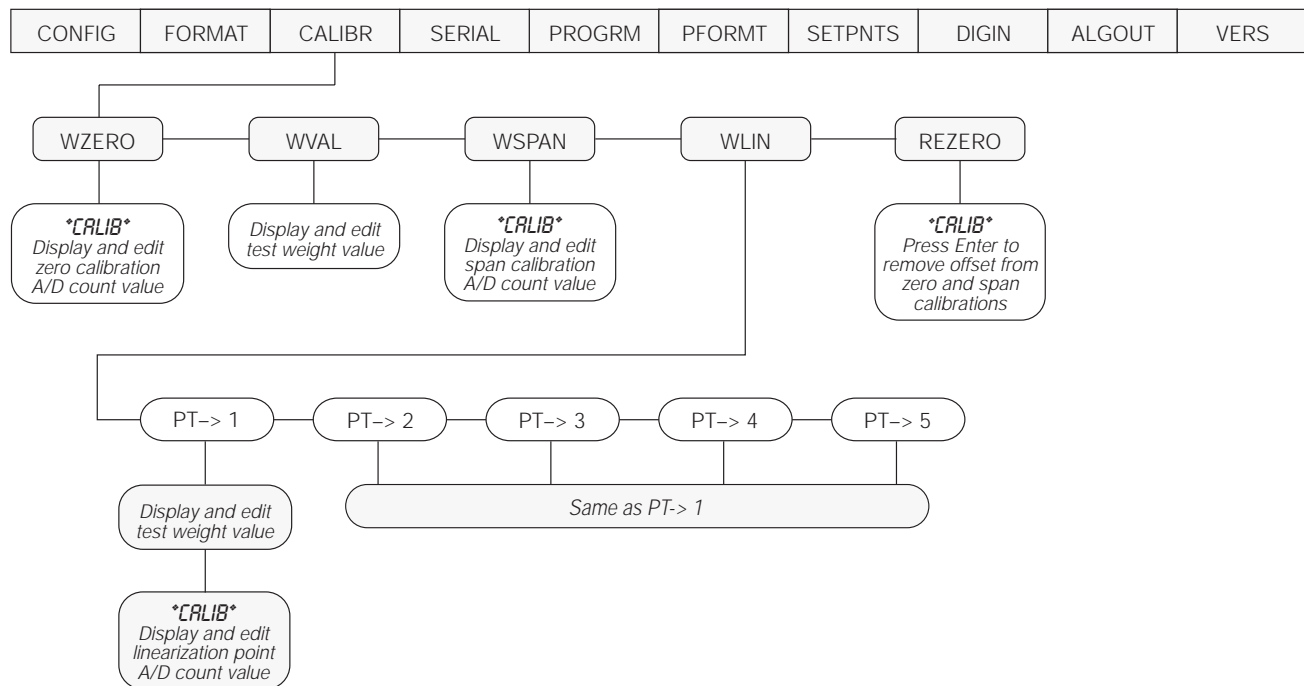

Figure 4-1. Calibration (CALIBR) Menu

4.1 Front Panel Calibration

To calibrate the indicator using the front panel, do the following:

1. Place the indicator in setup mode (display reads *CONFIG*) and remove all weight from the scale platform. If your test weights require hooks or chains, place the hooks or chains on the scale for zero calibration.
2. Press \blacktriangleright until the display reads *CALIBR* (see Figure 4-1). Press ∇ to go to zero calibration (*WZERO*).
3. With *WZERO* displayed, press \bigcirc to calibrate zero. The indicator displays **CAL** while calibration is in progress. When complete, the A/D count for the zero calibration is displayed. Press \bigcirc again to save the zero calibration value and go to the next prompt (*WVAL*).
4. With *WVAL* displayed, place test weights on the scale and press \bigcirc to show the test weight value. Use the numeric keypad to enter the actual test weight, then press **ENTER** to save the value and go to span calibration (*WSPAN*).
5. With *WSPAN* displayed, press \bigcirc to calibrate span. The indicator displays **CAL** while calibration is in progress. When complete, the A/D count for the span calibration is displayed. Press \bigcirc again to save the span calibration value and go to the next prompt (*WLIN*).
6. Five-point linearization (using the *WLIN* parameter) provides increased scale accuracy by calibrating the indicator at up to five additional points between the zero and span calibrations.

Linearization is optional: if you choose not to perform linearization, skip the `WLIN` parameter; if linearization values have previously been entered, use the numeric keypad to set each point to zero and press `ENTER`. To perform linearization, follow the procedure below:

With `WLIN` displayed, Press `▽` to go to the first linearization point (`PT-> 1`). Place test weights on the scale and press `○` or `ENTER`. Use the numeric keypad to enter the actual test weight value, then press `ENTER` to calibrate. The indicator displays `*CAL*` while calibration is in progress. When complete, the A/D count for the linear calibration is displayed. Press `ENTER` again to save the calibration value and go to the next prompt (`PT-> 2`).

Repeat for up to five linearization points. To exit the linearization parameters, press `△` to return to `WLIN`.

7. The optional rezero function is used to remove a calibration offset when hooks or chains are used to hang the test weights.
 - If no other apparatus was used to hang the test weights during calibration, remove the test weights and press `△` to return to the `CALIBR` menu.
 - If hooks or chains were used during calibration, remove these and the test weights from the scale. With all weight removed, press `ENTER` to rezero the scale. This function adjusts the zero and span calibration values. The indicator displays `*CAL*` while the zero and span calibrations are adjusted. When complete, the adjusted A/D count for the zero calibration is displayed. Press `ENTER` to save the value, then press `△` to return to the `CALIBR` menu.
8. Press `◀` until the display reads `CONFIG`, then press `△` to exit setup mode.

4.2 EDP Command Calibration

To calibrate the indicator using EDP commands, the indicator EDP port must be connected to a terminal or personal computer. See Section 2.3.2 on page 6 for EDP port pin assignments; see Section 5.0 on page 36 for more information about using EDP commands.

Once the indicator is connected to the sending device, do the following:

1. Place the indicator in setup mode (display reads `CONFIG`) and remove all weight from the scale platform. If your test weights require hooks or chains, place the hooks or chains on the scale for zero calibration.
2. Send the `WZERO` EDP command to calibrate zero. The indicator displays `*CAL*` while calibration is in progress.
3. Place test weights on the scale and use the `WVAL` command to enter the test weight value in the following format:
`WVAL=nnnnn<CR>`
4. Send the `WSPAN` EDP command to calibrate span. The indicator displays `*CAL*` while calibration is in progress.

5. Up to five linearization points can be calibrated between the zero and span calibration values. Use the following commands to set and calibrate a single linearization point:

```
WLIN.V1=nnnnn<CR>
WLIN.C1<CR>
```

The `WLIN.V1` command sets the test weight value (`nnnnn`) for linearization point 1. The `WLIN.C1` command calibrates the point. Repeat using the `WLIN.Vx` and `WLIN.Cx` commands as required for additional linearization points.

6. To remove an offset value, clear all weight from the scale, including hooks or chains used to hang test weights, then send the `REZERO` EDP command. The indicator displays `*CAL*` while the zero and span calibrations are adjusted.
7. Send the `KUPARROW` or `KEXIT` EDP command to exit setup mode.

4.3 Revolution™ Scaleware Calibration

To calibrate the indicator using Revolution Scaleware, the indicator EDP port must be connected to a PC running the Revolution configuration utility.

Use the following procedure to calibrate the indicator:

1. Select *Calibrate Indicator* from the Revolution Scaleware main menu.
2. On the Indicator Calibration display, select the indicator model (*IQ+710*) and communications port then click *OK*.
3. Revolution Scaleware uploads calibration data from the indicator then presents the information in a display like that shown in Figure 4-2.

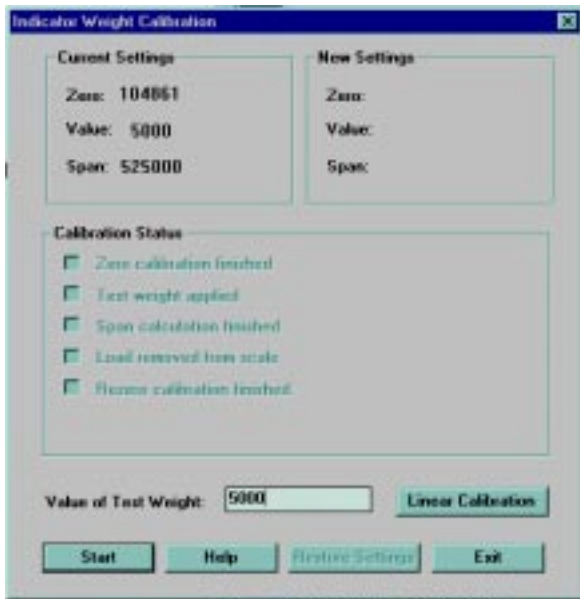

Figure 4-2. Revolution Scaleware Calibration Display

4. Enter the *Value of Test Weight* to be used for span calibration then click *OK*.
5. The Zero Calibration dialog box prompts you to remove all weight from the scale. Clear the scale and click *OK* to begin zero calibration. **NOTE:** If your test weights require hooks or chains, place the hooks or chains on the scale for zero calibration.
6. When zero calibration is complete, the Span Calibration dialog box prompts you to place test weights on the scale for span calibration. Place test weights on the scale then click *OK*.
7. When span calibration is complete, the Rezero dialog box prompts you to remove weights from the scale. Remove the weights then click *OK*.
8. When calibration is complete, the *New Settings* fields of the Indicator Calibration display are filled in. Click *Exit* to save the new values and return to the Revolution Scaleware main menu; to restore the previous calibration values, click *Restore Settings*.

5.0 EDP Commands

The IQ plus 710 indicator can be controlled by a personal computer or remote keyboard connected to the indicator EDP port. Control is provided by a set of EDP commands that can simulate front panel key press functions, display and change setup parameters, and perform reporting functions. The EDP port provides the capability to print configuration data or to save that data to an attached personal computer. This section describes the EDP command set and procedures for saving and transferring data using the EDP port.

5.1 The EDP Command Set

The EDP command set can be divided into five groups: key press commands, reporting commands, the RESETCONFIGURATION special function command, parameter setting commands, and transmit weight data commands.

When the indicator processes an EDP command, it responds with the message *OK*. The *OK* response verifies that the command was received and has been executed. If the command is unrecognized or cannot be executed, the indicator responds with *??*.

The following sections list the commands and command syntax used for each of these groups.

5.1.1 Key Press Commands

Key press EDP commands (see Table 5-1) simulate pressing the keys on the front panel of the indicator. These commands can be used in both setup and weighing mode. Several of the commands serve as “pseudo” keys, providing functions that are not represented by a key on the front panel.

For example, to enter a 15-pound tare weight using EDP commands:

1. Type K1 and press ENTER (or RETURN).
2. Type K5 and press ENTER.
3. Type KTARE and press ENTER.

Command	Function
KZERO	Press the ZERO key
KGROSSNET	Press the GROSS/NET key
KGROSS	Go to gross mode (pseudo key)
KNET	Go to net mode (pseudo key)
KTARE	Press the TARE key
KUNITS	Press the UNITS key
KPRIM	Go to primary units (pseudo key)

Table 5-1. EDP Key Press Commands

Command	Function
KSEC	Go to secondary units (pseudo key)
KPRINT	Press the PRINT key
KNEWID	Press the ID key
KSETPOINT	Press the SETPOINT key
KTIMEDATE	Press the TIME/DATE key
KTIME	Display time (pseudo key)
KDATE	Display date (pseudo key)
KESCAPE	Press the ESCAPE key
KALPHA	Press the ALPHA ENTRY key
KDISPACCUM	Press the ACCUM key
KDISPTARE	Press the DISPLAY TARE key
KCLR	Press the CLEAR key
KCLRNCN	Reset consecutive number (pseudo key)
KLEFTARROW	In setup mode, move left in the menu; in weighing mode, press the UNITS key
KRIGHTARROW	In setup mode, move right in the menu; in weighing mode, press the PRINT key
KUPARROW	In setup mode, move up in the menu; in weighing mode, press the ZERO key
KDOWNARROW	In setup mode, move down in the menu; in weighing mode, press the GROSS/ NET key
KEXIT	In setup mode, exits to normal mode
K0	Press number 0 (zero)
K1	Press number 1
K2	Press number 2
K3	Press number 3
K4	Press number 4
K5	Press number 5
K6	Press number 6
K7	Press number 7
K8	Press number 8
K9	Press number 9
KDOT	Press the decimal point (.)
KENTER	Press the ENTER key
KF1	Play MACRO1
KF2	Play MACRO2
KF3	Play MACRO3
KF4	Play MACRO4

Table 5-1. EDP Key Press Commands (Continued)

5.1.2 Reporting Commands

Reporting commands (see Table 5-2) send specific information to the EDP port. These commands can be used in both setup mode and normal mode.

Command	Function
DUMPALL	List all parameter values
VERSION	Write IQ plus 710 software version
P	Write current displayed weight with units identifier. See Section 10.2 on page 61 for more information.
S	Write one frame of stream format

Table 5-2. EDP Reporting Commands

5.1.3 The RESETCONFIGURATION Command

The RESETCONFIGURATION command can be used to restore all configuration parameters to their default values. Before issuing this command, the indicator must be placed in test mode (press and hold setup switch for approximately three seconds).

This command is equivalent to using the DEFAULT function in TEST mode. See Section 10.8 on page 67 for more information about test mode. **NOTE:** All load cell calibration settings are lost when the RESETCONFIGURATION command is run.

5.1.4 Parameter Setting Commands

Parameter setting commands allow you to display or change the current value for a particular configuration parameter (Tables 5-3 through 5-11).

Current configuration parameter settings can be displayed in either setup mode or normal mode using the following syntax:

`command<ENTER>`

Most parameter values can be changed in setup mode only; setpoint parameters listed in Table 5-8 on page 40 can be changed when in normal weighing mode.

Use the following command syntax when changing parameter values:

`command=value<ENTER>`

where *value* is either a number or a parameter value. Use no spaces before or after the equal (=) sign. If you type an incorrect command, the display reads ??.

For example, to set the motion band parameter to 5, type the following:

`MOTBAND=5D<ENTER>`

Command	Description	Values
GRADS	Graduations	1-100000
ZTRKBND	Zero track band	OFF, 0.5D, 1D, 3D
ZRANGE	Zero range	1.9%, 100%
MOTBAND	Motion band	1D, 2D, 3D, 5D, 10D, 20D, OFF
OVRLOAD	Overload	FS+2%, FS+1D, FS+9D, FS
DIGFLTR	Digital filtering	1, 2, 4, 8, 16, 32, 64, 128, 256, 1RT, 2RT, 4RT, 8RT, 16RT, 32RT, 64RT, 128RT, 256RT
DFSNS	Digital filter cutout sensitivity	2OUT, 4OUT, 8OT, 16OUT, 32OUT, 64OUT, 128OUT
DFTHRH	Digital filter cutout threshold	NONE, 2DD, 5DD, 10DD, 20DD, 50DD, 100DD, 200DD, 250DD
PWRUPMD	Power up mode	GO, DELAY
TAREFN	Tare function	BOTH, NOTARE, PBTARE, KEYED

Table 5-3. CONFIG EDP Commands

Command	Description	Values
PRI.DECPNT	Primary units decimal position	8.888888, 88.888888, 888.8888, 8888.888, 88888.88, 888888.8, 88888888, 88888880, 88888800
PRI.DSPDIV	Primary units display divisions	1D, 2D, 5D
PRI.UNITS	Primary units	LB, KG, G, OZ, TN, T, GN, TROYOZ, TROYLB, LT, NONE

Table 5-4. FORMAT EDP Commands

Command	Description	Values
SEC.DECPNT	Secondary units decimal position	8.888888, 88.888888, 888.8888, 8888.888, 88888.88, 888888.8, 8888888, 8888880, 8888800
SEC.DSPDIV	Secondary units display divisions	1D, 2D, 5D
SEC.UNITS	Secondary units	LB, KG, G, OZ, TN, T, GN, TROYOZ, TROYLB, LT, NONE
SEC.MULT	Secondary units multiplier	0.00000–99999.99
DECFMT	Decimal format	DOT, COMMA
DSPRATE	Display rate	250MS, 500MS, 750MS, 1500MS, 2SEC, 2500MS, 3SEC, 4SEC, 6SEC, 8SEC

Table 5-4. FORMAT EDP Commands (Continued)

Command	Description	Values
WZERO	Zero calibration	—
WVAL	Test weight value	<i>test_weight_value</i>
WSPAN	Span calibration	—
WLIN.F1–WLIN.F5	Actual raw count value for linearization points 1–5	—
WLIN.V1–WLIN.V5	Test weight value for linearization points 1–5	<i>test_weight_value</i>
WLIN.C1–WLIN.C5	Calibrate linearization points 1–5	—
REZERO	Rezero	—
LC.CD	Set deadload coefficient	<i>value</i>
LC.CW	Set span coefficient	<i>value</i>

Table 5-5. CALIBR EDP Commands

Command	Description	Values
EDP.BAUD	EDP port baud rate	300, 600, 1200, 2400, 4800, 9600, 19200
EDP.BITS	EDP port data bits/parity	8NONE, 7EVEN, 7ODD
EDP.TERMIN	EDP port termination character	CR/LF, CR
EDP.EOLDLY	EDP port end-of-line delay	0–255 (0.1-second intervals)
EDP.HANDSHK	EDP port handshaking	OFF, ON
EDP.ADDRESS	EDP port RS-485 address	0, 01–255
EDP.AB-RIO	EDP port Remote I/O stream	OFF, ON
EDP.STREAM	EDP port streaming	OFF, ON
PRN.BAUD	Printer port baud rate	300, 600, 1200, 2400, 4800, 9600, 19200
PRN.BITS	Printer port data bits/parity	8NONE, 7EVEN, 7ODD
PRN.TERMIN	Printer port termination character	CR/LF, CR
PRN.EOLDLY	Printer port end-of-line delay	0–255 (0.1-second intervals)
PRN.HANDSHK	Printer port handshaking	OFF, ON
PRN.STREAM	Printer port streaming	OFF, ON
PRNDEST	Print destination	EDP, PRN, BOTH

Table 5-6. SERIAL EDP Commands

Command	Description	Values
SD	Set date	<i>MMDDYY</i> or <i>DDMMYY</i> (enter using DATEFMT specified)
ST	Set time	<i>hhmm</i> (enter using 24-hour format)
DATEFMT	Date format	MMDDYY, DDMMYY
DATESEP	Date separator	SLASH, DASH, SEMI
TIMEFMT	Time format	12HOUR, 24HOUR
TIMESEP	Time separator	COLON, COMMA
CONSTUP	Consecutive number start-up value	<i>0-999 999</i>
TARE100	Truck in/out mode	OFF, MODE1, MODE2, MODE3, MODE4, MODE5, MODE6
ACCUM	Accumulator	OFF, ON
CFGPWD	Configuration password	<i>0, 1-9999999</i>
SPPWD	Setpoint password	<i>0, 1-9999999</i>
KYBDLK	Keyboard lock (disable keypad)	OFF, ON
AUXLK	Disable auxiliary keyboard	OFF, ON
MACONLY	Disable all except macro keys	OFF, ON
ZERONLY	Disable all keys except ZERO	OFF, ON
ALPHAKB	Enable ALPHA ENTRY key	OFF, ON
REGULAT	Regulatory compliance	NONE, OIML, NTEP, CANADA
PROMPT#1- PROMPT#60	Macro prompt	See Section 9.0 on page 53 for information about macro programming
MACRO1.K01- MACRO1.K30	Set MACRO1 keystroke	
MACRO2.K01- MACRO2.K30	Set MACRO2 keystroke	
MACRO3.K01- MACRO3.K30	Set MACRO3 keystroke	
MACRO4.K01- MACRO4.K30	Set MACRO4 keystroke	

Table 5-7. PROGRM EDP Commands

Command	Description	Values
SETPOINT	Setpoint number	1-8
KIND	Setpoint kind	OFF, GROSSSP, NETSP, -RELSP, PAUSE, DELAY, WAITSS, TIMER, CONCUR
VALUE	Setpoint value	<i>number</i>
PSHTARE	Push tare	OFF, ON
PSHPRINT	Push print	OFF, ON, WAITSS
PSHACCM	Push accumulate	OFF, ON, ONQUIET
TRIP	Trip	HIGHER, LOWER, INBAND, OUTBAND
BANDVAL	Band value	<i>number</i>
HYSTER	Hysteresis	<i>number</i>
ALARM	Alarm	OFF, ON
PREACT	Preact	OFF, ON, LEARN
PREVAL	Preact value	<i>number</i>
BATCH	Batch step enable	OFF, ON
NAME	Setpoint name number	NONE, 1-16
ACCESS	Setpoint access	OFF, ON, HIDE
DIGOUT	Digital output	NONE, 1-8
RELNUM	Relative setpoint numer	1-8
START	Starting setpoint	1-8
END	Ending setpoint	1-8
BATCHNG	Batching mode	OFF, AUTO, MANUAL
SPNAME#1— SPNAME#16	Setpoint names	<i>name</i>

Table 5-8. SETPNTS EDP Commands

Command	Description	Values
GFMT	Gross demand print format string	See Section 6.0 on page 43 for detailed information
NFMT	Net demand print format string	
SPFMT	Setpoint print format string	
TRWIN	Truck weigh-in print format string	
TRWOUT	Truck weigh-out print format string	
EDPFMT	EDP demand print format string	
HDRFMT	Ticket header format string	

Table 5-9. PFORMT EDP Commands

Command	Description	Values
DIGIN1 DIGIN2 DIGIN3 DIGIN4 DIGIN5 DIGIN6 DIGIN7 DIGIN8	Digital input function	OFF, ZERO, NT/GRS, TARE, UNITS, PRINT, ACCUM, SETPNT, TIMDATE, ESC, ALPHAMD, CLEAR, DSPTAR, IDKEY, KF1-KF4, KEY0-KEY9, KEYDP, ENTER, BATRUN, BATSTRT, BATPAUS, KBDLOC, HOLD, CLRCN

Table 5-10. DIG IN EDP Commands

Command	Description	Values
SOURCE1	Analog output source	GROSS, NET
OFFSET	Zero offset	0%, 20%
ERRACT	Error action	FULLSC, HOLD, ZEROSC
MIN	Minimum value tracked	0-9 999 800
MAX	Maximum value tracked	0-9 999 800
ZERO1	Zero calibration	0-16 383
SPAN1	Span calibration	0-16 383

Table 5-11. ALGOUT EDP Commands

5.1.5 Normal Mode Commands

The normal mode commands (see Table 5-12) transmit data to the EDP port on demand. These commands are valid only in normal operating mode.

Command	Description	Response Format
CONSNUM	Set consecutive number	0-999 999
SD	Set date	MMDDYY or DDMMYY (enter using DATEFMT specified)
ST	Set time	hhmm (enter using 24-hour format)
SX	Start EDP streaming	OK or ??
EX	Stop EDP streaming	OK or ??
DX	Start streaming raw A/D counts	OK or ??
RS	Reset system	—
XA	Transmit accumulator value	nnnnnn UU
XG	Transmit gross weight in displayed units	where nnnnnn is the weight value, UU is the units.
XN	Transmit net weight in displayed units	
XT	Transmit tare weight in displayed units	
XG2	Transmit gross weight in non-displayed units	
XN2	Transmit net weight in non-displayed units	
XT2	Transmit tare weight in non-displayed units	
XE	Query system error conditions	nnnnn nnnnn See Section 10.1 on page 60 for detailed information about the XE command response format.

Table 5-12. Normal Mode EDP Commands

5.2 Saving and Transferring Data

Connecting a personal computer to the IQ plus 710 EDP port allows you to save indicator configuration data to the PC or to download configuration data from the PC to an indicator. The following sections describe the procedures for these save and transfer operations.

5.2.1 Saving and Printing Indicator Data

Configuration data can be saved to a personal computer connected to the EDP port. The PC must be running a communications program such as PROCOMMPLUS® or CROSSTALK®. See Section 2.3.2 on page 6 for information about serial communications wiring and EDP port pin assignments.

When configuring the indicator, ensure that the values set for the BAUD and BITS parameters on the SERIAL menu match the baud rate, bits, and parity settings configured for the serial port on the PC.

To save all configuration data, send the DUMPALL EDP command to the indicator. The IQ plus 710 responds by sending all configuration parameters to the PC as ASCII-formatted text.

Configuration data can also be sent to the printer port: To print configuration data, place the indicator in setup mode, then press the ID key.

5.2.2 Downloading Configuration Data from PC to Indicator

Configuration data saved on a PC or floppy disk can be downloaded from the PC to an indicator. This procedure is useful when a number of indicators with similar configurations are set up or when an indicator is replaced.

To download configuration data, connect the PC to the EDP port as described in Section 5.2.1. Place the indicator in setup mode and use the PC communications software to send the saved configuration data to the indicator. When transfer is complete, calibrate the indicator as described in Section 4.0 on page 33.

NOTE: Calibration settings are included in the configuration data downloaded to the indicator. If the receiving indicator is a direct replacement for another IQ plus 710 and the attached scale is not changed, recalibration is not required.

6.0 Print Formatting

The IQ plus 710 provides six print formats that determine the format of the printed output when the PRINT key is pressed or when a KPRINT EDP command is received. Supported print formats are: GFMT, NFMT, EDPFMT, TRWIN, TRWOUT, and SPFMT. A fourth format, HDRFMT, allows specification of up to 300 characters of ticket header information for use on GFMT, NFMT, and EDPFMT tickets. The contents of the HDRFMT format can be inserted into any other ticket format using the <AE> formatting command.

The particular ticket format used for a given print operation depends on the indicator configuration (see Table 6-2 on page 44).

Each print format can be customized to include up to 300 characters of information, such as company name and address, on printed tickets. You can use the indicator front panel (PFORMT menu), EDP commands, or the Revolution™ Scaleware configuration utility to customize the print formats.

6.1 Print Formatting Commands

Table 6-1 lists commands you can use to format the IQ plus 710 print formats. Commands included in the format strings must be enclosed between < and > delimiters. Any characters outside of the delimiters are printed as text on the ticket. Text characters can include any ASCII character that can be printed by the output device.

Command	Description	Ticket Format		
		GFMT/NFMT/ EDPFMT	TRWIN/TRWOUT	SPFMT
<G>	Gross weight in displayed units	√		
<G2>	Gross weight in non-displayed units	√		
<N>	Net weight in displayed units	√		
<N2>	Net weight in non-displayed units	√		
<T>	Tare weight in displayed units	√		
<T2>	Tare weight in non-displayed units	√		
<A>	Accumulated weight in displayed units	√		
<AC>	Number of accumulator event (5-digit counter)	√		
<AT>	Time of last accumulator event	√		
<AD>	Date of last accumulator event	√		
<TR1>	Gross weight for current ticket in displayed units		√	
<TR2>	Tare weight for current ticket in displayed units		√	
<TR3>	Net weight for current ticket in displayed units		√	
<SV1>	Setpoint value when tripped in displayed units			√
<SV2>	Label for SV1 value			√
<BN>	Current setpoint number			√
<NA>	Current setpoint name			√
<TI>	Time	√	√	√
<DA>	Date	√	√	√
<TD>	Time and date	√	√	√
<ID>	ID number	√	√	√
<CN>	Consecutive number	√	√	√
<AE>	Ticket header (HDRFMT)	√	√	√

Table 6-1. Print Format Commands

Command	Description	Ticket Format		
		GFMT/NFMT/ EDPFMT	TRWIN/TRWOUT	SPFMT
<NLnn>	New line (nn = number of termination (<CR/LF> or <CR>) characters)*	√	√	√
<SPnn>	Space (nn = number of spaces)*	√	√	√
<SU>	Toggle weight data format (formatted/unformatted)**	√	√	√

NOTES:
Gross, net, and tare weights, SV1 setpoint weight are 9 digits in length, including sign (10 digits with decimal point), followed by a space and a two-digit units identifier. Total field length with units identifier is 12 (or 13) characters.
TR1, TR2, and TR3 truck ticket weight data includes keywords INBOUND, KEYED, RECALLED, as necessary.
ID and consecutive number (CN) fields are 1–7 characters in length, as required.
Ticket header (AE) inserts information specified for the HDRFMT header format.
* If nn is not specified, 1 is assumed. Value must be in the range 1–99.
** After receiving an SU command, the indicator sends unformatted data until the next SU command is received. Unformatted data omits decimal points, leading and trailing characters.

Table 6-1. Print Format Commands (Continued)

NOTE: The <G2>, <N2>, and <T2> commands listed in Table 6-1 print the gross, net, and tare weights in non-displayed units—that is, in the units *not* currently displayed on the indicator.

6.2 Default Ticket Formats

Table 6-2 shows the default print formats for the IQ plus 710 and lists the conditions under which each print format is used. The HDRFMT format is used to specify header information that can be used by the other ticket formats. The contents of the HDRFMT format can be inserted into any other ticket format using the <AE> formatting command.

Format	Default Format String	Used When
GFMT	GROSS<G><NL2><TD><NL>	Normal mode, no tare in system
NFMT	GROSS<G><NL>TARE<SP><T><NL>NET<SP2><N> <NL2><ID><NL>	Normal mode, tare in system
EDPFMT	GROSS<G><NL2><TD><NL>	Normal mode, PRNDEST=BOTH (SERIAL menu). GFMT (or NFMT) print format is sent to printer port simultaneously.
TRWIN	<NL>ID<SP><ID><NL2>GROSS<TR1> <NL2><DA><SP><TI><NL>	Truck mode (TARE100 ≠ OFF), when truck ID is entered
TRWOUT	<NL6>ID<SP><ID><NL2>GROSS<TR1><NL>TARE<SP><TR2> <NL>NET<SP2><TR3><NL2><DA><SP><TI><NL>	Truck mode (TARE100 ≠ OFF), when PRINT key pressed
SPFMT	<SV1><SP><SV2><NL>	Setpoint push print operation (PSHPRNT=ON)
HDRFMT	COMPANY NAME<NL>STREET ADDRESS<NL> CITY, ST ZIP<NL2>	N/A

Table 6-2. Default Print Formats

6.3 Customizing Print Formats

The following sections describe procedures for customizing print formats using the EDP port, the front panel (PFORMT menu), and the Revolution Scaleware configuration utility.

6.3.1 Using the EDP Port

With a personal computer, terminal, or remote keyboard attached to the IQ plus 710 EDP port, you can use the EDP command set to customize the print format strings.

To view the current setting of a format string, type the name of the print format and press ENTER. For example, to check the current configuration of the GFMT format, type GFMT and press ENTER. The indicator responds by sending the current configuration for the gross format:

```
GFMT=<G> GROSS<NL>
```

To change the format, use the GFMT or NFMT EDP command followed by an equals sign (=) and the modified print format string. For example, to add the name and address of a company to the gross format, you could send the following EDP command:

```
GFMT=MOE'S DUMP<NL>2356 EAST HIGHWAY  
ROAD<NL>SMALLTOWN<NL2><G> GROSS<NL>
```

A ticket printed using this format might look like the following:

```
MOE'S DUMP  
2356 EAST HIGHWAY ROAD  
SMALLTOWN
```

```
1345 LB GROSS
```

The ticket above could also be formatted by specifying the company address information in the HDRFMT ticket format, then substituting the <AE> command for the address in the GFMT ticket format:

```
HDRFMT=MOE'S DUMP<NL>2356 EAST HIGHWAY  
ROAD<NL>SMALLTOWN<NL2>
```

```
GFMT=<AE><G> GROSS<NL>
```

6.3.2 Using the Front Panel

If you have no access to equipment for communication through the EDP port or are working at a site where such equipment cannot be used, you can use the PFORMT menu (see Figure 6-2 on page 46) to customize the print formats.

Using the PFORMT menu, you can edit the print format strings by changing the decimal values of the ASCII characters in the format string.

NOTE: Lower-case letters and some special characters cannot be displayed on the IQ plus 710 front panel (see the ASCII character chart on page 63) and are shown as blanks. The IQ plus 710 can send or receive any ASCII character; the character printed depends on the particular ASCII character set implemented for the receiving device.

6.3.3 Using Revolution Scaleware

The Revolution Scaleware configuration utility provides a print formatting grid with a tool bar. The grid allows you to construct the print format without the formatting commands (<NL> and <SP>) required by the front panel or EDP command methods. Using Revolution, you can type text directly into the grid, then select weight value fields from the tool bar and place them where you want them to appear on the printed ticket.

Figure 6-1 shows an example of the Revolution Scaleware print formatting grid.

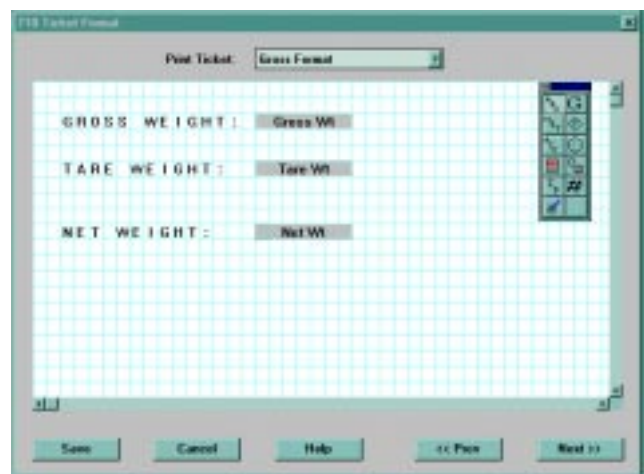

Figure 6-1. Revolution Scaleware Print Format Grid

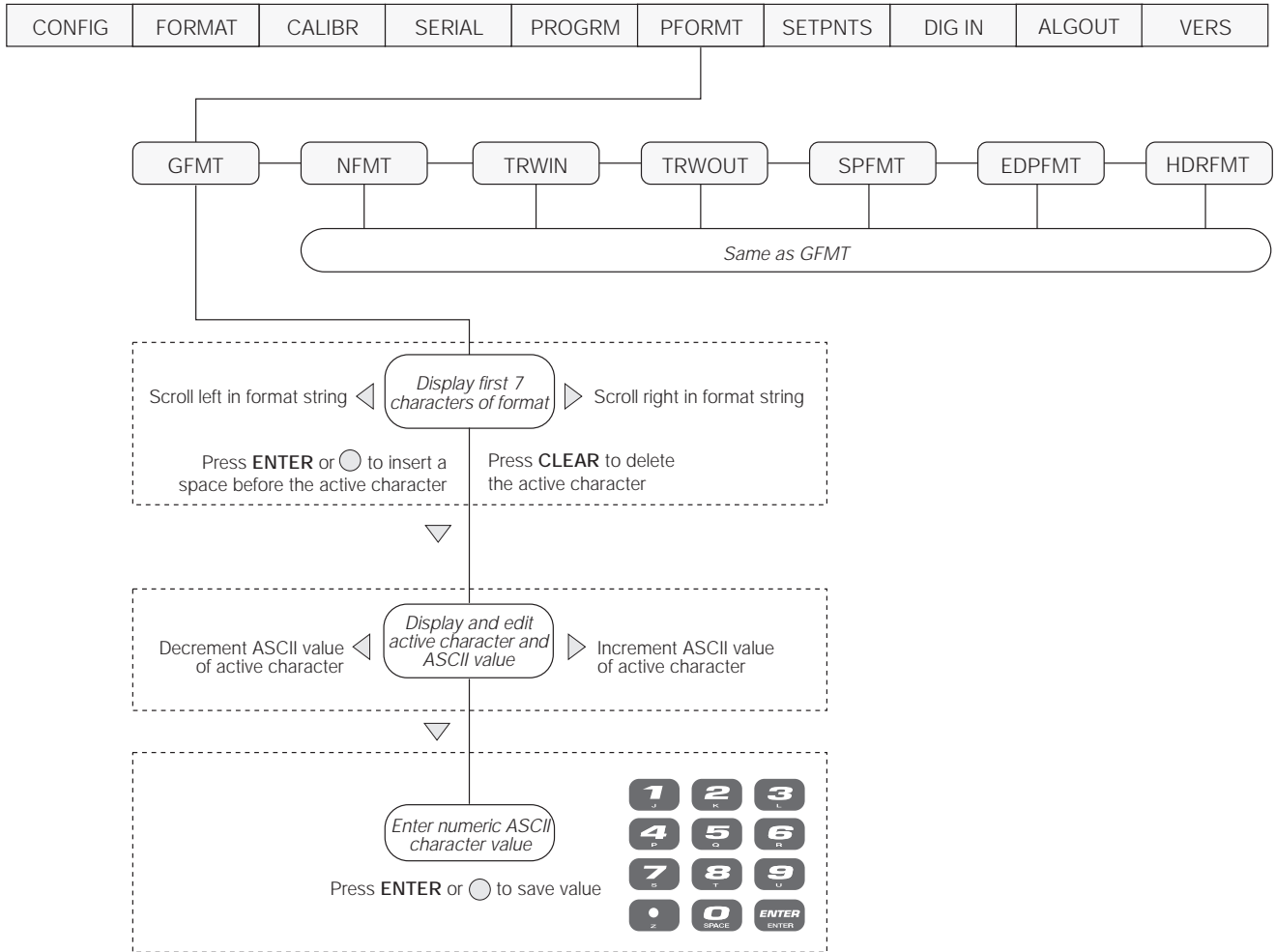

Figure 6-2. PFORMT Menu, Showing Alphanumeric Character Entry Procedure

7.0 Truck Modes

The truck in/out modes are used to handle multiple truck ID numbers and tare weights. Six truck modes combine stored ID, keyed tare, and value swapping features in various ways:

Mode	Stored IDs	Keyed Tares	Value Swapping
MODE1	NO	YES	YES
MODE2	NO	NO	YES
MODE3	YES	YES	YES
MODE4	YES	NO	YES
MODE5	YES	YES	NO
MODE6	YES	NO	NO
OFF			

Table 7-1. Truck Mode Features

Stored IDs let you keep a database of truck IDs and tare weights in the indicator's memory. The indicator can automatically store up to 100 truck IDs and tares; or it can clear the information after printing a weigh-out ticket. For example, if the same truck seldom crosses the scale, it may not be practical to save its ID number and tare weight. However, if that same truck crosses the scale many times each day, it's much more convenient to store the information in the indicator memory and recall it when needed. Stored IDs and tare weights are available in Modes 3, 4, 5, and 6.

Keyed tares allow you to manually enter the tare weight using the numeric keypad and the TARE key. Keyed tares are available in Modes 1, 3, and 5.

NOTE: Some local regulations require the tare weight to be read from the scale. If so, don't use the keyed tares feature.

Value swapping ensures that the lowest of two weight values associated with a particular ID number is entered as the tare weight. For example, if a truck crosses the scale fully loaded at weigh-in, then unloads and crosses the scale empty at weigh-out, the indicator automatically assigns the lesser (empty truck) weight as the tare. Value swapping is available in Modes 1, 2, 3, and 4.

To select a truck in/out mode, press the setup switch to enter setup mode. Use the navigation keys to go to the PROGRM menu, then to the TARE100 submenu. Figure 7-1 shows the structure of the TARE100 submenu.

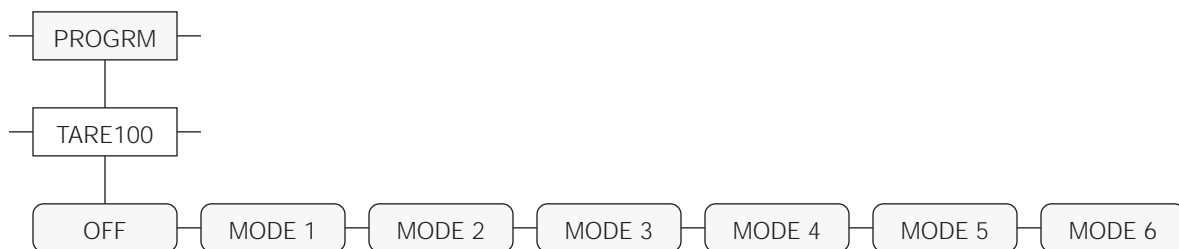

Figure 7-1. TARE100 Truck Mode Selections

7.1 Using the Truck Modes

All the truck in/out modes let you quickly search the memory for a specific ID number. To do this, key in the ID number and press the DISPLAY TARE key. If the number is in memory, it remains on the display. Otherwise, the indicator displays *NO ID*. Press ENTER to toggle between the ID number and tare weight. To delete the displayed ID number, press CLEAR twice.

To scroll through all the stored ID numbers, key in any number and press DISPLAY TARE. Each time you press DISPLAY TARE, the next number appears on the display.

To print all the stored ID numbers and their associated tare weights, press PRINT when an ID number is on the screen.

7.1.1 Modes 1 and 2

In modes 1 and 2, the indicator erases truck ID numbers and tare weights from memory after the transaction.

1. The truck moves onto the scale for weigh-in.
2. If keyed tares are enabled (Mode 1), key in the desired tare weight and press **TARE**.
3. Key in an ID number (up to 7 digits) and press **ID**. This information remains in memory until the weigh-out ticket is printed.
4. The indicator prints the weigh-in ticket (TRWIN format) shown below:
ID. NO. 304812
GROSS 15000. LB INBOUND
08/04/1998 10:24 AM
5. The loaded truck moves onto the scale for weigh-out.
6. Key in the ID number from the weigh-in ticket and press **PRINT**. The indicator prints a weigh-out ticket (TRWOUT format) and automatically clears the information from memory: If the tare weight is a keyed tare, the word *KEYED* is printed after *RECALLED* on the tare line.

7.1.2 Modes 3, 4, 5, and 6

In modes 3–6, the indicator stores the tare weights and ID numbers in memory until you manually erase them.

1. The truck moves onto the scale for weigh-in.
2. If keyed tares are enabled (Modes 3, 5), key in the desired tare weight, then press **TARE**.
3. Key in an ID number (up to 7 digits) and press **I.D.** This information remains in memory until manually deleted.
4. The indicator prints the weigh-in ticket (TRWIN format). Truck leaves.
5. The loaded truck moves back onto the scale for weigh-out.
6. Key in the ID number and press **PRINT**. The indicator prints the weigh-out ticket (TRWOUT format). If value swapping is enabled (modes 3 and 4), the lower weight is always printed as the tare weight.
ID. NO. 304812
GROSS 100000. LB
TARE 15000. LB RECALLED
NET 85000. LB
08/04/1998 10:55 AM

8.0 Setpoints

The IQ plus 710 indicator provides eight programmable setpoints for control of both indicator and external equipment functions. Setpoints are configured to trip based on specified conditions; tripping the setpoint can be used to request indicator functions (print, tare, accumulate) or to change the state of a digital output controlling external equipment.

Figure 8-1 shows the general structure of the SETPNTS menu. See Section 3.2.7 on page 27 for a detailed description of the SETPNTS menu. The eight setpoint kinds are described in Table 8-1 on page 50.

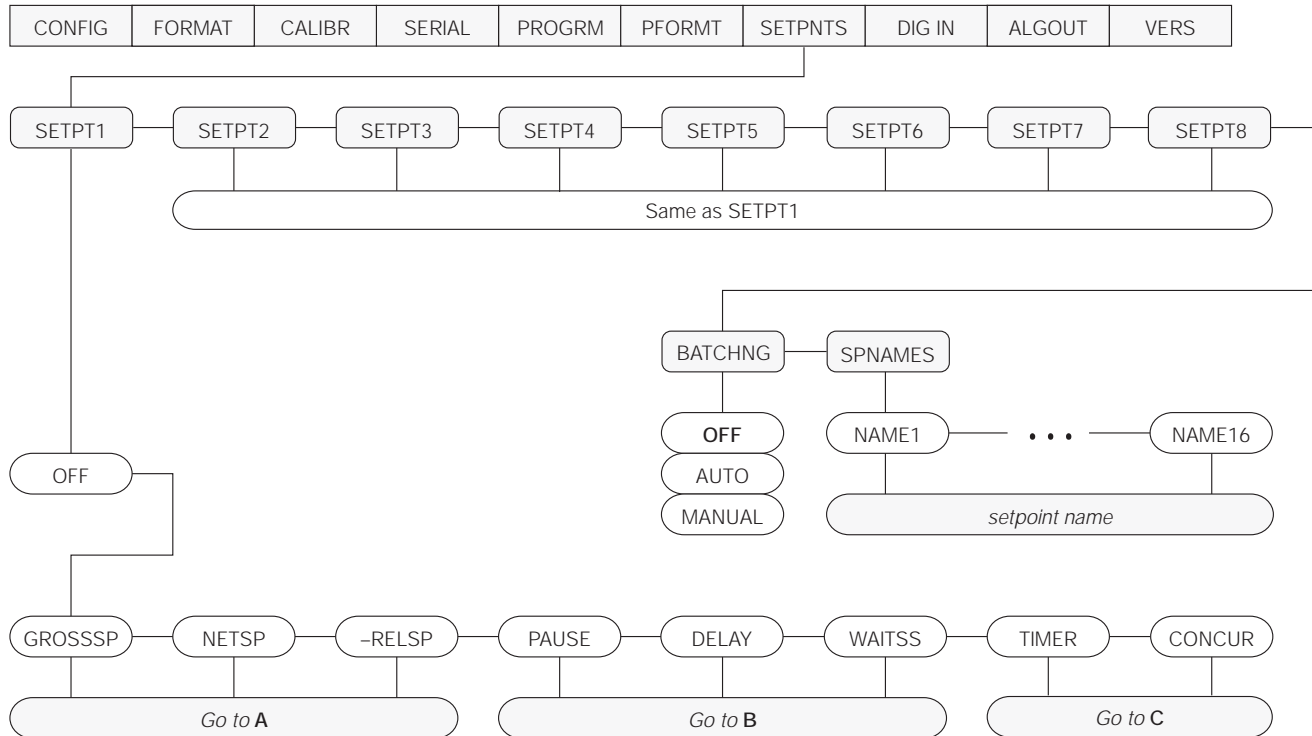

Figure 8-1. SETPNTS Menu

8.1 Batch and Continuous Setpoints

IQ plus 710 setpoints can be either continuous or batch setpoints.

Continuous setpoints are free-running: the indicator constantly checks the input channel for the setpoint value at each A/D update. If the input channel weight reading matches the setpoint value, the indicator sets the corresponding digital output on.

Batch setpoints are active one at a time, in an ordered sequence. The IQ plus 710 can use batch setpoints to control up to eight separate batch processing steps. A digital output associated with a batch setpoint is on until the setpoint condition is met, then latched for the remainder of the batch sequence.

To use batch setpoints, you must activate the BATCHNG parameter on the SETPNTS menu. This parameter defines whether a batch sequence is automatic or manual. AUTO sequences repeat continuously, while MANUAL sequences require a BATSTRT digital input or STRTBAT macro command before restarting. As shown in Table 8-1 on page 50, GROSSSP, NETSP, and -RELSP setpoint kinds can be configured as either batch or continuous setpoints.

The BATCH parameter must also be set on for each batch setpoint. If the setpoint is defined but the BATCH parameter is off, the setpoint operates as a continuous setpoint, even during batch sequences.

Kind	Description	Batch	Continuous
OFF	Setpoint turned off/ignored.		
GROSSSP	Gross setpoint. Trips when the current gross weight matches this value.	√	√
NETSP	Net setpoint. Trips when the current net weight matches this value.	√	√
-RELSP	Negative relative setpoint. Trips at a specific value below the referenced setpoint.	√	√
PAUSE	Pauses the batch sequence indefinitely. Operator must activate the BATSTRT digital input to continue processing.	√	
DELAY	Delays the batch sequence for a specified time. The length of the delay (in tenths of a second) is specified on the Value parameter.	√	
WAITSS	Wait for standstill. Pauses the batch sequence until the scale is at standstill.	√	
TIMER	Tracks the progress of a batch sequence based on a timer. The timer value, specified in tenths of a second on the VALUE parameter, determines the length of time allowed between start and end setpoints. The indicator START and END parameters are used to specify the start and end setpoints. If the END setpoint is not reached before the timer expires, the digital output associated with this setpoint is activated.		√
CONCUR	Allows a digital output to remain active over a specified portion of the batch sequence. Two types of concur setpoints can be configured: Type 1: The digital output associated with this setpoint becomes active when the START setpoint becomes the current batch step and remains active until the END setpoint becomes the current batch step. Type 2: The digital output associated with this setpoint becomes active when the START setpoint becomes the current batch step and remains active until a timer expires. The indicator START and END parameters specify the start and end setpoints. The timer value is specified in tenths of a second on the VALUE parameter.		√

Table 8-1. Setpoint Kinds

8.2 Batching Examples

8.2.1 Example 1

The following example uses seven setpoints to dispense material from a container in 100 LB batches and to automatically refill the container when its weight drops below 300 LB.

Digital inputs 1 and 2 are assigned to batch start and batch run functions: BATRUN must be on (low) before the BATSTRT input starts the batch.

```
DIGIN1=BATSTRT
DIGIN2=BATRUN
BATCHNG=MANUAL
```

Setpoint 1 ensures that the container has enough material to start the batch. If the container weight is 300 LB or higher, setpoint 1 is tripped.

```
SETPOINT=1
KIND=GROSSSP
VALUE=300
TRIP=HIGHER
BATCH=ON
ACCESS=HIDE
```

Setpoint 2 waits for standstill, then performs a tare to put the indicator into net mode.

```
SETPOINT=2
KIND=WAITSS
PSHTARE=ON
ACCESS=HIDE
```

Setpoint 3 is used as a reference (relative setpoint) for setpoint 4 and is tripped with a weight of 0 ± 2 LB.

```
SETPOINT=3
KIND=NETSP
VALUE=0
TRIP=INBAND
BANDVAL=2
BATCH=ON
ACCESS=HIDE
```

Setpoint 4 is used to dispense material from the container. When the container weight falls to 100 LB less than its weight at the relative setpoint (setpoint 3), digital output 1 is set off.

```
SETPOINT=4
KIND=-RELS
VALUE=100
TRIP=LOW
BATCH=ON
ACCESS=ON
DIGOUT=1
RELNUM=3
```

Setpoint 5 is a short (.2-second) delay used to provide an end point for a timer setpoint (setpoint 6).

```
SETPOINT=5
KIND=DELAY
VALUE=2
ACCESS=HIDE
```

Setpoint 6 is used to ensure that the fill operation performed in setpoints 3 and 4 is completed within 10 seconds. The START and END parameters identify the setpoints monitored by the timer. If the timer expires before setpoint 5 starts, digital output 4 is turned on as an alarm to signal a process fault.

```
SETPOINT=6
KIND=TIMER
VALUE=100
START=3
END=5
ACCESS=HIDE
DIGOUT=4
```

Setpoint 7 is a continuous setpoint, used to maintain the material level in the container. When the container weight falls below 300 LB (VALUE – HYSTERESIS), digital output 2 is turned on and the container refilled to 1000 LB.

```
SETPOINT=7
KIND=GROSSSP
VALUE=1000
TRIP=LOW
HYSTER=700
BATCH=OFF
ACCESS=HIDE
DIGOUT=2
```

Most of the setpoints in the preceding example use ACCESS=HIDE to prevent changes to the configured setpoint values. Setpoint 4 uses ACCESS=ON to allow changes to the fill weight.

8.2.2 Example 2

The following example uses seven setpoints to control a two-speed fill operation where both fast and slow feeds are on simultaneously.

Digital inputs 1 and 2 are assigned to batch start and batch run functions: BATRUN must be on (low) before the BATSTRT input starts the batch.

```
DIGIN1=BATSTRT
DIGIN2=BATRUN
BATCHNG=MANUAL
```

Setpoint 1 ensures that the scale is empty (0 ± 2 LB).

```
SETPOINT=1
KIND=GROSSSP
VALUE=0
TRIP=INBAND
VALUE=2
BATCH=ON
```

Setpoint 2 checks for the weight of a container (≥ 5 LB) placed on the scale.

```
SETPOINT=2
KIND=GROSSSP
VALUE=5
TRIP=HIGHER
BATCH=ON
```

Setpoint 3 waits for standstill, then tares the container weight, placing the indicator in net mode.

```
SETPOINT=3
KIND=WAITSS
PSHTARE=ON
```

Setpoint 4 starts the fast fill operation. When the net weight reaches 175 LB, the setpoint trips and digital output 1 is set off.

```
SETPOINT=4
KIND=NETSP
VALUE=175
TRIP=HIGHER
BATCH=ON
DIGOUT=1
```

Setpoint 5 controls the slow fill operation. When the net weight reaches 200 LB, the slow fill is stopped (see Setpoint 7), the indicator waits for standstill and performs a push print operation using the SPFMT ticket format.

```
SETPOINT=5
KIND=NETSP
VALUE=200
PSHPRINT=WAITSS
TRIP=HIGHER
BATCH=ON
```

Setpoint 6 is a short (.2-second) delay used to provide an end point for a concur setpoint (setpoint 7).

```
SETPOINT=6
KIND=DELAY
VALUE=2
```

Setpoint 7 is a continuous setpoint, used to allow the slow feed output to be on at the same time as the fast fill. The slow fill output (digital output 2) is turned on when setpoint 4 (fast fill) starts and remains on until setpoint 5 (slow fill) reaches 200 LB.

```
SETPOINT=7
KIND=CONCUR
VALUE=0
START=4
END=6
DIGOUT=2
```

9.0 Macro Programming

Up to four macro sequences can be programmed for the IQ plus 710 indicator. Each macro provides a simulation of up to 30 front panel key presses and can be used to provide single-key, automated operation of a number of processes, including operator identification, prompts, setpoint editing, and batch control.

9.1 Using the Macro Submenu

Macros can be programmed using the front panel, EDP commands, or Revolution Scaleware. Figure 9-1 shows the structure of the MACRO submenu under the PROGRAM menu; Table 9-1 on page 54 describes each of the MACRO submenu parameters.

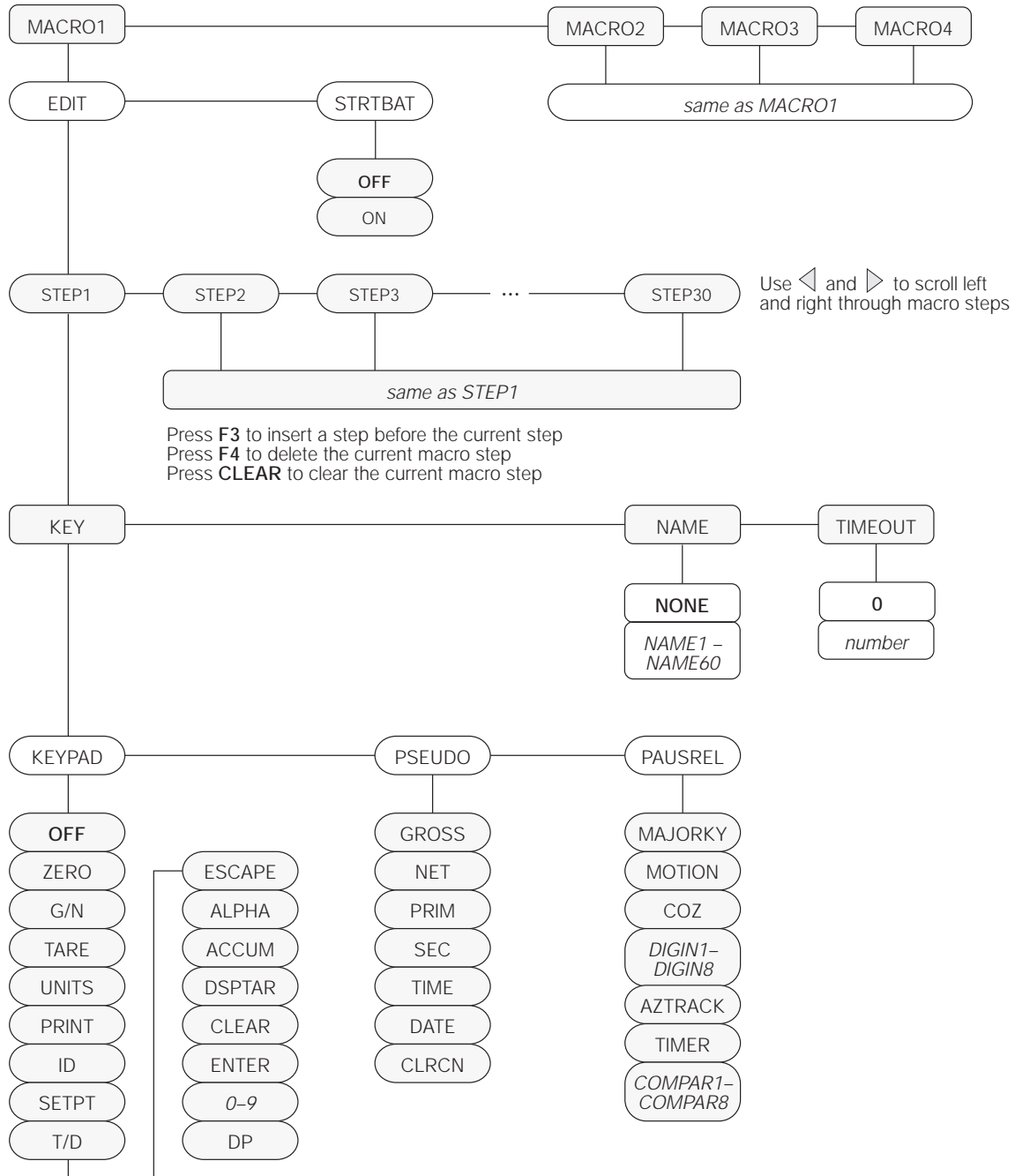

Figure 9-1. Macro Submenu under PROGRAM Menu

PROGRM Menu		
Parameter	Choices	Description
<i>Level 2 MACRO submenu</i>		
MACRO1 MACRO2 MACRO3 MACRO4	EDIT STRTBAT	Configure macros
<i>Level 3 MACRO submenu</i>		
EDIT	<i>macro sequence</i>	Create or display a macro sequence
STRTBAT	OFF ON	Specifies whether a batch sequence is automatically started when the macro sequence ends. STRTBAT=ON is functionally equivalent to the BATSTRT digital input.
<i>Level 4 MACRO submenu</i>		
STEP1 – STEP30	KEY NAME TIMEOUT	Select macro step
<i>Level 5 MACRO submenu</i>		
KEY	KEYPAD PSEUDO PAUSREL	Specifies whether the keystroke simulated by the macro is an actual keypad key, a pseudo key, or a pause release.
NAME	NONE NAME1 – NAME60	Specifies the text, if any, shown on the secondary display during macro execution. NAME1 through NAME60 are specified on the PROMPTS parameter.
TIMEOUT	<i>number</i>	If TIMER is specified for the PAUSREL parameter, specify a timer value in the range 0–65535, in 0.1-second intervals. For example, specify TIMER=150 to insert a 15-second pause.
<i>Level 6 MACRO submenu</i>		
KEYPAD	OFF ZERO G/N TARE UNITS PRINT ID SETPT T/D ESCAPE ALPHA ACCUM DSPTAR CLEAR ENTER 0–9 DP	Select front panel key simulated by this macro step.
PSEUDO	GROSS NET PRIM SEC TIME DATE CLRCN	The PSEUDO parameter allows simulation of a pseudo key for the macro step. Pseudo keys are keypad functions not represented by an actual front panel key. For example, the PRIM pseudo key displays the primary units configured for the indicator, but there is no actual primary units key on the front panel. The PRIM and SEC pseudo keys are used to explicitly request primary or secondary units display; the UNITS front panel key toggles between primary and secondary units, depending on which is displayed at the time the key is pressed.

Table 9-1. MACRO Submenu Parameters (PROGRM Menu)

PROGRM Menu		
Parameter	Choices	Description
PAUSREL	MAJORKY MOTION COZ DIGIN1 – DIGIN8 AZTRACK TIMER COMPAR1 – COMPAR8	The PAUSEREL parameter inserts a pause in the macro sequence that is released when the specified condition is met. The value specified for this parameter determines when the pause is released: MAJORKY: When any of the five major keys is pressed MOTION: When scale reaches standstill COZ: When scale reaches center of zero DIGIN1–DIGIN8: When DIGINx goes active AZTRACK: When scale is within zero track band TIMER: When timer expires (timer value is specified on TIMEOUT parameter) COMPAR1 – COMPAR8: When a continuous setpoint x (1–8) changes state

Table 9-1. MACRO Submenu Parameters (PROGRM Menu)

9.2 Macro Programming Examples



Warning

To prevent injury and equipment damage, always test macros and batching routines thoroughly before connecting the indicator to a live system.

9.2.1 Example 1

The following example uses a macro to provide operator prompts for a simple container filling procedure. The single setpoint is used to check for a full container; when tripped, the setpoint releases the pause in step 3 of the macro.

With the indicator in setup mode, the following EDP commands are sent to program the setpoint and assign prompts used by the macro.

```
SETPOINT=1
KIND=NETSP
VALUE=200
TRIP=HIGHER
BATCH=OFF
DIGOUT=NONE
BATCHNG=OFF
```

```
PROMPT#1=ADD BOX
PROMPT#2=ADD MATERIAL
PROMPT#3=REMOVE BOX
```

NOTE: Prompts are assigned using the PROMPT#*n* EDP command or the PROMPTS parameter on the PROGRM menu. Prompts are recalled for display during macro execution using the NAME.*n* EDP parameter or the NAME parameter under the macro submenu.

The macro shown below is started when the operator presses the F1 macro key:

MACRO 1

```
MACRO1.K01=PAUSREL.MOTION
MACRO1.K01=NAME.1
MACRO1.K02=KTARE
MACRO1.K03=PAUSREL.COMPAR1
MACRO1.K03=NAME.2
MACRO1.K04=KPRINT
MACRO1.K05=PAUSREL.COZ
MACRO1.K05=NAME.3
```

1. The first macro step displays the prompt *ADD BOX* on the secondary display and waits for scale motion caused by the operator placing the box on the scale. When scale motion stops, the pause is released and the macro continues.
2. The macro performs a tare operation, taring the box weight and placing the indicator in net mode.
3. The secondary display prompts the operator to *ADD MATERIAL*. The prompt is held on the display until setpoint 1 changes state (COMPAR1). When the setpoint trips, the pause is released.
4. The macro performs a print operation using the NFMT ticket format.
5. The secondary display prompts the operator to *REMOVE BOX*. The prompt is held on the display until the gross weight on the scale goes to zero.

9.2.2 Example 2

The following example uses a combination of macros and batch routines to control a filling operation. The operation includes filling a container with two ingredients, pausing the batch for a mixing operation, then adding a third ingredient.

With the indicator in setup mode, the following EDP commands are sent to program the setpoints and assign prompts used by the macros.

```
SETPOINT=1  
KIND=NETSP  
VALUE=5  
TRIP=HIGHER  
BATCH=ON  
DIGOUT=1
```

```
SETPOINT=2  
KIND=NETSP  
VALUE=10  
TRIP=HIGHER  
BATCH=ON  
DIGOUT=2
```

```
SETPOINT=3  
KIND=PAUSE  
DIGOUT=3
```

```
SETPOINT=4  
KIND=NETSP  
VALUE=15  
TRIP=HIGHER  
BATCH=ON  
DIGOUT=4
```

```
SETPOINT=5  
KIND=WAITSS  
PSHPRINT=ON  
DIGOUT=NONE  
SETPOINT=6  
KIND=PAUSE  
DIGOUT=5
```

```
SETPOINT=7  
KIND=GROSSSP  
VALUE=0  
TRIP=HIGHER  
BATCH=ON  
DIGOUT=6
```

```
BATCHNG=MANUAL
```

```
PROMPT#1=ADD BUCKET  
PROMPT#2=MIX PAINT  
PROMPT#3=REMOVE BUCKET
```

Digital input 1 is connected to a batching switch and configured as a BATRUN input. The batching switch must be on to enable the STRTBAT (batch start) commands in the macros.

Digital inputs 2–4 are wired from digital outputs 3, 5, and 6: When the setpoints associated with the digital outputs are tripped, the output activates the digital input to start the next macro.

```
DIGIN1=BATRUN  
DIGIN2=KF2  
DIGIN3=KF3  
DIGIN4=KF1
```

The macros shown below begin when the operator presses the F1 macro key:

1. MACRO 1 displays the prompt *ADD BUCKET* on the secondary display and waits for scale motion caused by the operator placing the bucket on the scale. When scale motion stops, the pause is released and the macro continues.

MACRO 1

```
MACRO1.STRTBAT=ON  
MACRO1.K01=PAUSREL.MOTION  
MACRO1.K01=NAME.1  
MACRO1.K02=KTARE
```

2. The macro performs a tare operation, taring the bucket weight and placing the indicator in net mode.
3. The STRTBAT=ON macro statement starts the batch once the tare operation is complete.
4. The batch starts, adding Ingredient A until the bucket net weight reaches 5 LB (see SETPOINT 1 configuration above). When setpoint 1 trips, DIGOUT 1 goes off and Ingredient A stops filling.
5. Setpoint 2 adds Ingredient B until the bucket net weight reaches 10 LB (see SETPOINT 2 configuration above). When setpoint 2 trips, DIGOUT 2 goes off and Ingredient B stops filling.
6. Setpoint 3 is a pause setpoint used to activate digital output 3. Digital output 3 is wired to DIGIN2 as a KF2 (press MACRO key F2) input and starts MACRO 2.

MACRO 2

MACRO2.STRTBAT=ON
MACRO2.K01=PAUSREL.MOTION
MACRO2.K01=NAME.2

7. MACRO 2 displays the prompt *MIX PAINT* on the secondary display and waits for scale motion caused by the operator mixing the paint. When scale motion stops, the pause is released and the macro restarts the batch sequence at Setpoint 4.
8. Setpoint 4 adds Ingredient C until the bucket net weight reaches 15 LB (see SETPOINT 4 configuration). When setpoint 1 trips, DIGOUT 4 goes off and Ingredient C stops filling.
9. Setpoint 5 waits for standstill then prints ticket using the SPFMT ticket format.
10. Setpoint 6 is a pause setpoint used to activate digital output 5. Digital output 5 is wired to DIGIN3 as a KF3 (press MACRO key F3 input and starts MACRO 3.

MACRO 3

MACRO3.STRTBAT=ON
MACRO3.K01=PAUSREL.COZ
MACRO3.K01=NAME.3
MACRO3.K02=KZERO

11. MACRO 3 displays the prompt *REMOVE BUCKET* on the secondary display and waits until the gross weight on the scale goes to zero. When the scale reaches center of zero, the pause is released and the macro zeroes the scale (KZERO command) and restarts the batch at Setpoint 7.
12. Setpoint 7 checks that the gross weight on the scale is zero, then activates digital output 6. Digital output 6 is wired to DIGIN4 as a KF1 (press MACRO key F1) input and starts MACRO 1 again.

9.2.3 Example 3

The following example describes how a series of macros can be programmed to provide single-key reprogramming of setpoint values. Table 9-2 shows the values of three setpoints used to fill different proportions of ingredients for three products.

Setpoint Values	PRODUCT A	PRODUCT B	PRODUCT C
INGRED 1	100	150	110
INGRED 2	200	250	210
INGRED 3	300	280	290

Table 9-2. Setpoint Values for Three-Ingredient Products

With the indicator in setup mode, the following EDP commands are sent to program three gross setpoints to their initial values and assign setpoint names used by the macros.

```
SETPOINT=1
KIND=GROSSSP
VALUE=100
TRIP=HIGHER
BATCH=ON
ACCESS=ON
NAME=1
DIGOUT=1
```

```
SETPOINT=2
KIND=GROSSSP
VALUE=200
TRIP=HIGHER
BATCH=ON
ACCESS=ON
NAME=2
DIGOUT=2
```

```
SETPOINT=3
KIND=GROSSSP
VALUE=300
TRIP=HIGHER
BATCH=ON
ACCESS=ON
NAME=3
DIGOUT=3
```

```
BATCHNG=MANUAL
```

```
PROMPT#1=INGRED 1
PROMPT#2=INGRED 2
PROMPT#3=INGRED 3
PROMPT#4=LOAD PRODUCT A
PROMPT#5=LOAD PRODUCT B
PROMPT#6=LOAD PRODUCT C
```

Next, three macros are programmed to allow reassignment of the setpoint values for each of the three products.

Each macro uses the SETPOINT key to change the setpoint value: the SETPOINT key is pressed once to call up setpoint 1; press SETPOINT again to call up setpoint 2. Each time the SETPOINT key is pressed, the value of the *next* setpoint is shown.

The three macros listed below reset the setpoint values for PRODUCT A, PRODUCT B, and PRODUCT C. MACRO1 sets the values of setpoints 1–3 to the initial values listed above.

NOTES:

- When the front panel SETPOINT key is pressed, the indicator normally waits before showing the setpoint value. To accommodate this delay, a timer is inserted before each setpoint value entry.
- Pause release parameters (PAUSREL, NAME, TIMEOUT) are entered on separate EDP commands, but are treated as a single keystroke.

MACRO 1

```
MACRO1.K01=PAUSREL.TIMER
MACRO1.K01=NAME.4
MACRO1.K01=TIMEOUT.100
```

```
MACRO1.K02=KSETPOINT
MACRO1.K03=PAUSREL.TIMER
MACRO1.K03=NAME.1
MACRO1.K03=TIMEOUT.35
MACRO1.K04=K1
MACRO1.K05=K0
MACRO1.K06=K0
MACRO1.K07=KENTER
```

```
MACRO1.K08=KSETPOINT
MACRO1.K09=PAUSREL.TIMER
MACRO1.K09=NAME.2
MACRO1.K09=TIMEOUT.35
MACRO1.K10=K2
MACRO1.K11=K0
MACRO1.K12=K0
MACRO1.K13=KENTER
```

```
MACRO1.K14=KSETPOINT
MACRO1.K15=PAUSREL.TIMER
MACRO1.K15=NAME.3
MACRO1.K15=TIMEOUT.35
MACRO1.K16=K3
MACRO1.K17=K0
MACRO1.K18=K0
MACRO1.K19=KENTER
```

MACRO 2

MACRO2.K01=PAUSREL.TIMER
MACRO2.K01=NAME.5
MACRO2.K01=TIMEOUT.100

MACRO2.K02=KSETPOINT
MACRO2.K03=PAUSREL.TIMER
MACRO2.K03=NAME.1
MACRO2.K03=TIMEOUT.35
MACRO2.K04=K1
MACRO2.K05=K5
MACRO2.K06=K0
MACRO2.K07=KENTER

MACRO2.K08=KSETPOINT
MACRO2.K09=PAUSREL.TIMER
MACRO2.K09=NAME.2
MACRO2.K09=TIMEOUT.35
MACRO2.K10=K2
MACRO2.K11=K5
MACRO2.K12=K0
MACRO2.K13=KENTER

MACRO2.K14=KSETPOINT
MACRO2.K15=PAUSREL.TIMER
MACRO2.K15=NAME.3
MACRO2.K15=TIMEOUT.35
MACRO2.K16=K2
MACRO2.K17=K8
MACRO2.K18=K0
MACRO2.K19=KENTER

MACRO 3

MACRO3.K01=PAUSREL.TIMER
MACRO3.K01=NAME.6
MACRO3.K01=TIMEOUT.100

MACRO3.K02=KSETPOINT
MACRO3.K03=PAUSREL.TIMER
MACRO3.K03=NAME.1
MACRO3.K03=TIMEOUT.35
MACRO3.K04=K1
MACRO3.K05=K1
MACRO3.K06=K0
MACRO3.K07=KENTER

MACRO3.K08=KSETPOINT
MACRO3.K09=PAUSREL.TIMER
MACRO3.K09=NAME.2
MACRO3.K09=TIMEOUT.35
MACRO3.K10=K2
MACRO3.K11=K1
MACRO3.K12=K0
MACRO3.K13=KENTER

MACRO3.K14=KSETPOINT
MACRO3.K15=PAUSREL.TIMER
MACRO3.K15=NAME.3
MACRO3.K15=TIMEOUT.35
MACRO3.K16=K2
MACRO3.K17=K9
MACRO3.K18=K0
MACRO3.K19=KENTER

10.0 Appendix

10.1 Error Messages

The IQ plus 710 indicator provides a number of error messages. When an error occurs, the message is shown on the indicator display. Error conditions can also be checked remotely by using the XE EDP command as described in Section 10.1.2.

10.1.1 Displayed Error Messages

The IQ plus 710 provides a number of front panel error messages to assist in problem diagnosis. Table 10-1 lists these messages and their meanings.

Error Message	Description	Solution
E A/D	A/D physical error	Call Rice Lake Weighing Systems (RLWS) Service.
E EEROM	EEPROM physical error	
E VIREE	Virgin EEPROM	Use TEST menu to perform DEFLT (restore defaults) procedure, then recalibrate scale.
E PCKSM	Parameter checksum error	
EFCKSM	Printer format checksum error	
E LCKSM	Load cell calibration checksum error	Recalibrate scale.
E ACKSM	A/D calibration checksum error	A/D converter requires recalibration. Call RLWS Service.
E IDATA	Internal RAM test error	Call RLWS Service.
E XDATA	External RAM test error	
E REF	A/D reference error	A/D converter requires recalibration. Call RLWS Service.
OVERFL	Overflow error	Weight value too large to be displayed.
REG ERR	Battery fault	Battery weak or not installed. Replace battery then use TEST menu to perform CLR NV (clear non-volatile storage) procedure.
ACC ERR	Accumulator overflow error	Press ACCUM to display accumulator value, then press CLEAR twice to clear the accumulator.
-----	Gross > overload limit	Gross value exceeds overload limit. Check configuration.
_____	A/D underrange	A/D reading < -4 mV. Check scale for binding or damage.

Table 10-1. IQ plus 710 Error Messages

10.1.2 Using the XE EDP Command

The XE EDP command can be used to remotely query the IQ plus 710 for the error conditions shown on the front panel. The XE command returns two 5-digit numbers in the format:

xxxxx yyyyy

where xxxxx contains a decimal representation of any existing error conditions as described in Table 10-2.

If more than one error condition exists, the number returned is the sum of the values representing the error conditions. For example, if the XE command returns the number 288, this value represents the sum of an A/D reference error (256) and an A/D calibration checksum error (32).

The second number returned (yyyyy) uses the same bit assignments as shown in Table 10-2 on page 61 to indicate whether the test for the error condition was run. For example, the value yyyyy = 50687 represents the decimal equivalent of the binary value 1100 0101 1111 1111. Using the bit assignments in Table 10-2, this indicates all tests were run except the accumulator overflow and NV register checksum tests.

Error Code	Description	Binary Value
0	No error	0000 0000 0000 0000
1	A/D physical error	0000 0000 0000 0001
2	EEPROM physical error	0000 0000 0000 0010
4	Virgin EEPROM	0000 0000 0000 0100
8	Parameter checksum error	0000 0000 0000 1000
16	Load cell calibration checksum error	0000 0000 0001 0000
32	A/D calibration checksum error	0000 0000 0010 0000
64	Internal RAM data error	0000 0000 0100 0000
128	External RAM data error	0000 0000 1000 0000
256	A/D reference error	0000 0001 0000 0000
512	NV register checksum error	0000 0010 0000 0000
1024	Printer format checksum error	0000 0100 0000 0000
2048	<i>not assigned</i>	0000 1000 0000 0000
4096	Accumulator overflow error	0001 0000 0000 0000
8192	<i>not assigned</i>	0010 0000 0000 0000
16384	A/D underrange	0100 0000 0000 0000
32768	Gross > overload limit	1000 0000 0000 0000

Table 10-2. Error Codes Returned on XE Command

10.2 Status Messages

Two EDP commands, P and ZZ, can be used to provide status about the indicator.

- The P EDP command returns whatever is currently shown in the indicator's primary display area.
- The ZZ EDP command returns whatever is currently shown in both the primary and secondary displays. Depending on the type of device used to receive data from the indicator, the standstill and center of zero symbols may be shown as spaces or as special characters. The ZZ command returns information in the following format:

PPPPPPP uu sssssssssssssss

where:

- *PPPPPPP* is the information shown on the primary display
- *uu* is the 2-digit units annunciator
- *ssssssssssssss* is the contents of the secondary display

If the indicator is in an underrange or overload condition, the weight value is replaced with &&&&& (overload) or : : : : (underrange).

10.3 Data Formats

10.3.1 Continuous Output Serial Data Format

If continuous transmission is configured for the EDP or printer port (STREAM parameter on the SERIAL menu), the IQ plus 710 sends data using the Consolidated Controls serial data format shown in Figure 10-1:

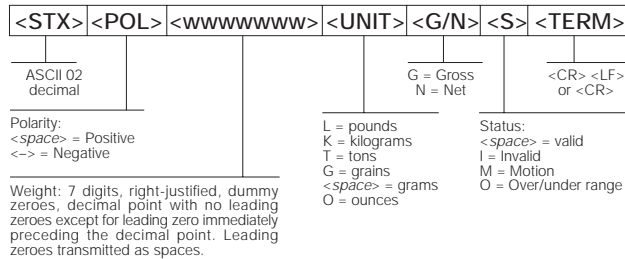

Figure 10-1. Continuous Output Serial Data Format

10.3.2 Demand Output Serial Data Format

When demand mode is configured for the EDP or printer port in the setup menus (PRNDEST on the SERIAL menu), the IQ plus 710 uses a data string formatted for a basic ticket printout. The particular ticket format printed depends on the indicator configuration.

You can use the EDP port or keypad to fully customize the ticket to work with a wide variety of printers, scoreboard displays, and other remote equipment. See Section 6.0 on page 43 for more information on custom print formats.

10.3.3 RS-485 Data Formats

The IQ plus 710 has a built-in RS-485 software protocol which is enabled when you assign a non-zero address to the indicator. Valid RS-485 addresses must be in the range 1–255; the address is specified on the ADDRESS parameter on the SERIAL menu.

All remote commands are initiated using the data format shown in Figure 10-2:

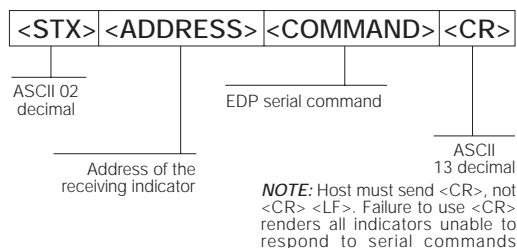

Figure 10-2. RS-485 Send Data Format

If the initiating device address matches the port address of an IQ plus 710 on the RS-485 network, that indicator responds. For example, with demand outputs, or in response to a KPRINT command, the responding indicator uses the format shown in Figure 10-3:

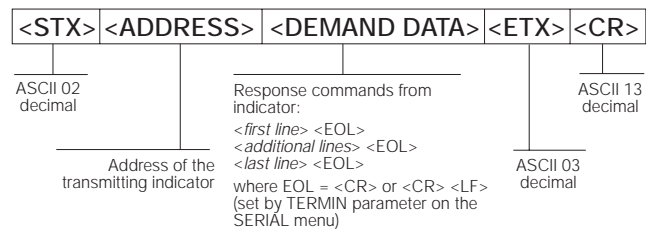

Figure 10-3. RS-485 Respond Data Format

Example: To send the KPRINT command from an ASCII terminal to an indicator at address 65 (decimal) on the RS-485 network, use the format shown in Figure 10-2.

- The keyboard equivalent for the start-of-text (STX) character is CONTROL-B (see Table 10-3 on page 63).
- The indicator address (65) is represented by an upper case “A”.
- The carriage return (CR) character is generated by pressing the ENTER key.

Therefore, to send the KPRINT command to the indicator at address 65, enter the following at the terminal: CONTROL-B, A, K, P, R, I, N, T, ENTER.

The indicator responds with the format shown in Figure 10-3:

```
<STX> A SCALE #1 <EOL>
      GROSS 1699 LB<EOL>
      08/20/1998 10:05 AM<EOL>
<ETX> <CR>
```

If continuous transmission is configured for the EDP port (STREAM parameter on the SERIAL menu), the IQ plus 710 sends data using the data format shown in Figure 10-4:

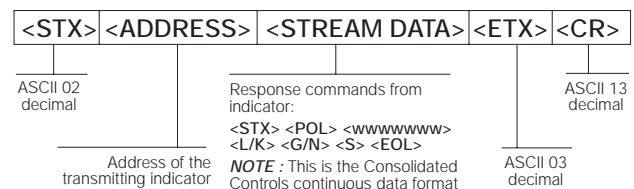

Figure 10-4. RS-485 Continuous Data Format

10.4 ASCII Character Chart

Use the decimal values for ASCII characters listed in Tables 10-3 and 10-4 when specifying print format strings on the IQ plus 710 PFORMT menu. The actual character printed depends on the character mapping used by the output device.

The IQ plus 710 can send or receive any ASCII character value (decimal 0–255). Due to limitations of the indicator display, some characters cannot be shown.

Control	ASCII	Dec	Hex	ASCII	Dec	Hex	ASCII	Dec	Hex	ASCII	Dec	Hex
Ctrl-@	NUL	00	00	space	32	20	@	64	40	`	96	60
Ctrl-A	SOH	01	01	!	33	21	A	65	41	a	97	61
Ctrl-B	STX	02	02	“	34	22	B	66	42	b	98	62
Ctrl-C	ETX	03	03	#	35	23	C	67	43	c	99	63
Ctrl-D	EOT	04	04	\$	36	24	D	68	44	d	100	64
Ctrl-E	ENQ	05	05	%	37	25	E	69	45	e	101	65
Ctrl-F	ACK	06	06	&	38	26	F	70	46	f	102	66
Ctrl-G	BEL	07	07	’	39	27	G	71	47	g	103	67
Ctrl-H	BS	08	08	(40	28	H	72	48	h	104	68
Ctrl-I	HT	09	09)	41	29	I	73	49	i	105	69
Ctrl-J	LF	10	0A	*	42	2A	J	74	4A	j	106	6A
Ctrl-K	VT	11	0B	+	43	2B	K	75	4B	k	107	6B
Ctrl-L	FF	12	0C	,	44	2C	L	76	4C	l	108	6C
Ctrl-M	CR	13	0D	-	45	2D	M	77	4D	m	109	6D
Ctrl-N	SO	14	0E	.	46	2E	N	78	4E	n	110	6E
Ctrl-O	SI	15	0F	/	47	2F	O	79	4F	o	111	6F
Ctrl-P	DLE	16	10	0	48	30	P	80	50	p	112	70
Ctrl-Q	DC1	17	11	1	49	31	Q	81	51	q	113	71
Ctrl-R	DC2	18	12	2	50	32	R	82	52	r	114	72
Ctrl-S	DC3	19	13	3	51	33	S	83	53	s	115	73
Ctrl-T	DC4	20	14	4	52	34	T	84	54	t	116	74
Ctrl-U	NAK	21	15	5	53	35	U	85	55	u	117	75
Ctrl-V	SYN	22	16	6	54	36	V	86	56	v	118	76
Ctrl-W	ETB	23	17	7	55	37	W	87	57	w	119	77
Ctrl-X	CAN	24	18	8	56	38	X	88	58	x	120	78
Ctrl-Y	EM	25	19	9	57	39	Y	89	59	y	121	79
Ctrl-Z	SUB	26	1A	:	58	3A	Z	90	5A	z	122	7A
Ctrl-[ESC	27	1B	;	59	3B	[91	5B	{	123	7B
Ctrl-\	FS	28	1C	<	60	3C	\	92	5C		124	7C
Ctrl-]	GS	29	1D	=	61	3D]	93	5D	}	125	7D
Ctrl-^	RS	30	1E	>	62	3E	^	94	5E	~	126	7E
Ctrl- <u>_</u>	US	31	1F	?	63	3F	_	95	5F	DEL	127	7F

Table 10-3. ASCII Character Chart (Part 1)

ASCII	Dec	Hex	ASCII	Dec	Hex	ASCII	Dec	Hex	ASCII	Dec	Hex
Ç	128	80	á	160	A0		192	C0	α	224	E0
ü	129	81	í	161	A1		193	C1	β	225	E1
é	130	82	ó	162	A2		194	C2	Γ	226	E2
â	131	83	ú	163	A3		195	C3	π	227	E3
ä	132	84	ñ	164	A4		196	C4	Σ	228	E4
à	133	85	Ñ	165	A5		197	C5	σ	229	E5
å	134	86	ª	166	A6		198	C6	μ	230	E6
ç	135	87	º	167	A7		199	C7	τ	231	E7
ê	136	88	¿	168	A8		200	C8	Φ	232	E8
ë	137	89		169	A9		201	C9	Θ	233	E9
è	138	8A	¬	170	AA		202	CA	Ω	234	EA
ï	139	8B	½	171	AB		203	CB	δ	235	EB
î	140	8C	¼	172	AC		204	CC	∞	236	EC
ì	141	8D	¡	173	AD		205	CD	φ	237	ED
Ä	142	8E	«	174	AE		206	CE	ε	238	EE
Å	143	8F	»	175	AF		207	CF	∩	239	EF
É	144	90		176	B0		208	D0	≡	240	F0
æ	145	91		177	B1		209	D1	±	241	F1
Æ	146	92		178	B2		210	D2	≥	242	F2
ô	147	93		179	B3		211	D3	≤	243	F3
ö	148	94		180	B4		212	D4	∫	244	F4
ò	149	95		181	B5		213	D5	∫	245	F5
û	150	96		182	B6		214	D6	÷	246	F6
ù	151	97		183	B7		215	D7	≈	247	F7
ÿ	152	98		184	B8		216	D8	°	248	F8
Ö	153	99		185	B9		217	D9	•	249	F9
Ü	154	9A		186	BA		218	DA		250	FA
ç	155	9B		187	BB		219	DB		251	FB
£	156	9C		188	BC		220	DC		252	FC
¥	157	9D		189	BD		221	DD	²	253	FD
Pts	158	9E		190	BE		222	DE		254	FE
f	159	9F		191	BF		223	DF		255	FF

Table 10-4. ASCII Character Chart (Part 2)

10.5 Digital Filtering

Standard digital filtering uses mathematical averaging to eliminate the variant digital readings that the A/D converter sends periodically because of external vibration. Digital filtering does not affect the indicator measurement rate, but does affect the settling time. The selections from 1 to 256 reflect the number of readings averaged per update period. When a reading is encountered that is outside a predetermined band, the averaging is overridden, and the display jumps directly to the new value.

RATTLETRAP® digital filtering (DIGFLTR values followed by the letters RT) uses a vibration-dampening algorithm to provide a combination of the best features of analog and digital filtering. The RATTLETRAP algorithm evaluates the frequency of a repeating vibration then derives a composite displayed weight equal to the actual weight on the scale less the vibration-induced flaws. It is particularly effective for eliminating vibration effects or mechanical interference from nearby machinery. RT selections eliminate much more mechanical vibration than standard digital filtering, but usually also increase settling time over standard digital filtering.

10.5.1 DFSENS and DFTHR parameters

The digital filter can be used by itself to eliminate vibration effects, but heavy filtering also increases settling time. The DFSENS (digital filter sensitivity) and DFTHR (digital filter threshold) parameters can be used to temporarily override filter averaging and improve settling time:

- DFSENS specifies the number of consecutive scale readings that must fall outside the filter threshold (DFTHR) before digital filtering is suspended.
- DFTHR sets a threshold value, in display divisions. When a specified number of consecutive scale readings (DFSENS) fall outside of this threshold, digital filtering is suspended.

10.6 Conversion Factors for Secondary Units

The IQ plus 710 has the capability to mathematically convert a weight into many different types of units and instantly display those results with a press of the UNITS key.

Secondary units can be specified on the FORMAT menu using the SECNDR parameter, or by using EDP commands.

- To configure secondary units using the front panel menus, use the Table 10-5 to find the conversion multiplier for the MULT

10.5.2 Setting the Digital Filter Parameters

Fine-tuning the digital filter parameters greatly improves indicator performance in heavy-vibration environments. Use the following procedure to determine vibration effects on the scale and optimize the digital filtering configuration.

1. In setup mode, set the digital filter (DIGFLTR parameter) to 1. Set DFTHR to NONE. Return indicator to normal mode.
2. Remove all weight from the scale, then watch the indicator display to determine the magnitude of vibration effects on the scale. Record the weight below which all but a few readings fall. This value is used to calculate the DFTHR parameter value in Step 4.

For example, if a heavy-capacity scale produces vibration-related readings of up to 50 lb, with occasional spikes to 75 lb, record 50 lb as the threshold weight value.

3. Place the indicator in setup mode and set the DIGFLTR parameter to eliminate the vibration effects on the scale. (Leave DFTHR set to NONE.) Find the lowest effective value for the DIGFLTR parameter.
4. Calculate the DFTHR parameter value by converting the weight value recorded in Step 2 to display divisions:

$$\text{threshold_weight_value} / \text{DSPDIV}$$

In the example in Step 2, with a threshold weight value of 50 lb and a display division value of 5D: $50 / 5D = 10$. DFTHR should be set to 10DD for this example.

5. Finally, set the DFSENS parameter high enough to ignore transient peaks. Longer transients (typically caused by lower vibration frequencies) will cause more consecutive out-of-band readings, so DFSENS should be set higher to counter low frequency transients.

Reconfigure as necessary to find the lowest effective value for the DFSENS parameter.

parameter. For example, if the primary unit is pounds and the secondary unit is short tons, set the MULT parameter to 0.000500.

- To configure secondary units using EDP commands, use the Table 10-5 to find the conversion multiplier for the SEC.MULT command. For example, if the primary unit is pounds and the secondary unit is short tons, send the EDP command SEC.MULT=0.0005<CR> to set the multiplier for the secondary units.

NOTE: Ensure that the secondary decimal point position is set appropriately for the scale capacity in the secondary units. If the converted value requires more digits than are available, the indicator will display an overflow message (*OVERFL*).

For example, if the primary units are short tons, secondary units are pounds, and the secondary decimal point is set to 8888.888, the indicator will overflow if 5 tons or more are applied to the scale. With 5 tons applied, and a conversion factor of 2000, the secondary units display needs five digits to the left of the decimal point to display the 10000 lb secondary units value.

Primary Unit	<i>x Multiplier</i>	Secondary Unit
grains	0.064799	grams
	0.002286	ounces
	0.000143	pounds
	0.000065	kilograms
	0.002083	troy ounces
	0.000174	troy pounds
ounces	437.500	grains
	28.3495	grams
	0.06250	pounds
	0.02835	kilograms
	0.911458	troy ounces
	0.075955	troy pounds
pounds	7000.00	grains
	453.592	grams
	16.0000	ounces
	0.453592	kilograms
	14.58333	troy ounces
	1.215278	troy pounds
	0.000500	short tons
	0.000446	long tons
	0.000453	metric tons
grams	15.4324	grains
	0.035274	ounces
	0.002205	pounds
	0.001000	kilograms
	0.032151	troy ounces
	0.002679	troy pounds

Table 10-5. Conversion Factors

Primary Unit	<i>x Multiplier</i>	Secondary Unit
kilograms	15432.4	grains
	35.2740	ounces
	1000.00	grams
	2.20462	pounds
	32.15075	troy ounces
	2.679229	troy pounds
	0.001102	short tons
	0.000984	long tons
	0.001000	metric tons
short tons	2000.00	pounds
	907.185	kilograms
	0.892857	long tons
	0.907185	metric tons
metric tons	2204.62	pounds
	1000.00	kilograms
	1.10231	short tons
	0.984207	long tons
long tons	2240.00	pounds
	1016.05	kilograms
	1.12000	short tons
	1.01605	metric tons
troy ounces	480	grains
	31.10348	grams
	0.031103	kilograms
	1.09714	ounces
	0.068571	pounds
	0.083333	troy pounds
troy pounds	5760	grains
	373.2417	grams
	0.373242	kilograms
	13.16571	ounces
	0.822857	pounds
	12	troy ounces

Table 10-5. Conversion Factors (Continued)

10.7 Analog Output Calibration

The following calibration procedure requires a multimeter to measure voltage or current output from the analog output module. If the option is not already installed, see Section 2.4 on page 6.

NOTE: The analog output must be calibrated *after* the indicator itself has been configured (Section 3.0) and calibrated (Section 4.0).

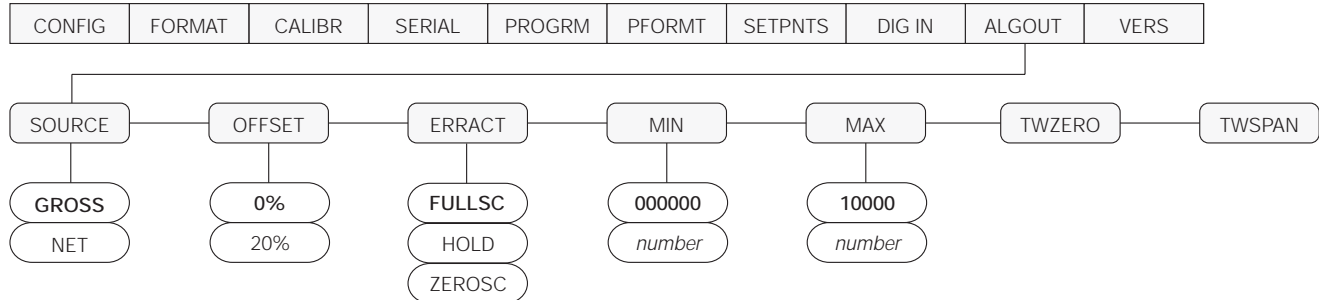

Figure 10-5. Analog Output Menu

- Enter setup mode and go to the ALGOUT menu (see Figure 10-5):
 - Set OFFSET to 0% for 0–10 V output, 20% for 4–20 mA output
 - Set MIN to lowest weight value to be tracked by the analog output
 - Set MAX to highest weight value to be tracked by the analog output
- Connect multimeter to connector J1 on the analog output board:
 - For voltage output, connect voltmeter leads to pins 3 and 4
 - For current output, connect ammeter leads to pins 1 and 2
- Adjust zero calibration: Scroll to the TWZERO parameter. Check voltage or current reading on multimeter. Press and hold Δ or ∇ to adjust the zero value up or down.
- Adjust span calibration: Scroll to the TWSPAN parameter. Check voltage or current reading on multimeter. Press and hold Δ or ∇ to adjust the span value up or down.
- Final zero calibration: Return to the TWZERO parameter and verify that the zero calibration has not drifted. Press and hold Δ or ∇ to re-adjust the zero value as required.
- Return to normal mode. Analog output function can be verified using test weights.

10.8 Test Mode

In addition to normal and setup modes, test mode provides a number of diagnostic functions for the IQ plus 710, including:

- Display raw A/D count
- Set digital outputs on and display digital input states
- Reset configuration parameters to default values
- Clear non-volatile (battery backed) storage
- Clear EEPROM
- Transmit test character (“U”) from serial port
- Display characters received by serial port
- Set analog output state to zero or full scale
- Set A/D offset and gain calibration

To enter test mode, press and hold the setup switch until the front panel display shows the word *TEST*. In test mode, the front panel keys are mapped to the test mode functions as shown in Figure 10-6 and Table 10-6 on page 68.



Caution

A/D calibration functions, ADOFFS and ADGAIN, must be used only by qualified service personnel, and only after replacing A/D converter components. Improper A/D calibration may render the indicator unusable.

The CLEAR EEPROM function erases both A/D and load cell calibration data. The A/D converter and the scale must be recalibrated after using this function.

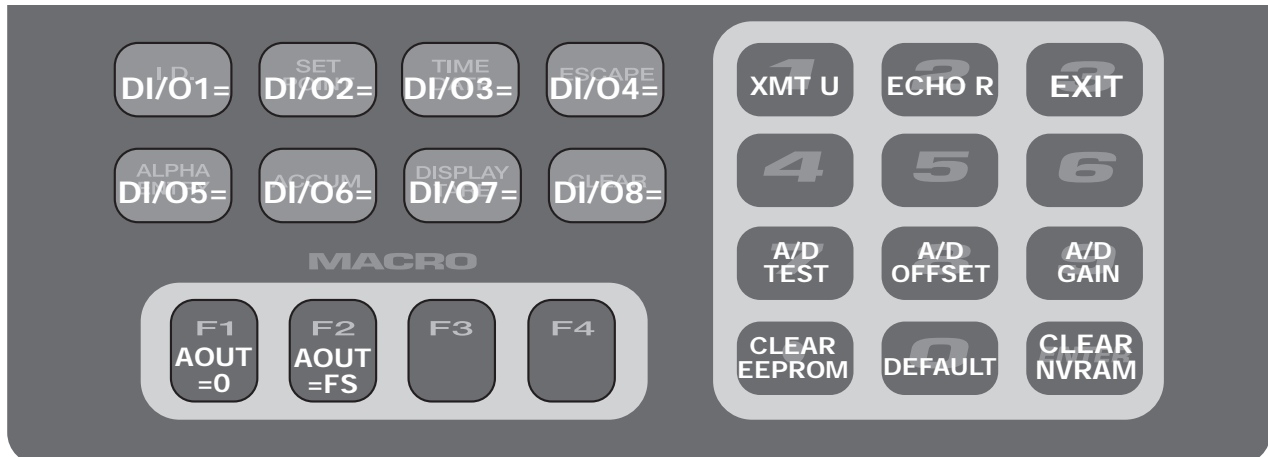

Figure 10-6. Front Panel Key Functions in Test Mode

TEST Menu	
Function	Description
DI/O1 —DI/O8	Set digital output x high and display status of digital input x Press and hold DI/Ox= key (see Figure 10-6) to show status of DIGINx (Dlx=HI or Dlx=LO).
AOUT=0	Set analog output to zero Press and hold the F1 key to set analog output to its zero value.
AOUT=FS	Set analog output to full scale Press and hold the F2 key to set analog output to its full scale value.
XMT U	Transmit "U" Press and hold the 1 key to send ASCII "U" characters (decimal 85) from the serial port.
ECHO R	Echo received characters Press and hold the 2 key to view characters received at serial port. NOTE: IQ plus 710 display shows lower-case characters as blanks.
A/D TEST	Display A/D test Press and hold the 7 key to display raw count from A/D converter.
CLEAR NVRAM	Clear non-volatile storage Press and hold the setup switch, then press the ENTER key to clear values stored in battery-backed SRAM, including truck mode data, time, and date.
DEFAULT	Default parameters Press and hold the setup switch, then press the 0 key to reset configuration and calibration parameters to factory default values. Load cells must be recalibrated before using the indicator (see Section 4.0 on page 33).
CLEAR EEPROM	Clear EEPROM Read Caution! statement on page 67 before using this function. Press and hold the setup switch, then press the . (decimal_point) key to clear EEPROM.
A/D OFFSET	A/D offset calibration (–0.5 mv/V) Read Caution! statement on page 67 before using this function. Press and hold the setup switch, then press the 8 key to perform offset calibration.
A/D GAIN	A/D gain calibration (+4.5 mv/V) Read Caution! statement on page 67 before using this function. Press and hold the setup switch, then press the 9 key to perform gain calibration.
EXIT	Press the 3 key to exit test mode.

Table 10-6. Test Menu Functions

10.9 Software Upgrade Instructions

Use the following procedure to replace the IQ plus 710 EPROM:

1. Disconnect indicator from power source.
2. Place indicator face-down on an antistatic work mat. Remove screws that hold the backplate to the enclosure body.

 **Warning** *Disconnect power before removing indicator backplate.*

3. Loosen all in-use cord grips then lift the backplate away from the enclosure and set it aside.

 **Caution** *Use a wrist strap to ground yourself and protect components from electrostatic discharge (ESD) when working inside the indicator enclosure.*

4. For units using the Rev. 1 CPU board with cable interface board, remove the four screws that secure the interface board to its mounting brackets. The interface board must be moved to access the EPROM in the following step.
5. Locate the EPROM (see Figure 2-1 on page 5). Carefully remove old EPROM from socket.
6. Remove new EPROM from packaging and place on top of empty socket. Ensure EPROM is correctly oriented (notch toward center of CPU board) and all pins are aligned with socket. Press down firmly to seat new EPROM in the socket.

7. For units using the Rev. 1 CPU board with cable interface board, reinstall board using screws removed in Step 4.
8. Position backplate over the enclosure and reinstall the backplate screws. Use the torque pattern shown in Figure 2-2 on page 7 to prevent distorting the backplate gasket. Torque backplate screws to 10 in-lb (1.13 N-m).
9. Ensure no excess cable is left inside the enclosure and tighten cord grips.
10. Reconnect power to the indicator.
11. Remove the setup switch access screw on the indicator backplate then set the indicator upright.
12. Press and hold the setup switch until the front panel display shows the word *TEST*. Two test mode procedures must be performed before using the new EPROM:
 - Clear non-volatile RAM (CLR NV)
 - Restore defaults (DEFLT)
13. Press the ENTER key and the setup switch at the same time to clear non-volatile RAM. (See Figure 10-6 on page 68 for test mode keypad functions.)
14. Press the 0 (zero) key and the setup switch at the same time to restore defaults. The indicator automatically returns to normal mode when done.
15. Recalibrate and reconfigure the indicator.

10.10 Software Revision History

The following list summarizes the principal software changes made for Version 1.4:

Enhanced Display Resolution

Up to 100 000 grads can be specified on the GRADS parameter (CONFIG menu) and on the GRADS EDP command.

HDRFMT Ticket Header Print Format Added

Contents of the HDRFMT format can be inserted into any other ticket format using the <AE> formatting command. See Section 6.0 on page 43 for details.

Improved Digital Filtering

Digital filter sensitivity (DFSSENS) and threshold (DFTHR) parameters on the CONFIG menu provide improved digital filtering capability for the IQ plus 710. These values can also be configured using the DFSSENS and DFTHR EDP commands. See Section 10.5 on page 65 for detailed information about using these parameters.

10.11 Specifications

Power

Line Voltages	115 or 230 VAC
Frequency	50 or 60 Hz
Power Consumption	100 mA @ 115 VAC (11.5 W) 50 mA @ 230 VAC (11.5 W)

Fusing

115 VAC	2 x 160 mA TR5 subminiature fuses Wickmann Time-Lag 19374 Series UL Listed, CSA Certified and Approved
230 VAC	2 x 80 mA TR5 subminiature fuses Wickmann Time-Lag 19372 Series UL Recognized, Semko and VDE Approved

Analog Specifications

Full Scale Input Signal	Up to 45 mV
Excitation Voltage	10 ± 0.5 VDC, 8 x 350 Ω or 16 x 700 Ω load cells
Sense Amplifier	Differential amplifier with 4- and 6-wire sensing
Analog Signal Input Range	0.6 mV/V – 4.5 mV/V
Analog Signal Sensitivity	0.3 μ V/graduation minimum, 1.5 μ V/grad recommended
Input Impedance	200 M Ω , typical
Noise (ref to input)	0.3 μ V p-p with digital filter at 4
Internal Resolution	1 000 000 counts, approximate
Display Resolution	100 000 dd
Measurement Rate	60 measurements/sec, nominal
Input Sensitivity	50 nV per internal count
System Linearity	Within 0.01% of full scale
Zero Stability	150 nV/ $^{\circ}$ C, maximum
Span Stability	3.5 ppm/ $^{\circ}$ C, maximum
Calibration Method	Software, constants stored in EEPROM
Common Mode Voltage	± 4 V, referred to earth
Common Mode Rejection	140 dB minimum @ 50 or 60 Hz
Normal Mode Rejection	90 dB minimum @ 50 or 60 Hz
Input Overload	± 12 V continuous, static discharge protected
RFI Protection	Signal, excitation, and sense lines protected by capacitor bypass
Analog Output	Optional: fully isolated 0–10 VDC or 4–20 mA, 14-bit resolution

Digital Specifications

Microcomputer	Hitachi H8/3002 main processor @ 9.8304 MHz
Digital Inputs	8 inputs, TTL or switch closure, active-low
Digital Outputs	8 inputs, open collector with TTL pullup
Digital Filter	Software selectable: 1–256, enhanced Rattletrap [®] hybrid digital filtering

Serial Communications

EDP Port	Full duplex RS-232 or RS-485
Printer Port	RS-232 or active 20 mA current loop
Both Ports	19 200, 9600, 4800, 2400, 1200, 600, 300 bps; 7 or 8 data bits; even, odd, or no parity; two stop bits on transmit, one stop bit on receive

Operator Interface

Display	Vacuum fluorescent display: 7-digit, 14-segment primary weight display; Two 5x7 dot matrix digits for units, alpha/ numeric entry mode designators; 16-digit dot matrix display for additional symbols, user prompts.
Keyboard	29-key membrane panel

Environmental

Operating Temperature	–10 to +40 $^{\circ}$ C (legal); –10 to +50 $^{\circ}$ C (industrial)
Storage Temperature	–25 to +70 $^{\circ}$ C
Humidity	0–95% relative humidity
Altitude	2000 m (6500 ft) maximum

Enclosure

Enclosure Dimensions (without tilt stand)	
Sloped Enclosure:	9.5 in x 8.38 in x 4.95 in 241 mm x 213 mm x 126 mm
Flat Enclosure:	9.5 in x 8.38 in x 5.25 in 241 mm x 213 mm x 133 mm
Weight	
Sloped Enclosure:	7.4 lb (3.3 Kg)
Flat Enclosure:	7.8 lb (3.5 Kg)
Rating/Material	NEMA 4X/IP66, stainless steel

Certifications and Approvals



NTEP

CoC Number	98-081
Accuracy Class	III/III L n_{max} : 10 000



Measurement Canada

Approval	AM-5253
Accuracy Class	III n_{max} : 10 000 III HD n_{max} : 20 000

IQ plus 710 Limited Warranty

Rice Lake Weighing Systems (RLWS) warrants that all RLWS equipment and systems properly installed by a Distributor or Original Equipment Manufacturer (OEM) will operate per written specifications as confirmed by the Distributor/OEM and accepted by RLWS. All systems and components are warranted against defects in materials and workmanship for two years.

RLWS warrants that the equipment sold hereunder will conform to the current written specifications authorized by RLWS. RLWS warrants the equipment against faulty workmanship and defective materials. If any equipment fails to conform to these warranties, RLWS will, at its option, repair or replace such goods returned within the warranty period subject to the following conditions:

- Upon discovery by Buyer of such nonconformity, RLWS will be given prompt written notice with a detailed explanation of the alleged deficiencies.
- Individual electronic components returned to RLWS for warranty purposes must be packaged to prevent electrostatic discharge (ESD) damage in shipment. Packaging requirements are listed in a publication, *Protecting Your Components From Static Damage in Shipment*, available from RLWS Equipment Return Department.
- Examination of such equipment by RLWS confirms that the nonconformity actually exists, and was not caused by accident, misuse, neglect, alteration, improper installation, improper repair or improper testing; RLWS shall be the sole judge of all alleged non-conformities.
- Such equipment has not been modified, altered, or changed by any person other than RLWS or its duly authorized repair agents.
- RLWS will have a reasonable time to repair or replace the defective equipment. Buyer is responsible for shipping charges both ways.
- In no event will RLWS be responsible for travel time or on-location repairs, including assembly or disassembly of equipment, nor will RLWS be liable for the cost of any repairs made by others.

THESE WARRANTIES EXCLUDE ALL OTHER WARRANTIES, EXPRESSED OR IMPLIED, INCLUDING WITHOUT LIMITATION WARRANTIES OF MERCHANTABILITY OR FITNESS FOR A PARTICULAR PURPOSE. NEITHER RLWS NOR DISTRIBUTOR WILL, IN ANY EVENT, BE LIABLE FOR INCIDENTAL OR CONSEQUENTIAL DAMAGES.

RLWS AND BUYER AGREE THAT RLWS'S SOLE AND EXCLUSIVE LIABILITY HEREUNDER IS LIMITED TO REPAIR OR REPLACEMENT OF SUCH GOODS. IN ACCEPTING THIS WARRANTY, THE BUYER WAIVES ANY AND ALL OTHER CLAIMS TO WARRANTY.

SHOULD THE SELLER BE OTHER THAN RLWS, THE BUYER AGREES TO LOOK ONLY TO THE SELLER FOR WARRANTY CLAIMS.

NO TERMS, CONDITIONS, UNDERSTANDING, OR AGREEMENTS PURPORTING TO MODIFY THE TERMS OF THIS WARRANTY SHALL HAVE ANY LEGAL EFFECT UNLESS MADE IN WRITING AND SIGNED BY A CORPORATE OFFICER OF RLWS AND THE BUYER.

© 1999 Rice Lake Weighing Systems, Inc. Rice Lake, WI USA. All Rights Reserved.

RICE LAKE WEIGHING SYSTEMS • 230 WEST COLEMAN STREET • RICE LAKE, WISCONSIN 54868 • USA

EXCEPT AS STATED HEREIN, HOWE SCALE MAKES NO WARRANTY, EXPRESSED OR IMPLIED, WITH RESPECT TO THE PRODUCTS OR SERVICES SUPPLIED PURSUANT TO THESE TERMS AND CONDITIONS OF SALE. HOWE SCALE MAKES NO WARRANTY OF MERCHANTABILITY, FITNESS FOR ANY PARTICULAR PURPOSE, OR CONFORMANCE TO PURCHASER'S SPECIFICATIONS.

© 1999 Howe Scale, Inc. Fairfield, CT USA. All Rights Reserved.