

IQ plus[®] 510

Digital Weight Indicator

Version 1.4

Installation Manual



RICE LAKE WEIGHING SYSTEMS
Industrial Solutions on a Global Scale[®]



Contents

About This Manual	1
1.0 Introduction.....	1
1.1 Operating Modes	1
1.2 Front Panel Keypad	1
1.3 Indicator Operations	2
1.3.1 Toggle Gross/Net Mode	2
1.3.2 Toggle Units	2
1.3.3 Zero Scale	2
1.3.4 Acquire Tare	2
1.3.5 Remove Stored Tare Value	2
1.3.6 Print Ticket	2
2.0 Installation.....	3
2.1 Unpacking and Assembly	3
2.2 Enclosure Disassembly	3
2.3 Cable Connections	3
2.3.1 Load Cells	4
2.3.2 Serial Communications	5
2.3.3 Digital Inputs	5
2.3.4 Analog Output	5
2.4 Analog Output Module Installation	5
2.5 Enclosure Reassembly	6
2.6 Board Removal	6
2.7 Battery Replacement	6
2.8 Replacement Parts	7
3.0 Configuration.....	13
3.1 Configuration Methods	13
3.1.1 Revolution™ Scaleware Configuration	13
3.1.2 EDP Command Configuration	13
3.1.3 Front Panel Configuration	14
3.2 Menu Structures and Parameter Descriptions	15
3.2.1 Configuration Menu	16
3.2.2 Format Menu	18
3.2.3 Calibration Menu	21
3.2.4 Serial Menu	22
3.2.5 Program Menu	24
3.2.6 Print Format Menu	25
3.2.7 Digital Input Menu	26
3.2.8 Analog Output Menu	27
3.2.9 Version Menu	27
4.0 Calibration.....	28
4.1 Front Panel Calibration	28
4.2 EDP Command Calibration	29
4.3 Revolution™ Scaleware Calibration	30
5.0 EDP Commands.....	31
5.1 The EDP Command Set	31
5.1.1 Key Press Commands	31
5.1.2 Reporting Commands	32
5.1.3 The RESETCONFIGURATION Command	32
5.1.4 Parameter Setting Commands	32
5.1.5 Normal Mode Commands	35

5.2	Saving and Transferring Data	36
5.2.1	Saving Indicator Data to a Personal Computer	36
5.2.2	Downloading Configuration Data from PC to Indicator	36
6.0	Print Formatting	37
6.1	Print Formatting Commands	37
6.2	Customizing Print Formats.	38
6.2.1	Using the EDP Port.	38
6.2.2	Using the Front Panel	38
6.2.3	Using Revolution™ Scaleware.	39
7.0	Appendix	40
7.1	Error Messages	40
7.1.1	Displayed Error Messages	40
7.1.2	Using the XE EDP Command	40
7.2	Status Messages	41
7.3	Data Formats.	42
7.3.1	Continuous Output Serial Data Format	42
7.3.2	Demand Output Serial Data Format	42
7.3.3	RS-485 Data Formats.	42
7.4	ASCII Character Chart	43
7.5	Digital Filtering	45
7.5.1	DFSENS and DFTHRH Parameters.	45
7.5.2	Setting the Digital Filter Parameters	45
7.6	Conversion Factors for Secondary Units	45
7.7	Analog Output Calibration	47
7.8	Test Mode	48
7.9	Software Upgrade Instructions.	50
7.10	Software Revision History.	50
7.11	Specifications.	51
	IQ plus 510 Limited Warranty	52

About This Manual

This manual is intended for use by service technicians responsible for installing and servicing IQ plus® 510 digital weight indicators.

This manual applies to indicators using Version 1.4 of the IQ plus 510 software. See Section 7.10 on page 50 for a summary of software changes included in this release.

Configuration and calibration of the indicator can be accomplished using the indicator front panel keys, the EDP command set, or the Revolution Scaleware™ configuration utility. See Section 3.1 on page 13 for information about configuration methods.

1.0 Introduction

The IQ plus 510 is a single-channel digital weight indicator housed in a NEMA 4X/IP66-rated stainless steel enclosure. The indicator front panel consists of a five-button keypad with a large, seven-digit, 14-segment, vacuum fluorescent display, two-character dot-matrix annunciator field, and a sixteen-character dot-matrix prompt field. Features include:

- Drives up to eight 350Ω or sixteen 700Ω load cells
- Supports 4- and 6-wire load cell connections
- Eight configurable digital inputs
- Electronic data processing (EDP) port for full duplex RS-232 or RS-485 communications at up to 19200 bps
- Printer port for output-only RS-232 and 20 mA current loop communications at up to 19200 bps
- Optional analog output module provides 0–10 VDC or 4–20 mA tracking of gross or net weight values
- Optional Remote I/O Interface for communication with PLC™ and SLC™ controllers using the Allen-Bradley® Remote I/O® networks¹
- Available in 115 VAC and 230 VAC versions

The IQ plus 510 is NTEP-certified for Classes III and III L at 10,000 divisions. See Section 7.11 on page 51 for detailed specifications.

1. Allen-Bradley®, PLC®, and SLC™ are trademarks of Allen-Bradley Company, Inc., a Rockwell International company.



Warning

Some procedures described in this manual require work inside the indicator enclosure. These procedures are to be performed by qualified service personnel only.



Authorized distributors and their employees can view or download this manual from the Rice Lake Weighing Systems distributor site at www.rlws.com.

The *Operator Card* included with this manual provides basic operating instructions for users of the IQ plus 510. Please leave the *Operator Card* with the indicator when installation and configuration are complete.

1.1 Operating Modes

The IQ plus 510 has three modes of operation:

Normal (weighing) mode

Normal mode is the “production” mode of the indicator. The indicator shows gross and net weights as required, using the secondary display to indicate scale status and the type of weight value displayed. Once configuration is complete and a legal seal is affixed to the back of the indicator, this is the only mode in which the IQ plus 510 can operate.

Setup mode

Most of the procedures described in this manual require the indicator to be in setup mode, including configuration and calibration.

To enter setup mode, remove the large fillister head screw from the enclosure backplate. Insert a screwdriver or a similar tool into the access hole and press the setup switch once. The indicator display changes to show the word *CONFIG*.

Test mode

Test mode provides a number of diagnostic functions for the IQ plus 510 indicator. Like setup mode, test mode is entered using the setup switch. See Section 7.8 on page 48 for more information about entering and using test mode.

1.2 Front Panel Keypad

The IQ plus 510 display is divided into three areas:

- The primary display consists of seven large, 14-segment digits used to display weight data.
- A two-digit units annunciator shows the units associated with the displayed value: lb=pounds, kg=kilograms, oz=ounces, T=short tons, t=metric tons, LT=long tons,

g=grams, GN=grains. When the units configured are troy pounds or troy ounces, the word **troy** is shown in the secondary display area in addition to the **lb** or **oz** annunciator. The units can also be set to NONE (no units information displayed).

- The 16-digit secondary display is used to display the weighing mode (Gross/Brutto or Net) and status indicators, including standstill (**▲▲**) and center of zero (**►○◄**).

The IQ plus 510 keypad and normal mode key functions are shown in Figure 1-2.

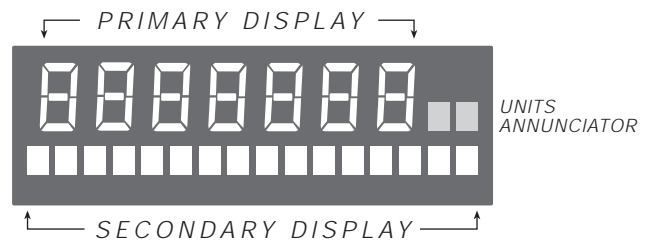

Figure 1-1. IQ plus 510 Front Panel Display Areas

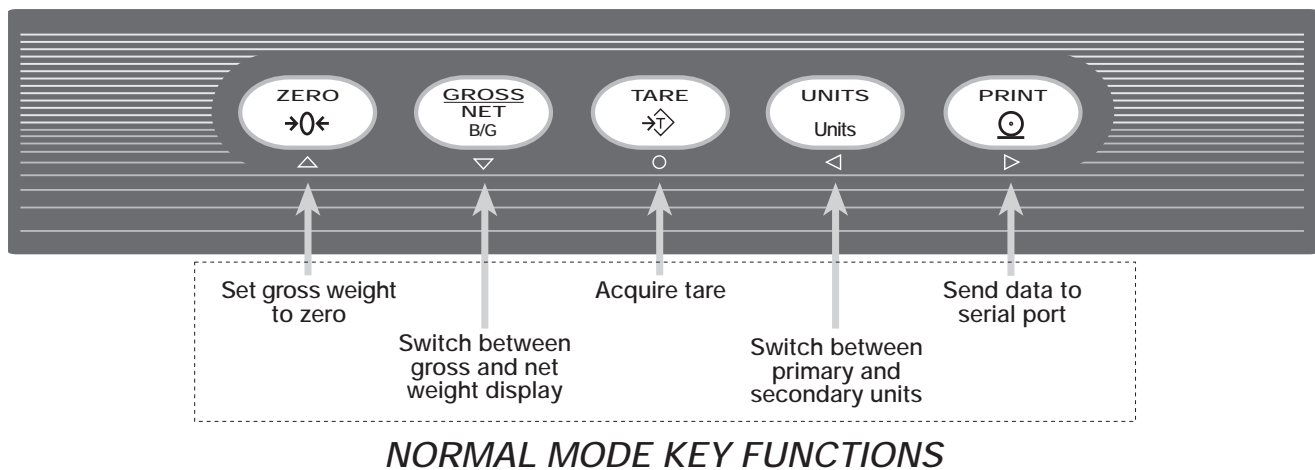

Figure 1-2. Front Panel Key Functions in Normal Mode

1.3 Indicator Operations

Basic IQ plus 510 operations are summarized below:

1.3.1 Toggle Gross/Net Mode

Press the GROSS/NET key to switch the display mode from gross to net, or from net to gross. If a tare value has been entered or acquired, the net value is the gross weight minus the tare. If no tare has been entered or acquired, the display remains in gross mode.

Gross mode is indicated by the word **Gross** (or **Brutto**) on the secondary display; net mode is indicated by the word **Net**.

1.3.2 Toggle Units

Press the UNITS key to switch between primary and secondary units. The units identifier is shown to the right of the primary display. Troy ounces and troy pounds are indicated by the word **troy** on the secondary display.

1.3.3 Zero Scale

1. In gross mode, remove all weight from the scale and wait for the standstill annunciator (**▲▲**).

2. Press the ZERO key. The center of zero (**►○◄**) annunciator lights to indicate the scale is zeroed.

1.3.4 Acquire Tare

1. Place container on scale and wait for the standstill annunciator (**▲▲**).
2. Press the TARE key to acquire the tare weight of the container.
3. Display shifts to net weight and shows the word **Net** on the secondary display.

1.3.5 Remove Stored Tare Value

1. Remove all weight from the scale and wait for the standstill annunciator (**▲▲**).
2. Press the ZERO key. Display shifts to gross weight and shows the word **Gross** on the secondary display.

1.3.6 Print Ticket

1. Wait for the standstill annunciator (**▲▲**).
2. Press the PRINT key to send data to the serial port.

2.0 Installation

This section describes procedures for connecting load cells, digital inputs, and serial communications cables to the IQ plus 510 indicator. Instructions for field installation of the analog output option and replacement of the CPU board are included, along with assembly drawings and parts lists for the service technician.

Caution

- Use a wrist strap to ground yourself and protect components from electrostatic discharge (ESD) when working inside the indicator enclosure.
- This unit uses double pole/neutral fusing which could create an electric shock hazard. Procedures requiring work inside the indicator must be performed by qualified service personnel only.

2.1 Unpacking and Assembly

Immediately after unpacking, visually inspect the IQ plus 510 to ensure all components are included and undamaged. The shipping carton should contain the indicator with attached tilt stand, this manual, and a parts kit. If any parts were damaged in shipment, notify Rice Lake Weighing Systems and the shipper immediately.

The parts kit contains the items listed below:

- Capacity and identification labels.
- Two 8-32NC x 7/16 fillister head screws (PN 30623). These screws occupy the holes above and on either side of the setup screw on the indicator backplate (see Figure 2-2 on page 6).
- Ten 8-32NC x 3/8 machine screws (PN 14862) for the indicator backplate (see #29 in Figure 2-6 on page 12).
- Twelve bonded sealing washers (PN 45042) for backplate screws included in the parts kit.
- Four cord grip reducing glands (PN 15664).
- Four rubber bumpers (“feet”) for the tilt stand, PN 42149.
- 6 cable ties, PN 15631.

2.2 Enclosure Disassembly

The indicator enclosure must be opened to connect cables for load cells, communications, digital inputs, and analog output.



Warning

The IQ plus 510 has no on/off switch. Before opening the unit, ensure the power cord is disconnected from the power outlet.

Ensure power to the indicator is disconnected, then place the indicator face-down on an antistatic work mat. Remove the screws that hold the backplate to the enclosure body, then lift the backplate away from the enclosure and set it aside.

2.3 Cable Connections

The IQ plus 510 provides five cord grips for cabling into the indicator: one for the power cord, four to accommodate load cell, communications, digital inputs, and analog output cables. Three of the four free cord grips come with a plug installed to prevent moisture from entering the enclosure. Depending on your application, remove the plug from any cord grip that will be used and install cables as required.

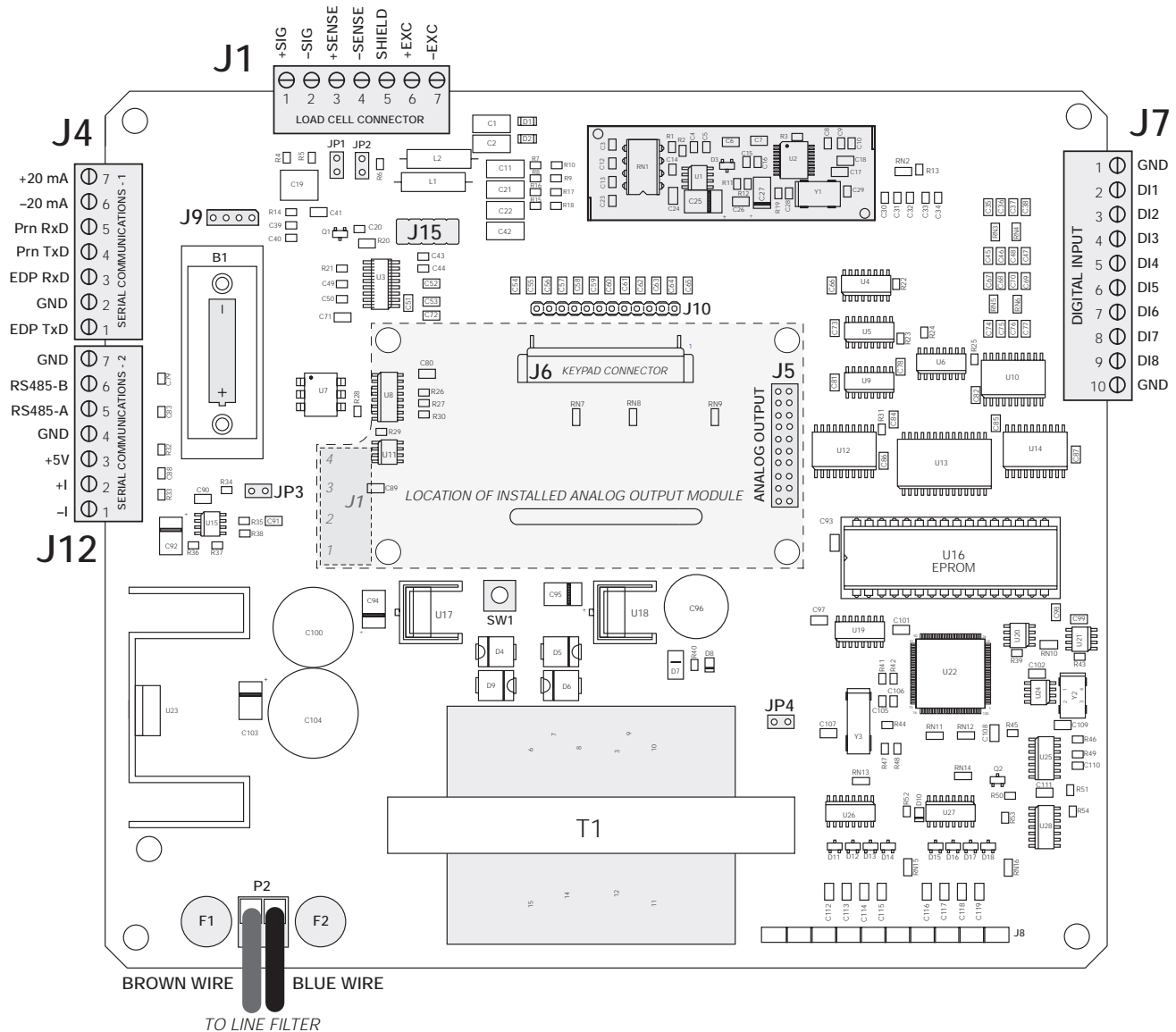

Figure 2-1. IQ plus 510 CPU and Power Supply Board, Rev. 2

2.3.1 Load Cells

To attach cable from a load cell or junction box, remove connector J1 from the board. The connector plugs into a header on the board (see Figure 2-1).

Wire the load cell cable from the load cell or junction box to connector J1 as shown in Table 2-1. If using 6-wire load cell cable (with sense wires), remove jumpers JP1 and JP2 before reinstalling connector J1 (see Figure 2-1). For 4-wire installation, leave jumpers JP1 and JP2 on.

When connections are complete, reinstall connector J1 on the board. Use cable ties to secure the load cell cable to the inside of the enclosure.

J1 Pin	Function
1	+SIG
2	-SIG
3	+SENSE
4	-SENSE
5	SHIELD
6	+EXC
7	-EXC

For 6-wire load cell connections, remove jumpers JP1 and JP2.

Table 2-1. J1 Pin Assignments

2.3.2 Serial Communications

To attach serial communications cables, remove connector J4 or J12 from the board. Connector J4 provides connections for the EDP (Electronic Data Processing) port, printer port, and 20 mA current loop transmit signals; connector J12 provides RS-485 and 20 mA current loop receive signals. Table 2-2 shows the pin assignments for connectors J12 and J4.

Once cables are attached, reconnect J12 or J4 to the header on the board. Use cable ties to secure serial cables to the inside of the enclosure.

The EDP port supports RS-232 or RS-485 communications; the printer port provides active 20 mA output and RS-232 transmission. Both ports are configured using the SERIAL menu. See Section 3.0 on page 13 for configuration information.

Connector	Pin	Signal
J4	1	EDP TxD
	2	GND
	3	EDP RxD
	4	Printer TxD
	5	Printer RxD
	6	-20 mA TxD
	7	+20 mA TxD
J12	1	-I (-20 mA RxD)
	2	+I (+20 mA RxD)
	3	+5V
	4	GND
	5	RS485-A
	6	RS485-B
	7	GND

Table 2-2. J4 and J12 Pin Assignments

2.3.3 Digital Inputs

Digital inputs can be set to provide several indicator functions, including all keypad functions. The inputs are active (on) with low voltage (0 VDC) and can be driven by TTL or 5V logic without additional hardware. Use the DIG IN menu to configure the digital inputs.

Table 2-3 shows the pin assignments for connector J7.

J7 Pin	Signal
1	GND
2	DI1
3	DI2
4	DI3
5	DI4
6	DI5
7	DI6
8	DI7
9	DI8
10	GND

Table 2-3. J7 Pin Assignments (Digital Inputs)

2.3.4 Analog Output

If the optional analog output module is installed, attach the output cable to connector J1 on the analog output board. Table 2-4 lists the analog output pin assignments.

Use the ALGOUT menu to configure and calibrate the analog output module when cabling is complete. See Section 2.4 for information about installing the analog output module.

Pin	Signal
1	+ Current Out
2	- Current Out
3	+ Voltage Out
4	- Voltage Out

Table 2-4. Analog Output Module Pin Assignments

2.4 Analog Output Module Installation

To install or replace the analog output module, follow the steps listed in Section 2.2 on page 3 for opening the IQ plus 510 enclosure.

Mount the analog output module on its standoffs in the location shown in Figure 2-1 on page 4 and plug the module input into connector J5 on the IQ plus 510 board. Connect output cable to the analog output module as shown in Table 2-4, then reassemble the enclosure (Section 2.5).

See Section 7.7 on page 47 for analog output calibration procedures.

2.5 Enclosure Reassembly

Once cabling is complete, position the backplate over the enclosure and reinstall the backplate screws. Use the torque pattern shown in Figure 2-2 to prevent distorting the backplate gasket. Torque screws to 10 in-lb (1.13 N-m).

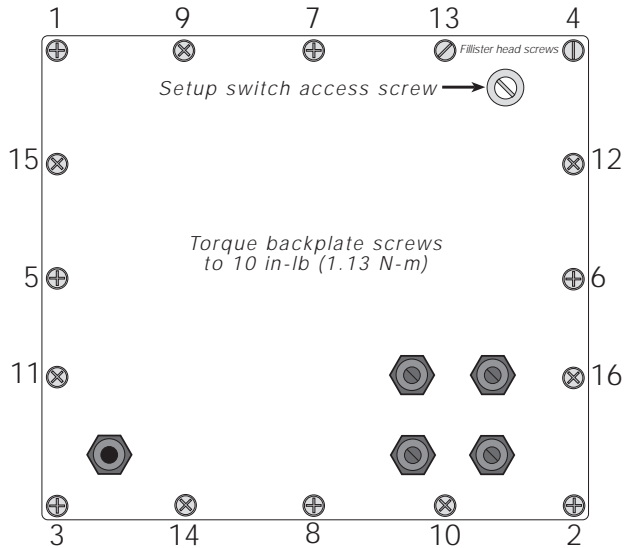

Figure 2-2. IQ plus 510 Enclosure Backplate

2.6 Board Removal

If you must remove the IQ plus 510 CPU board, use the following procedure:

1. Disconnect power to the indicator. Loosen cord grips and remove backplate as described in Section 2.2 on page 3.
2. Unplug connectors J1 (load cell cable), J4 and J12 (serial communications), J7 (digital inputs), J6 (keypad ribbon cable), and JP4 (setup switch). If an analog output board is installed, disconnect the analog output cable. See Figure 2-1 on page 4 for connector locations.
3. Remove the standoff and three nuts from the corners of the CPU board.
4. Cut the cable tie that holds the line filter load wires to the enclosure.
5. Lift the board off of its spacers just far enough to access the setscrews that secure the line filter load wires at connector P2. Use a small screwdriver to loosen the setscrews and disconnect power to the board.
6. Remove the CPU board from the enclosure.

To replace the CPU board, reverse the above procedure. Be sure to reinstall cable ties to secure all cables inside the indicator enclosure.

2.7 Battery Replacement

The 3.0V lithium battery on the power supply/display board maintains the real-time clock and protects data stored in the system RAM when the indicator is not connected to AC power.

System RAM data includes time and date, print formats, truck ID storage, and setpoint configuration. This information is lost if the battery loses power and the indicator is disconnected from AC power. To prevent loss of data, do the following:

- Periodically check the battery voltage and replace when the voltage drops. The battery should last a minimum of one year.
- Use the Revolution™ Scaleware configuration utility or EDP commands (see Section 5.2 on page 36) to store a copy of the indicator configuration on a PC before attempting battery replacement. If any data is lost, the indicator configuration can be restored from the PC.

2.8 Replacement Parts

Table 2-5 lists replacement parts for the IQ plus 510, including all parts referenced in Figures 2-3 through 2-6.

Ref Number	PN	Description (Quantity)	Figure
1	41397	Enclosure, sloped front (1)	Figure 2-6 on page 12
	41401	Enclosure, flat front (1)	
2	41398	Enclosure backplate (1)	Figure 2-3 on page 9
3	14626	Kep nuts, 8-32NC hex (13)	Figure 2-6 on page 12
4	30375	Nylon seal rings for cable grips (4)	Figure 2-3 on page 9
5	14621	Kep nuts, 6-32NC hex (4-flat enclosure; 6-sloped)	Figure 2-5 on page 11
6	15626	Cable grips, PG9 (4)	Figure 2-3 on page 9
7	15627	Locknuts, PCN9 (4)	
8	15650*	Cable tie mounts (8)	Figure 2-4 on page 10
10	19538	Cable grip plugs (3)	Figure 2-3 on page 9
11	44676	Sealing washer for setup switch access screw (1)	
12	42640	Setup switch access screw, 1/4 x 28NF x 1/4 (1)	
13	41965	Power cord assembly, 115VAC (1)	
	45254	Power cord assembly, 230VAC (1)	
15	16892	Ground/Earth Label (1)	Figure 2-4 on page 10
16	45402	Bezel, sloped front (1)	Figure 2-6 on page 12
	41399	Bezel, flat front (1)	
17	41385	Switch panel membrane (1)	Figure 2-6 on page 12
18	41400	Backplate gasket (1)	Figure 2-3 on page 9
19	45043	Ground wire, 4 in w/ No. 8 eye connector (1)	Figure 2-4 on page 10
21	46027	Setup switch mounting bracket (1)	Figure 2-5 on page 11
24	44844	Setup switch assembly (1)	
25	30342	Wing knobs for tilt stand (2)	Figure 2-7 on page 12
26	29635	Tilt stand (1)	
27	15144	Nylon washers for tilt stand, 1/4 x 1 x 1/16 (2)	
28	45891	Line filter assembly (1)	Figure 2-4 on page 10
29	14862*	Screws, 8-32NC x 3/8 (4)	Figure 2-6 on page 12
30	16903	Model/serial number label (1)	—
31	46252	Bezel gasket, sloped front (1)	Figure 2-6 on page 12
	45076	Bezel gasket, flat front (1)	
36	45401	CPU board mounting tab, sloped front models (1)	Figure 2-5 on page 11
37	15134	Lock washers, No. 8 (4)	Figure 2-4 on page 10
38	48027	Nylon spacers for board mounting (4)	Figure 2-5 on page 11
39	45042*	Sealing washers (4)	Figure 2-6 on page 12
40	15369	Standoffs, fem 6-32NC x 3/4 (3)	Figure 2-4 on page 10
41	44539	Display and CPU board assembly, Rev 2, 115 VAC (1)	Figure 2-5 on page 11
	44538	Display and CPU board assembly, Rev 2, 230 VAC (1)	
—	40698	VFD display (1)	
42	19644	3V cylindrical lithium battery	

Table 2-5. Replacement Parts

Ref Number	PN	Description (Quantity)	Figure
—	42104	7-position connectors for J1, J4, and J12 (3)	Figure 2-1 on page 4
—	46420	10-position connector for J7 (1)	
—	45484	160 mA TR5 subminiature fuses (2), 115 VAC	F1 and F2 in Figure 2-1 on page 4
	45107	80 mA TR5 subminiature fuses (2), 230 VAC	
<i>The following parts apply only to units using the Rev 1 CPU board with cable interface board</i>			
9	14839	Machine screw, 6-32NC x 1/4 (4)	<i>Not shown</i>
20	45312	Interface board assembly (1)	
24	45414	Serial cable, interface board to CPU board (1)	
32	45388	Interface board mounting bracket, top (1)	
33	45387	Interface board mounting bracket, side (1)	
* Additional parts included in parts kit.			
 Caution <i>For protection against risk of fire, replace fuses only with same type and rating fuse.</i> See Section 7.11 on page 51 for complete fuse specifications.			

Table 2-5. Replacement Parts (Continued)

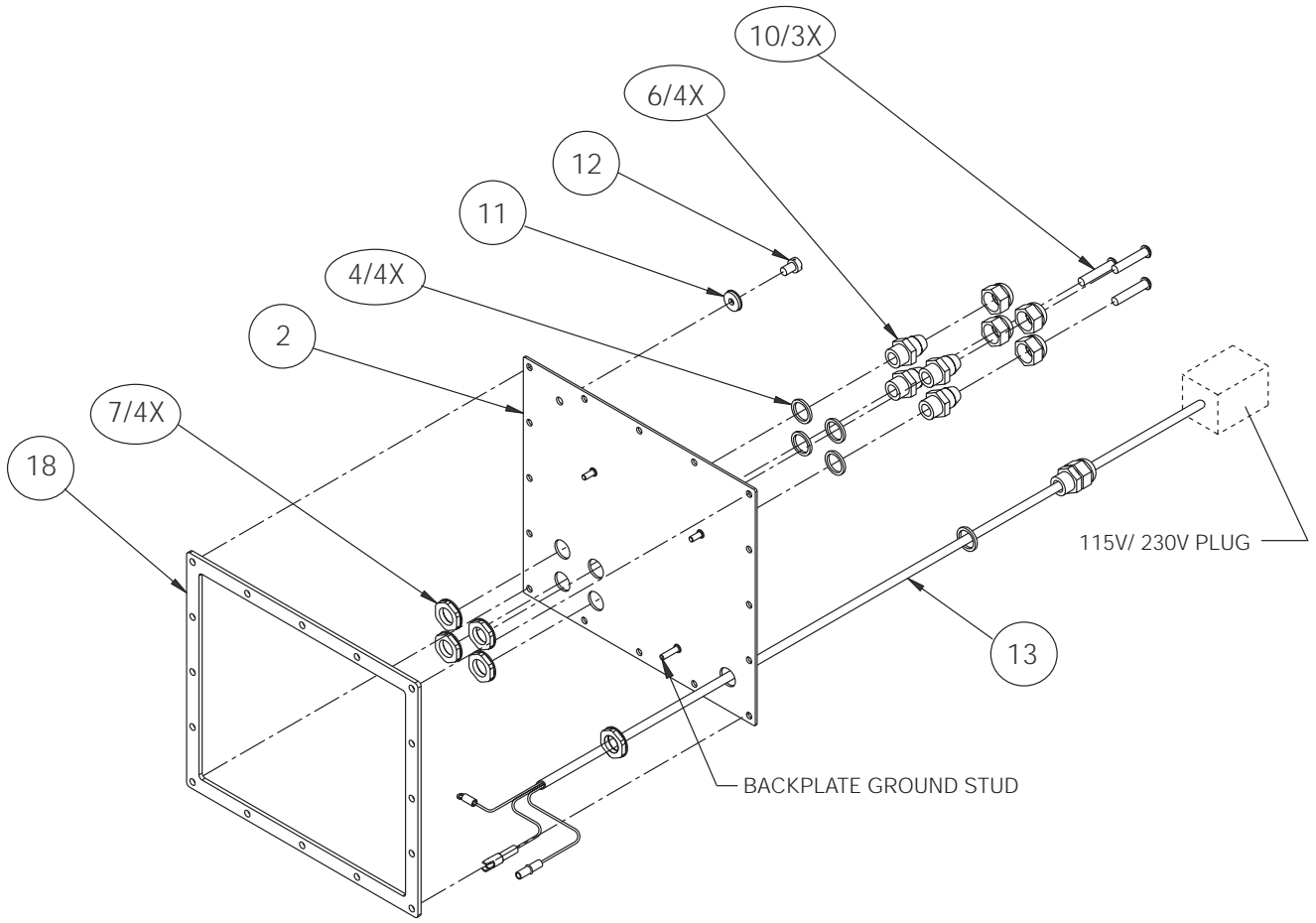

Figure 2-3. Backplate Assembly

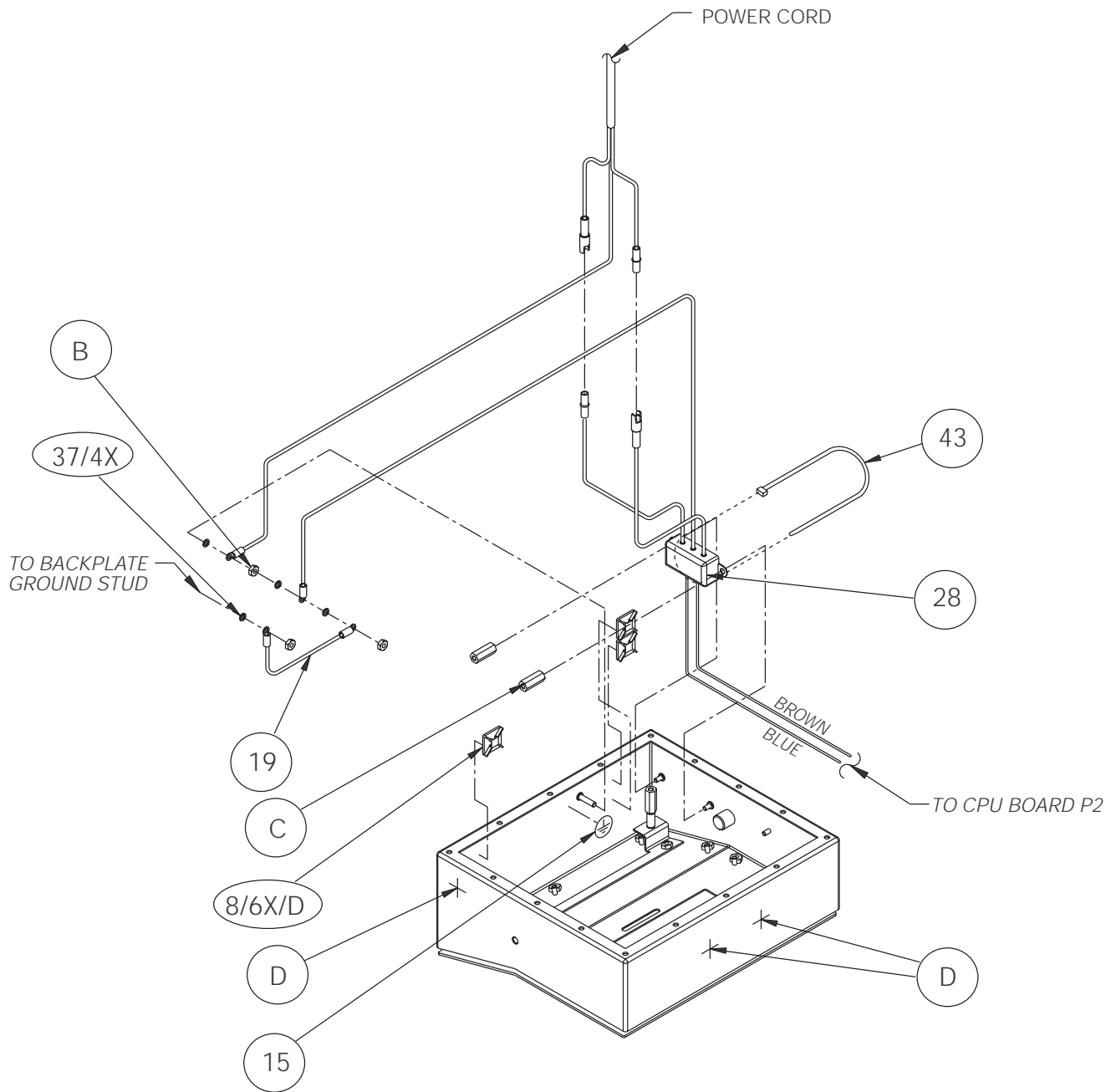

Figure 2-4. Enclosure and Line Filter Assembly

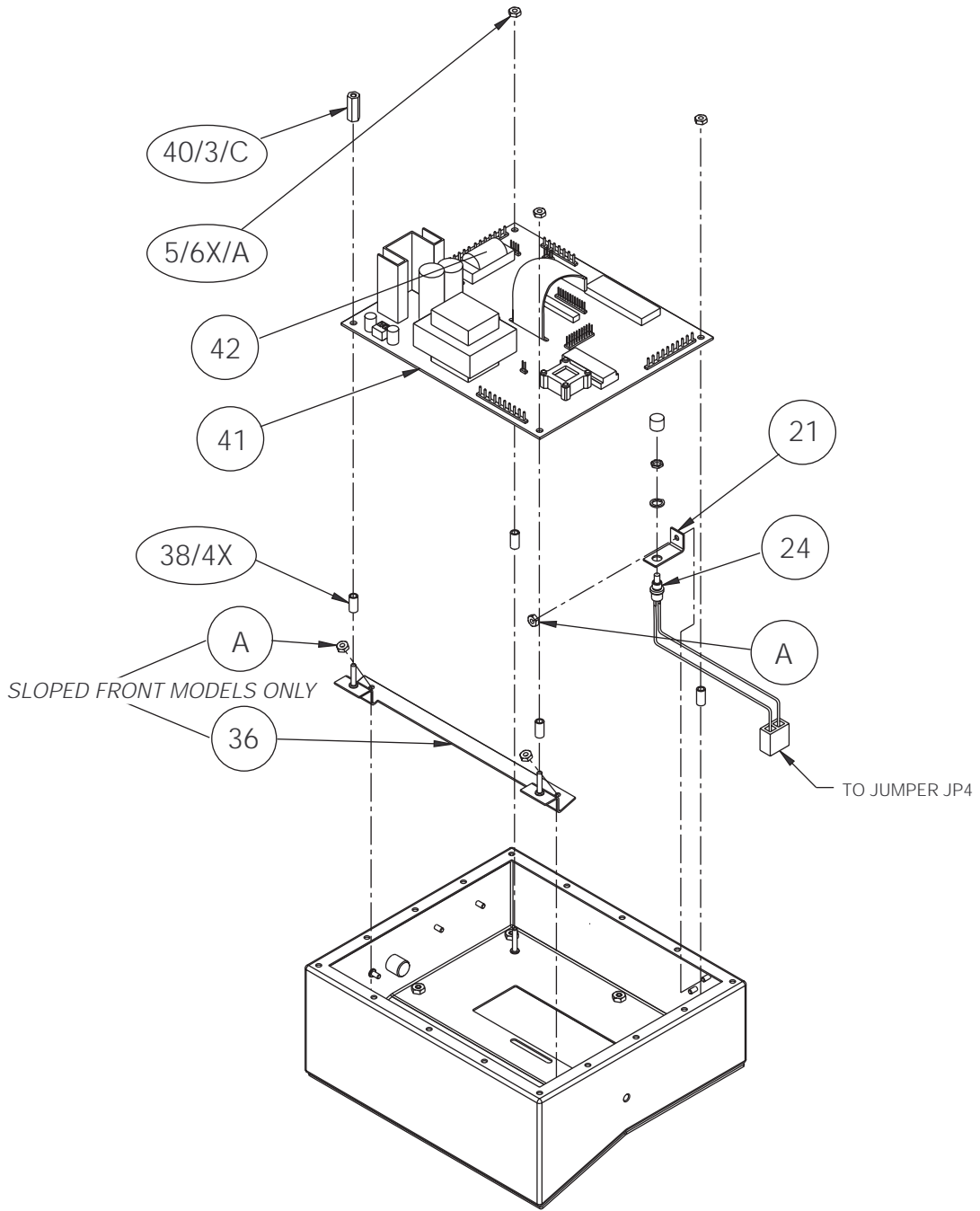

Figure 2-5. Enclosure and CPU Board Assembly

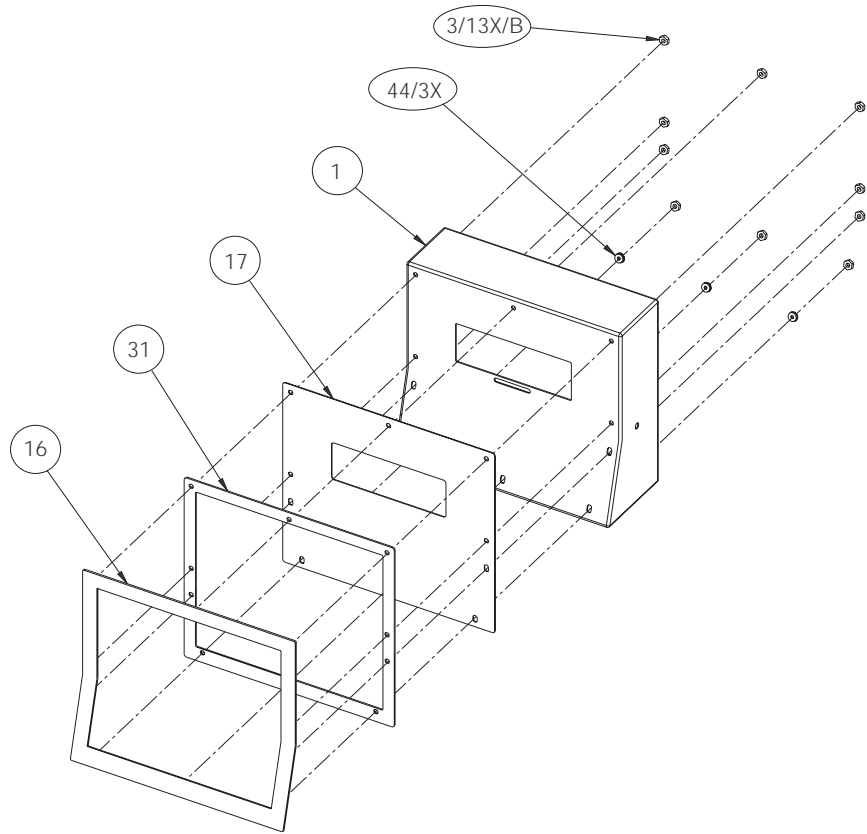

Figure 2-6. Bezel Assembly

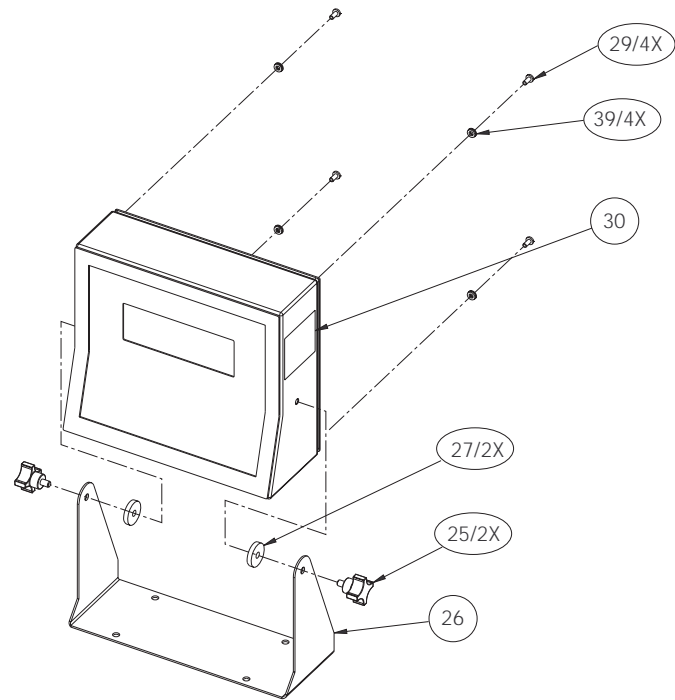

Figure 2-7. Tilt Stand Assembly

3.0 Configuration

To configure the IQ plus 510 indicator, the indicator must be placed in setup mode. The setup switch is accessed by removing the large fillister head screw on the enclosure backplate. Switch position is changed by inserting a screwdriver into the access hole and pressing the switch.

When the indicator is placed in setup mode, the word *CONFIG* is shown on the display. The CONFIG menu is the first of nine main menus used to configure the indicator. Detailed descriptions of these menus are given in Section 3.2. When configuration is complete, return to the CONFIG menu and press the Δ (ZERO) key to exit setup mode, then replace the setup switch access screw.

3.1 Configuration Methods

The IQ plus 510 indicator can be configured by using the front panel keys to navigate through a series of configuration menus or by sending commands or configuration data to the EDP port. Configuration using the menus is described in Section 3.1.3.

Configuration using the EDP port can be accomplished using either the EDP command set described in Section 5.0 or the Revolution™ Scaleware configuration utility.

3.1.1 Revolution™ Scaleware Configuration

The Revolution Scaleware configuration utility provides the preferred method for configuring the IQ plus 510 indicator. Revolution runs on a personal computer to set configuration parameters for the indicator. When Revolution configuration is complete, configuration data is downloaded to the indicator.



Figure 3-1. Sample Revolution Scaleware Configuration Display

Revolution supports both uploading and downloading of indicator configuration data. This capability allows configuration data to be retrieved from one indicator, edited, then downloaded to another.

To use Revolution Scaleware, do the following:

1. Install Revolution on an IBM-compatible personal computer running Windows® 3.11 or Windows 95. Minimum system requirements are 4MB of extended memory and at least 5MB of available hard disk space.
2. With both indicator and PC powered off, connect the PC serial port to the RS-232 pins on the indicator EDP port.
3. Power up the PC and the indicator. Use the setup switch to place the indicator in setup mode.
4. Start the Revolution Scaleware program.

Figure 3-1 shows an example of one of the Revolution Scaleware configuration displays.

Revolution provides online help for each of its configuration displays. Parameter descriptions provided in this manual for front panel configuration can also be used when configuring the indicator using Revolution: the interface is different, but the parameters set are the same.

3.1.2 EDP Command Configuration

The EDP command set can be used to configure the IQ plus 510 indicator using either a personal computer, terminal, or remote keyboard. Like Revolution, EDP command configuration sends commands to the indicator EDP port; unlike Revolution, EDP commands can be sent using any external device capable of sending ASCII characters over a serial connection.

EDP commands duplicate the functions available using the indicator front panel and provide some functions not otherwise available. EDP commands can be used to simulate pressing front panel keys, to configure the indicator, or to dump lists of parameter settings. See Section 5.0 on page 31 for more information about using the EDP command set.

3.1.3 Front Panel Configuration

The IQ plus 510 indicator can be configured using a series of menus accessed through the indicator front panel when the indicator is in setup mode. Table 3-1 summarizes the functions of each of the main menus.

Menu		Menu Function
CONFIG	Configuration	Configure grads, zero tracking, zero range, motion band, overload, tare function, power-up mode, and digital filtering parameters.
FORMAT	Format	Set format of primary and secondary units, decimal format, and display rate.
CALIBR	Calibration	Calibrate indicator. See Section 4.0 on page 28 for calibration procedures.
SERIAL	Serial	Configure EDP and printer serial ports.
PROGRM	Program	Set date and time formats, keyboard locks, regulatory mode, and consecutive number values.
PFORMAT	Print Format	Set print format used for header, gross, net, and EDP format tickets. See Section 6.0 for more information.
DIG IN	Digital Input	Assign digital input functions.
ALGOUT	Analog Output	Configure analog output module. Used only if analog output option is installed.
VERSION	Version	Display installed software version number.

Table 3-1. IQ plus 510 Menu Summary

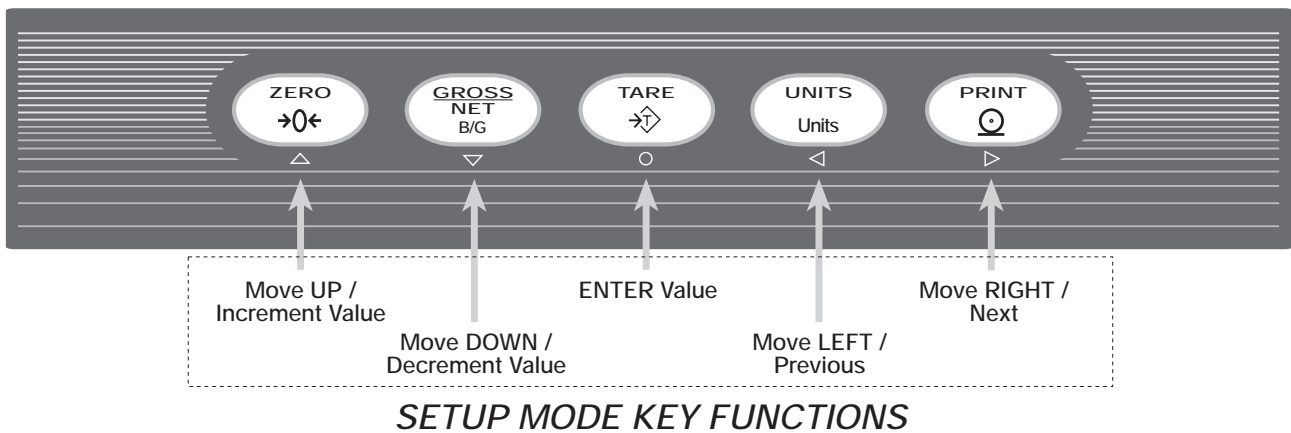
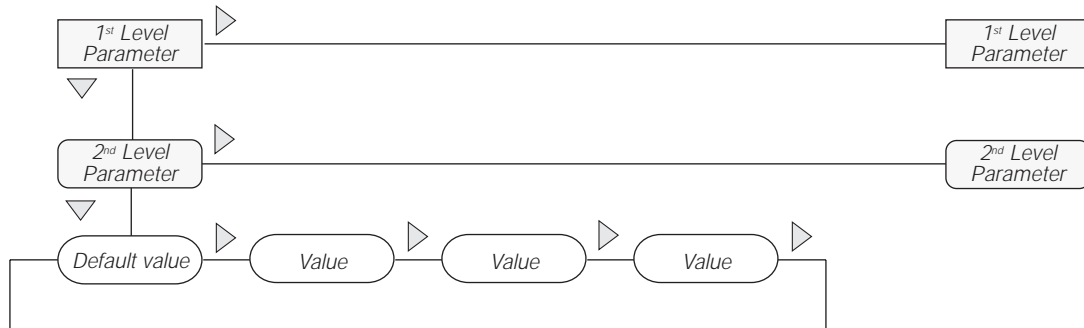

Figure 3-2. Front Panel Key Functions in Setup Mode

Four front panel keys are used as directional keys to navigate through the menus in setup mode (see Figure 3-2). The UNITS (◀) and PRINT (▶) keys scroll left and right (horizontally) on the same menu level; ZERO (▲) and GROSS/NET (▼) move up and down (vertically) to different menu levels. The TARE key (○) serves as an Enter key for selecting parameter values within the menus. A label under each of these keys identifies the direction provided by the key when navigating through the setup menus.



When moving through values below the first menu level, press ▲ to return to the level above. Press ○ or ▼ to move to the next parameter on the level above.

Figure 3-3. Setup Mode Menu Navigation

To select a parameter, press ◀ or ▶ to scroll left or right until the desired menu group appears on the display, then press ▼ to move down to the submenu or parameter you want. When moving through the menu parameters, the default or previously selected value appears first on the display.

To change a parameter value, scroll left or right to view the values for that parameter. When the desired value appears on the display, press ○ to select the value and move back up one level. To edit numerical values, use the navigation keys to select the digit and to increment or decrement the value (see Figure 3-4).



When editing numeric values, press ◀ or ▶ to change the digit selected. Press ▲ or ▼ to increment or decrement the value of the selected digit.

Press ○ to save the value entered and return to the level above.

Figure 3-4. Editing Procedure for Numeric Values

3.2 Menu Structures and Parameter Descriptions

The following sections provide graphic representations of the IQ plus 510 menu structures. In the actual menu structure, the values you choose under each parameter are arranged horizontally. To save page space, menu choices are shown in vertical columns. Default values are shown in bold type at the top of each column.

Most menu diagrams are accompanied by one or more tables that describe all parameters and parameter values associated with that menu option. Default parameter values are shown in bold type.

3.2.1 Configuration Menu

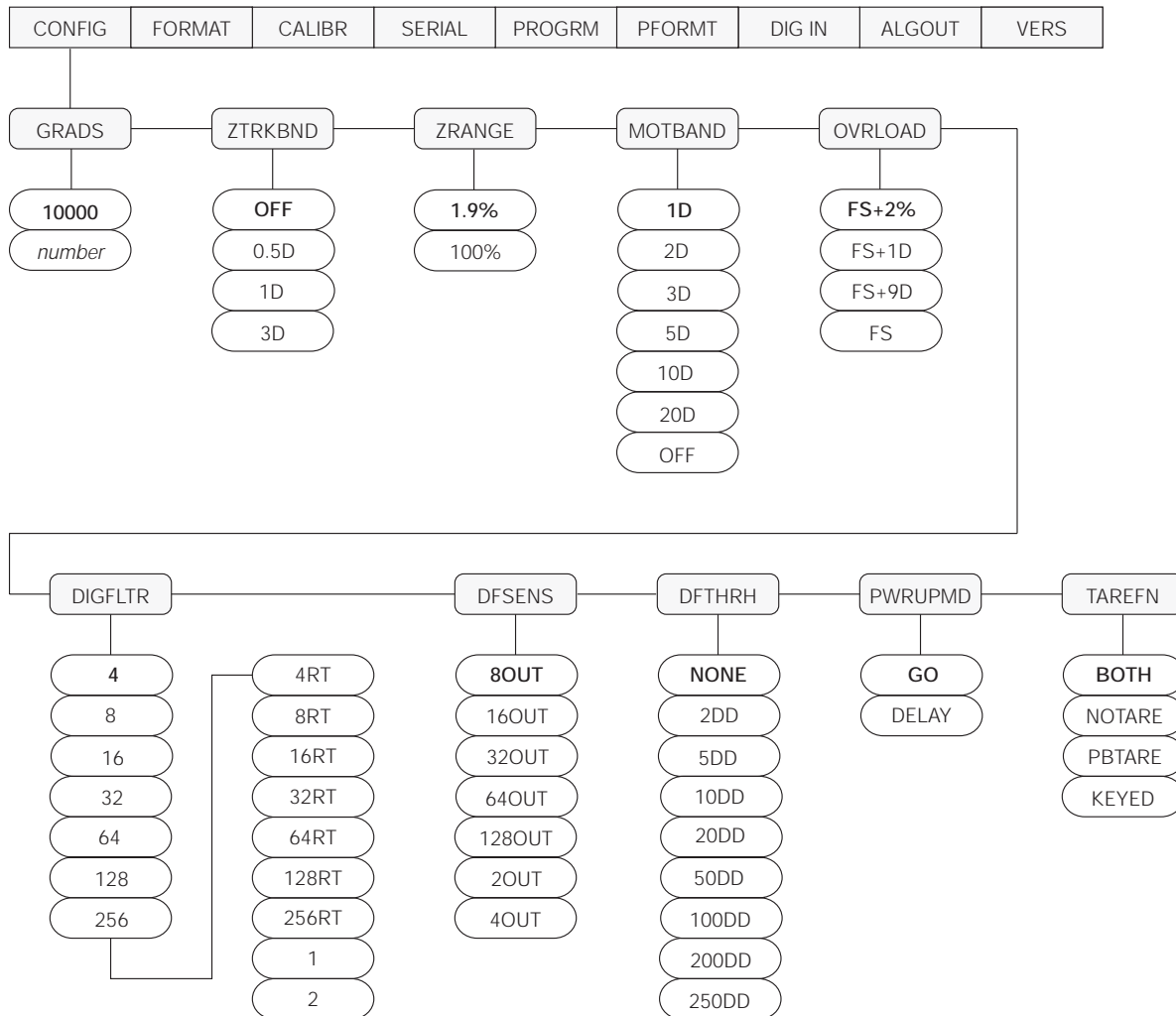

Figure 3-5. Configuration Menu

CONFIG Menu		
Parameter	Choices	Description
<i>Level 2 submenus</i>		
GRADS	10000 <i>number</i>	Specifies the number of full scale graduations. The value entered must be in the range 1–100000 and should be consistent with legal requirements and environmental limits on system resolution. To calculate GRADS, use the formula, $GRADS = Capacity / Display Divisions$. Display divisions for primary and secondary units are specified on the FORMAT menu.
ZTRKBND	OFF 0.5D 1D 3D	Automatically zeroes the scale when within the range specified, as long as the input is within the ZRANGE and scale is at standstill. Selections are ± display divisions. Maximum legal value varies depending on local regulations.

Table 3-2. Configuration Menu Parameters

CONFIG Menu		
Parameter	Choices	Description
ZRANGE	1.9% 100%	Selects the range within which the scale can be zeroed. The 1.9% selection is $\pm 1.9\%$ around the calibrated zero point, for a total range of 3.8%. Indicator must be at standstill to zero the scale. Use 1.9% for legal-for-trade applications.
MOTBAND	1D 2D 3D 5D 10D 20D OFF	<p>Sets the level, in display divisions, at which scale motion is detected. If motion is not detected for 1 second or more, the standstill symbol lights. Some operations, including print, tare, and zero, require the scale to be at standstill. Maximum legal value for this parameter varies depending on local regulations.</p> <p>If this parameter is set to OFF, the standstill annunciator will not light; operations normally requiring standstill (zero, tare, print) are performed regardless of scale motion. If OFF is selected, ZTRKBND must also be set to OFF.</p>
OVRLOAD	FS+2% FS+1D FS+9D FS	Determines the point at which the display blanks and an out-of-range error message is displayed. Maximum legal value varies depending on local regulations.
DIGFLTR	4 8 16 32 64 128 256 4RT 8RT 16RT 32RT 64RT 128RT 256RT 1 2	<p>Selects the digital filtering rate used to reduce the effects of mechanical vibration from the immediate area of the scale.</p> <p>Choices indicate the number of A/D conversions per update that are averaged to obtain the displayed reading. A higher number gives a more accurate display by minimizing the effect of a few noisy readings, but slows down the settling rate of the indicator.</p>
DFSENS	8OUT 16OUT 32OUT 64OUT 128OUT 2OUT 4OUT	Digital filter cutout sensitivity. Specifies the number of consecutive readings that must fall outside the filter threshold (DFTHRH parameter) before digital filtering is suspended.
DFTHRH	NONE 2DD 5DD 10DD 20DD 50DD 100DD 200DD 250DD	Digital filter cutout threshold. Specifies the filter threshold, in display divisions. When a specified number of consecutive scale readings (DFSENS parameter) fall outside of this threshold, digital filtering is suspended.
PWRUPMD	GO DELAY	<p>Power up mode. In GO mode, the indicator goes into operation immediately after a brief power up display test.</p> <p>In DELAY mode, the indicator performs a power up display test, then enters a 30-second warm up period. If no motion is detected during the warm up period, the indicator becomes operational when the warm up period ends; if motion is detected, the delay timer is reset and the warm up period repeated.</p>

Table 3-2. Configuration Menu Parameters (Continued)

CONFIG Menu		
Parameter	Choices	Description
TAREFN	BOTH NOTARE PBTARE KEYED	Enables or disables push-button and keyed tares. Possible values are: BOTH: Both push-button and keyed tares are enabled NOTARE: No tare allowed (gross mode only) PBTARE: Push-button tares enabled KEYED: Keyed tare enabled

Table 3-2. Configuration Menu Parameters (Continued)

3.2.2 Format Menu

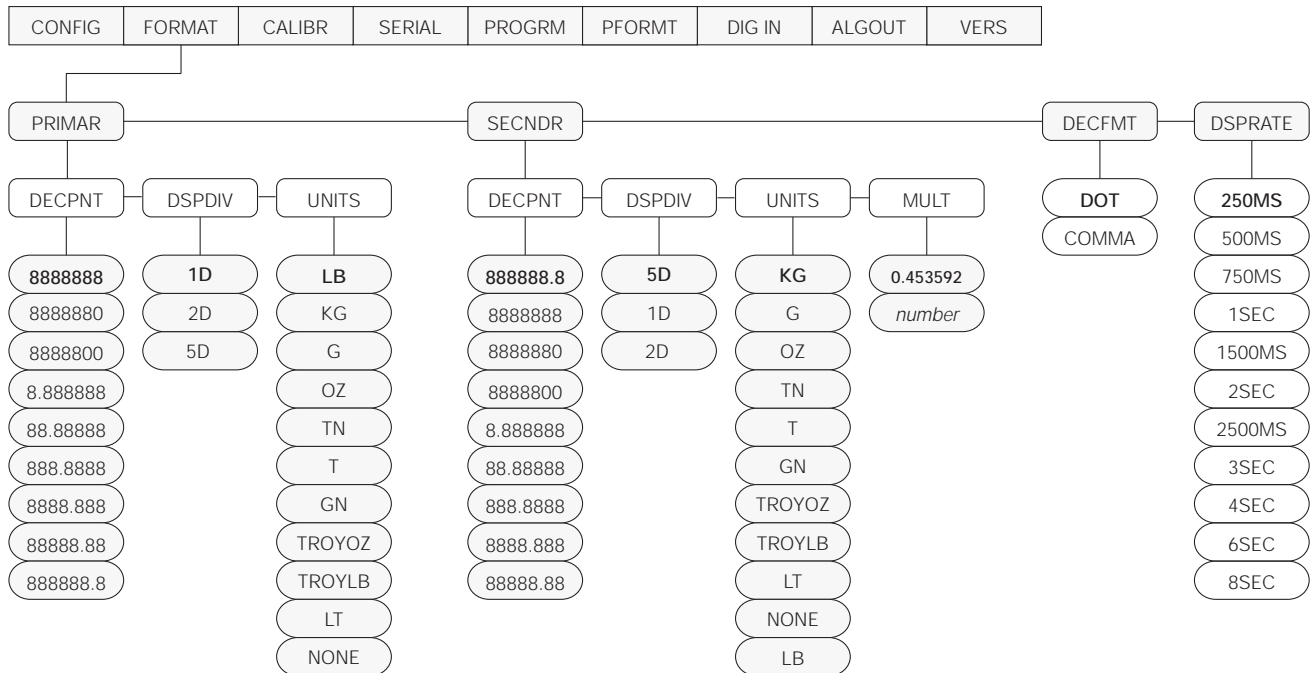

Figure 3-6. Format Menu

FORMAT Menu		
Parameter	Choices	Description
<i>Level 2 submenus</i>		
PRIMAR	DECPNT DSPDIV UNITS	Specifies the decimal position, display divisions, and units used for the primary units. See Level 3 submenu parameter descriptions.
SECNDR	DECPNT DSPDIV UNITS MULT MULEXP	Specifies the decimal position, display divisions, units, and conversion multiplier used for the secondary units. See Level 3 submenu parameter descriptions.
DEC FMT	DOT COMMA	Specifies whether decimal numbers are displayed using a period (DOT) or comma as the decimal symbol.

Table 3-3. Format Menu Parameters

FORMAT Menu		
Parameter	Choices	Description
DSPRATE	250MS 500MS 750MS 1SEC 1500MS 2SEC 2500MS 3SEC 4SEC 6SEC 8SEC	Display rate. Sets the update rate for displayed values. Values are in milliseconds (MS) or seconds (SEC).
<i>Level 3 submenus</i>		
Primary Units (PRIMAR Parameter)		
DECPNT	8888888 8888880 8888800 8.888888 88.88888 888.8888 8888.888 88888.88 888888.8	Decimal point location. Specifies the location of the decimal point or dummy zeroes in the primary unit display. Value should be consistent with local legal requirements.
DSPDIV	1D 2D 5D	Display divisions. Selects the minimum division size for the primary units displayed weight.
UNITS	LB KG G OZ TN T GN TROYOZ TROYLB LT NONE	Specifies primary units for displayed and printed weight. Values are: LB=pound; KG=kilogram; G=gram; OZ=ounce; TN=short ton; T=metric ton; GN=grain; TROYOZ=troy ounce; TROYLB=troy pound; LT=long ton. NOTE: Units sold outside North America are configured with KG for both primary and secondary units.
Secondary Units (SECNDR Parameter)		
DECPNT	888888.8 8888888 8888880 8888800 8.888888 88.88888 888.8888 8888.888 88888.88	Decimal point location. Determines the location of the decimal point or dummy zeros in the display.
DSPDIV	5D 1D 2D	Display divisions. Selects the value of minimum division size of the displayed weight.

Table 3-3. Format Menu Parameters (Continued)

FORMAT Menu		
Parameter	Choices	Description
UNITS	KG G OZ TN T GN TROYOZ TROYLB LT NONE LB	Specifies primary units for displayed and printed weight. Values are: LB=pound; KG=kilogram; G=gram; OZ=ounce; TN=short ton; T=metric ton; GN=grain; TROYOZ=troy ounce; TROYLB=troy pound; LT=long ton.
MULT	0.453592 <i>Enter other choices via keyboard</i>	Multiplier. Specifies the conversion factor by which the primary units are multiplied to obtain the secondary units. The default is 0.453592, which is the conversion factor for changing pounds to kilograms. For multiplier values of 10 or more, use the MULEXP parameter to shift the decimal position of the multiplier. See Section 7.6 on page 45 for a list of multipliers. To toggle between primary and secondary units, press the UNITS key.
MULEXP	<i>decimal position</i>	Multiplier exponent. Sets the decimal position for multiplier values of 10 or more.

Table 3-3. Format Menu Parameters (Continued)

3.2.3 Calibration Menu

See Section 4.0 on page 28 for calibration procedures.

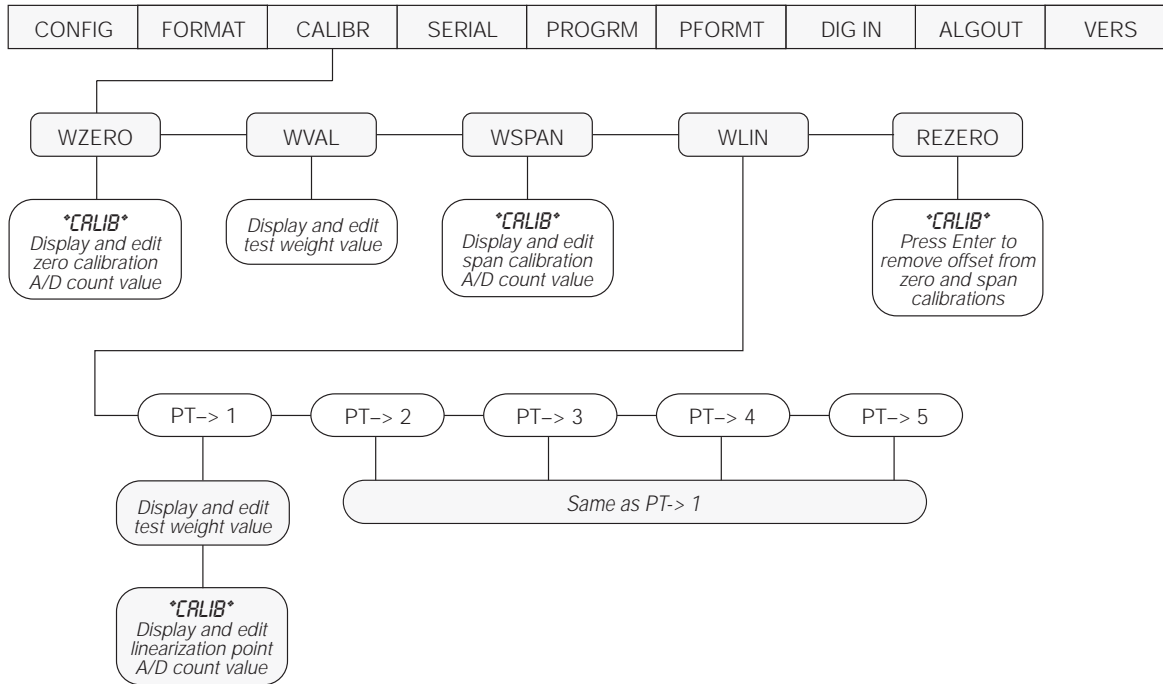

Figure 3-7. Calibration Menu

CALIBR Menu		
Parameter	Choices	Description
<i>Level 2 submenus</i>		
WZERO	—	Display and edit the zero calibration A/D count value.
WWAL	—	Display and edit the test weight value.
WSPAN	—	Display and edit the span calibration A/D count value.
WLIN	PT->1 — PT->5	Display and edit test weight and calibration values for up to five linearization points.
REZERO	—	Press Enter to remove an offset value from the zero and span calibrations.

Table 3-4. Calibration Menu Parameters

3.2.4 Serial Menu

See Section 7.3 on page 42 for information about IQ plus 510 serial data formats.

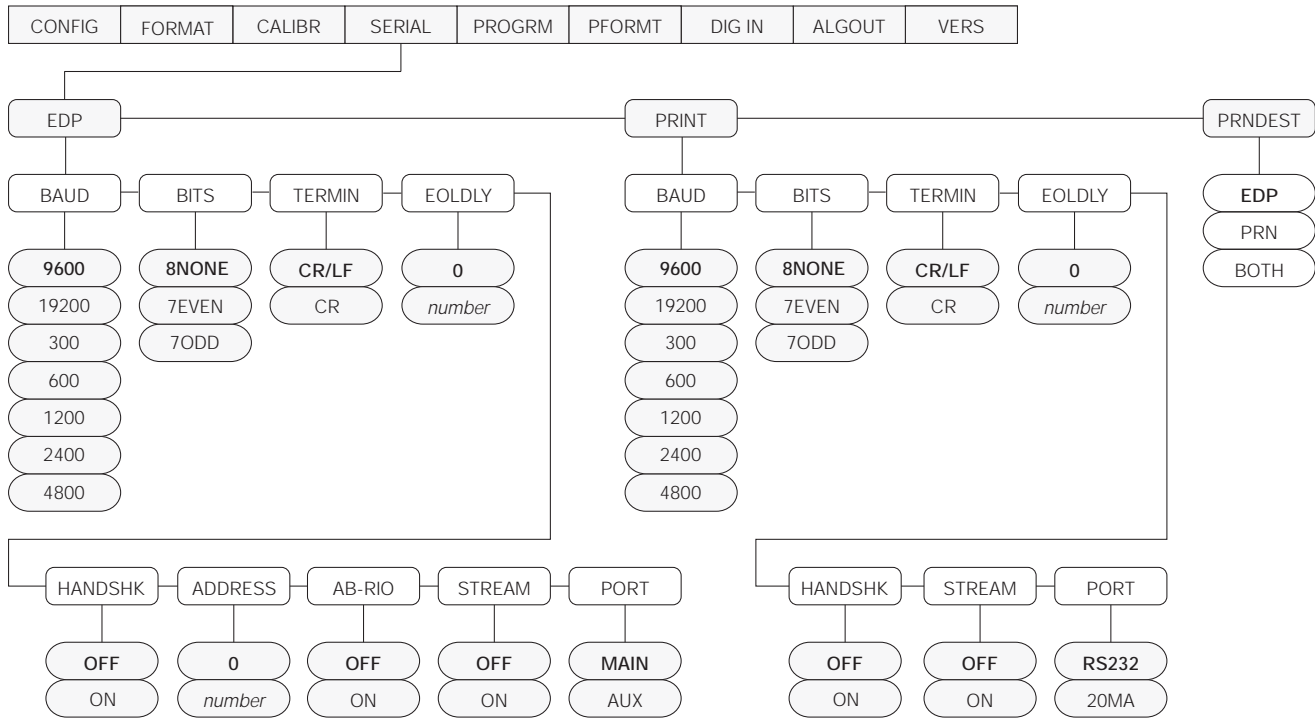

Figure 3-8. Serial Menu

SERIAL Menu		
Parameter	Choices	Description
<i>Level 2 submenus</i>		
EDP	BAUD BITS TERMIN EOLDLY HANDSHK ADDRESS AB-RIO STREAM PORT	Configure the EDP port. See Level 3 submenu parameter descriptions.
PRINT	BAUD BITS TERMIN EOLDLY HANDSHK STREAM PORT	Configure the printer port. See Level 3 submenu parameter descriptions.
PRNDEST	EDP PRN BOTH	Print destination. Selects the port for data transmission when the PRINT key is pressed or the KPRINT EDP command is sent.

Table 3-5. Serial Menu Parameters

SERIAL Menu		
Parameter	Choices	Description
Level 3 Submenus		EDP Port
BAUD	9600 19200 300 600 1200 2400 4800	Baud rate. Selects the transmission speed for the EDP port.
BITS	8NONE 7EVEN 7ODD	Selects number of data bits and parity of data transmitted from the EDP port.
TERMIN	CR/LF CR	Termination character. Selects termination character for data sent from the EDP port.
EOLDLY	0 <i>number</i>	End-of-line delay. Sets the delay period, in 0.1-second intervals, from when a formatted line is terminated to the beginning of the next formatted serial output. Value specified must be in the range 0-255, in tenths of a second (10 = 1 second).
HANDSHK	OFF ON	Specifies whether XON/XOFF flow control characters are used.
ADDRESS	0 <i>address</i>	Specifies the decimal indicator address for RS-485 connections. RS-232 communications is disabled if an address other than zero is specified for this parameter. RS-485 addresses must be in the range 01–255.
AB-RIO	OFF ON	Specifies whether the EDP uses the Allen-Bradley Remote I/O data stream. Specify ON only if the Remote I/O option is installed.
STREAM	OFF ON	Specifies whether data is streamed from the EDP port.
PORT	MAIN AUX	<i>Reserved for future use.</i>
Level 3 Submenus		Printer Port
BAUD	9600 19200 300 600 1200 2400 4800	Baud rate. Selects the transmission speed for the printer port.
BITS	8NONE 7EVEN 7ODD	Selects number of data bits and parity of data transmitted from the printer port.
TERMIN	CR/LF CR	Termination character. Selects termination character for data sent from the printer port.
EOLDLY	0 <i>number</i>	End-of-line delay. Sets the delay period, in 0.1-second intervals, from when a formatted line is terminated to the beginning of the next formatted serial output. Value specified must be in the range 0-255, in tenths of a second (10 = 1 second).
HANDSHK	OFF ON	Specifies whether XON/XOFF flow control characters are used.
STREAM	OFF ON	Specifies whether data is streamed from the printer port.
PORT	RS232 20MA	<i>Reserved for future use.</i>

Table 3-5. Serial Menu Parameters (Continued)

3.2.5 Program Menu

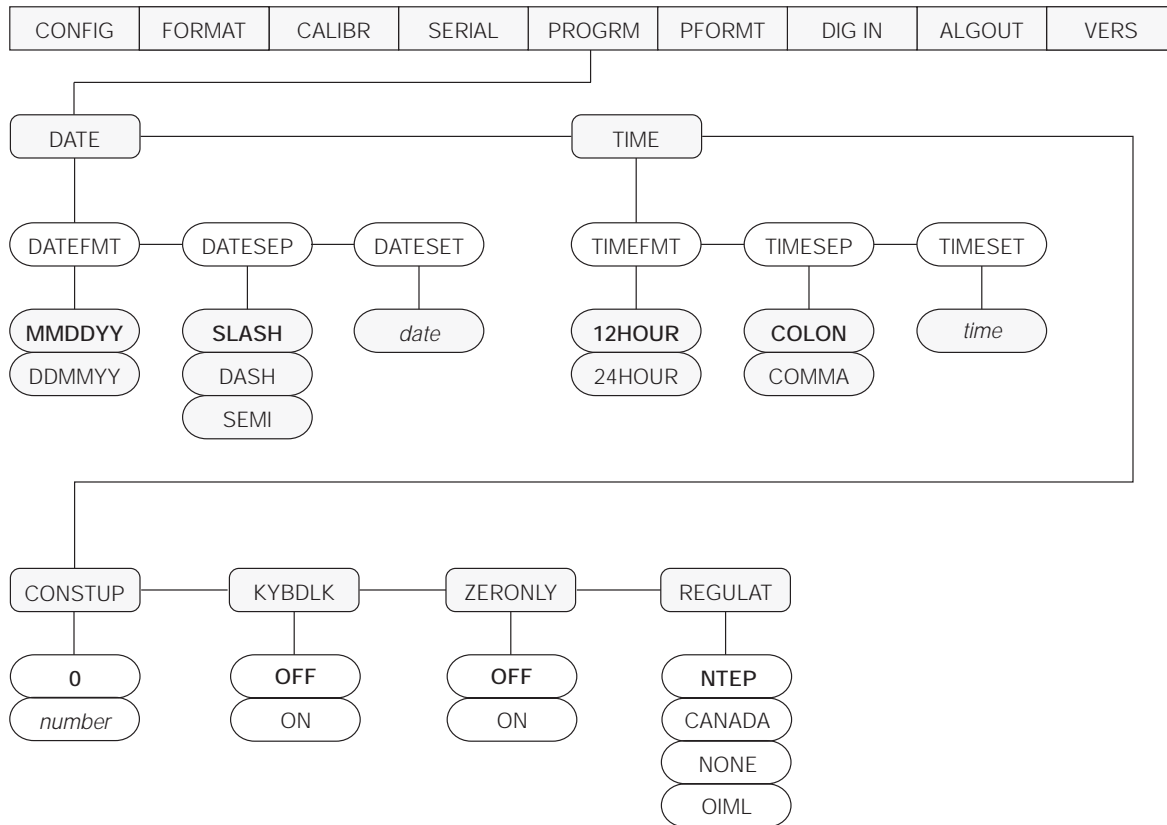

Figure 3-9. Program Menu

PROGRM Menu		
Parameter	Choices	Description
<i>Level 2 submenus</i>		
DATE	DATEFMT DATESEP DATESET	Allows selection of date format and date separator character. See Level 3 submenu parameter descriptions. Use the DATESET parameter or the SD EDP command to set the date. See Section 5.0 on page 31 for information about using the EDP commands.
TIME	TIMEFMT TIMESEP TIMESET	Allows selection of time format and separator character. See Level 3 submenu parameter descriptions. Use the TIMESET parameter or the ST EDP command to set the time. See Section 5.0 on page 31 for information about using the EDP commands.
CONSTUP	0 number	Specifies the initial consecutive number value used when the indicator is reset. Value specified must be in the range 0–9 999 999.
KYBDLK	OFF ON	Keyboard lock. Specify ON to disable the keypad in normal mode.
ZERONLY	OFF ON	Zero key only. Specify ON to disable all front panel keys except ZERO in normal mode.

Table 3-6. Program Menu Parameters

PROGRM Menu		
Parameter	Choices	Description
REGULAT	NTEP OIML NONE CANADA	Regulatory mode. Specifies the regulatory agency having jurisdiction over the scale site. OIML and CANADA modes require the scale load to be at zero before clearing a tare; OIML mode replaces the <i>Gross</i> annunciator with <i>Brutto</i> .
<i>Level 3 submenus</i>		
DATEFMT	MMDDYY DDMMYY	Specifies the format used to display or print the date.
DATESEP	SLASH DASH SEMI	Specifies the date separator character.
DATESET	MMDDYY DDMMYY	Specifies the current date. Use the numeric editing procedure shown in Figure 3-4 on page 15 to enter the date in the format specified on the DATEFMT parameter (MMDDYY or DDMMYY).
TIMEFMT	12HOUR 24HOUR	Specifies the format used to display or print the time.
TIMESEP	COLON COMMA	Specifies the time separator character.
TIMESET	hhmm	Specifies the current time. Use the numeric editing procedure shown in Figure 3-4 on page 15 to enter the time in the format specified on the TIMEFMT parameter (12- or 24-hour).

Table 3-6. Program Menu Parameters (Continued)

3.2.6 Print Format Menu

See Section 6.0 on page 37 for information about custom print formatting.

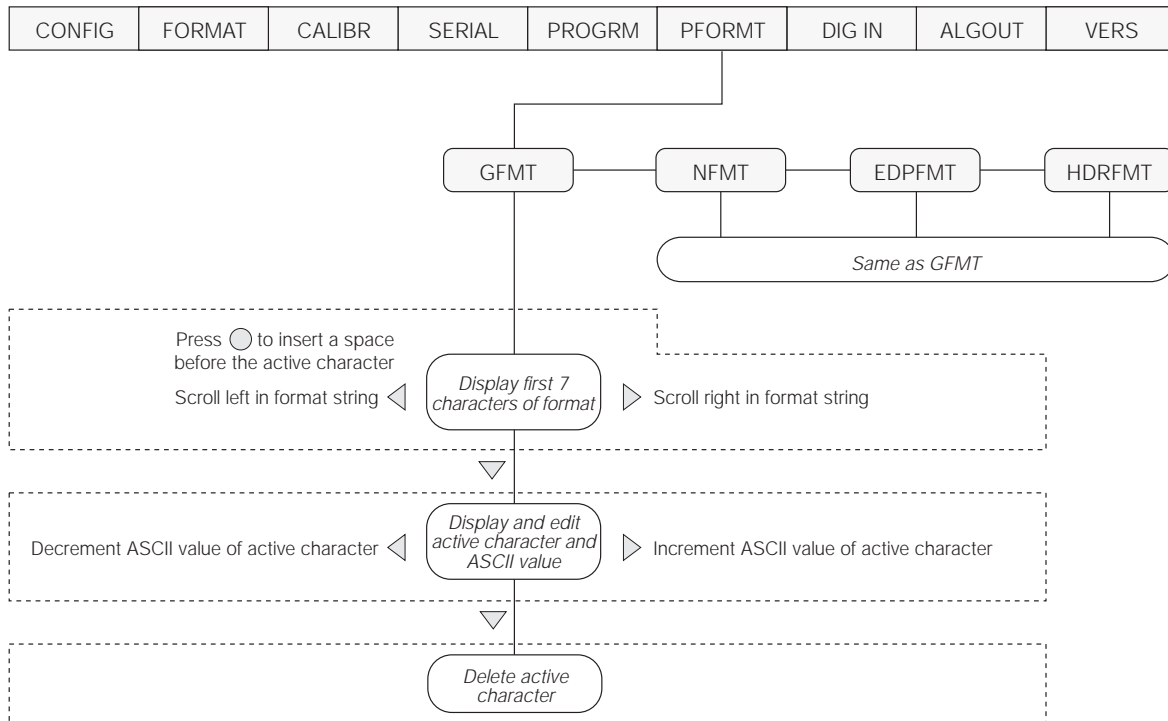

Figure 3-10. Print Format Menu

3.2.7 Digital Input Menu

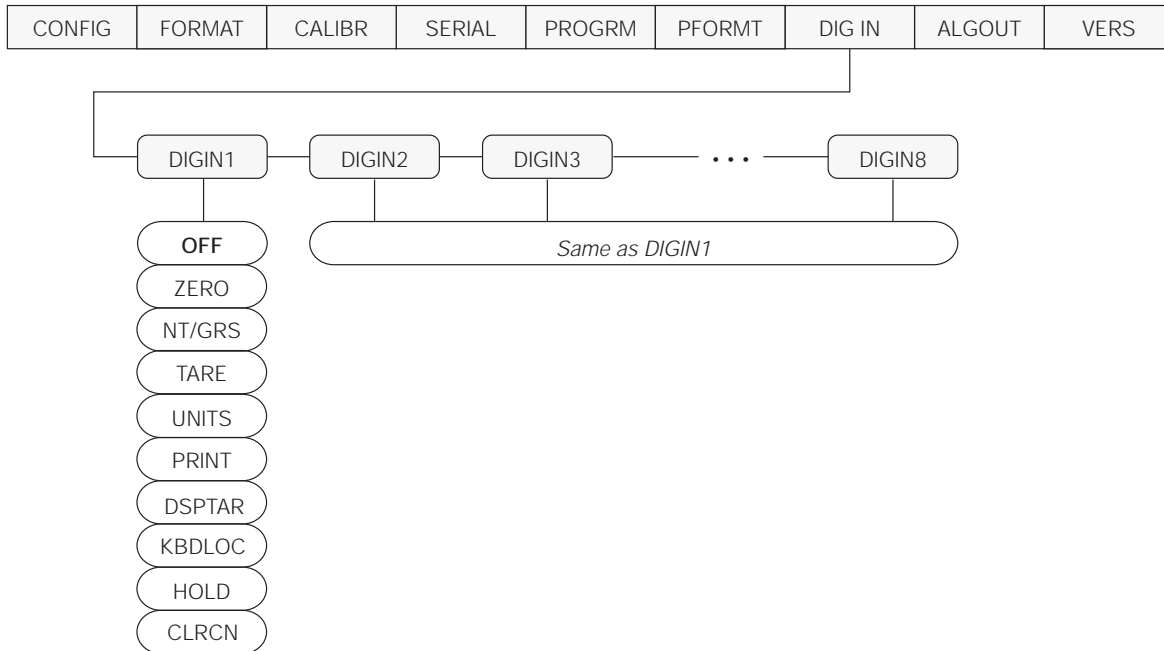

Figure 3-11. Digital Input Menu

DIG IN Menu		
Parameter	Choices	Description
<i>Level 2 submenus</i>		
DIGIN1 DIGIN2 DIGIN3 DIGIN4 DIGIN5 DIGIN6 DIGIN7 DIGIN8	OFF ZERO NT/GRS TARE UNITS PRINT DSPTAR KBDLOC HOLD CLRCN	Specifies the function activated by digital inputs 1–8. <ul style="list-style-type: none"> • ZERO, NT/GRS (net/gross mode toggle), TARE, UNITS, and PRINT provide the same functions as the front panel keys. DSPTAR displays the current tare value. • KBDLOC locks the keyboard (indicator front panel) while the digital input is held low. • HOLD holds the current display. Releasing this input clears the running average filter. • CLRCN resets the consecutive number to the value specified on the CONSTUP parameter (PROGRAM menu).

Table 3-7. Digital Input Menu Parameters

3.2.8 Analog Output Menu

The ALGOUT menu is used only if the analog output option is installed. If the analog output option is installed, configure all other indicator functions and calibrate the indicator before configuring the analog output. See Section 7.7 on page 47 for analog output calibration procedures.

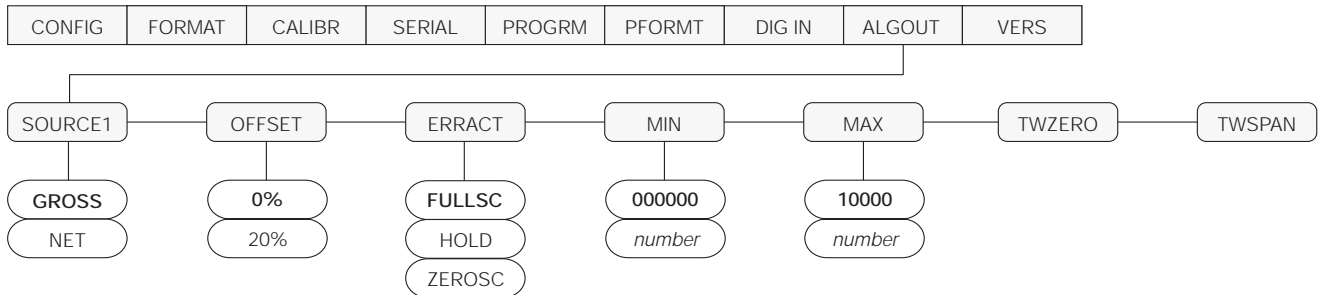

Figure 3-12. Analog Output Menu

ALG OUT Menu		
Parameter	Choices	Description
<i>Level 2 submenus</i>		
SOURCE1	GROSS NET	Specifies the source tracked by the analog output.
OFFSET	0% 20%	Zero offset. Selects whether the analog output supplies voltage (0–10 V) or current (4–20 mA) output. Select 0% for 0–10 V output; select 20% for 4–20 mA output.
ERRACT	FULLSC HOLD ZEROSC	Error action. Specifies how the analog output responds to system error conditions. Possible values are: FULLSC: Set to full value (10 V or 20 mA) HOLD: Hold current value ZEROSC: Set to zero value (0 V or 4 mA)
MIN	000000 number	Specifies the minimum weight value tracked by the analog output. Specify a value in the range 0–9999800.
MAX	010000 number	Specifies the maximum weight value tracked by the analog output. Specify a value in the range 0–9999800.
TWZERO	—	Tweak zero. Adjust the analog output zero calibration. Use a multimeter to monitor the analog output value. Press and hold Δ or ∇ to adjust the output.
TWSPAN	—	Tweak span. Adjust the analog output span calibration. Use a multimeter to monitor the analog output value. Press and hold Δ or ∇ to adjust the output.

Table 3-8. Analog Output Menu Parameters

3.2.9 Version Menu

The VERS menu is used to check the software version installed in the indicator. There are no parameters associated with the Version menu: when selected, the indicator displays the installed software version number.

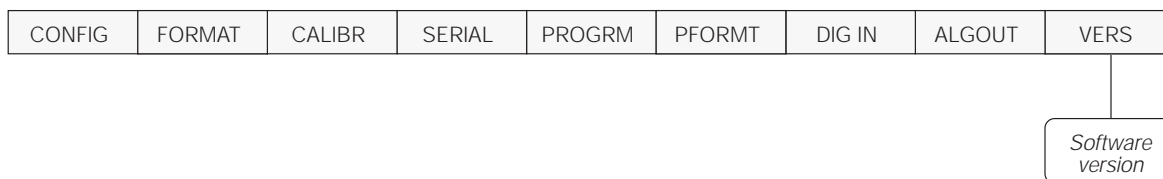

Figure 3-13. Version Menu

4.0 Calibration

The IQ plus 510 can be calibrated using the front panel, EDP commands, or the Revolution™ Scaleware configuration utility. Each method consists of the following steps:

- Zero calibration
- Entering the test weight value
- Span calibration
- Optional five-point linearization
- Optional rezero calibration for test weights using hooks or chains.

The following sections describe the calibration procedure for each of the calibration methods.

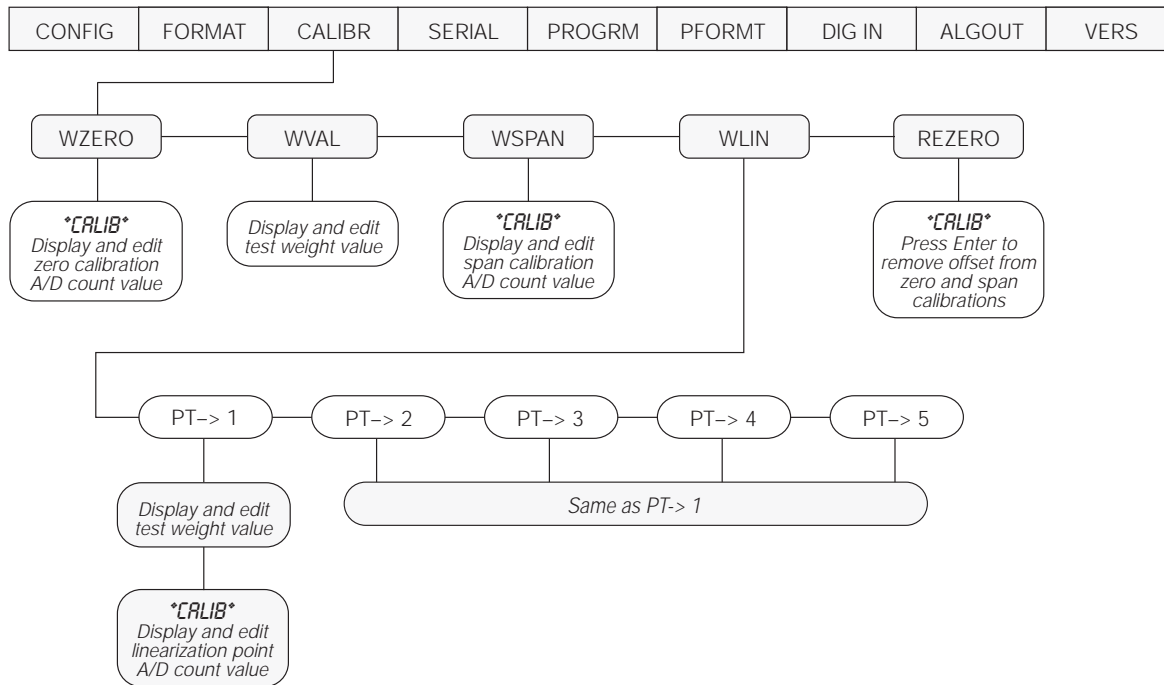

Figure 4-1. Calibration (CALIBR) Menu

4.1 Front Panel Calibration

To calibrate the indicator using the front panel, do the following:

1. Place the indicator in setup mode (display reads *CONFIG*) and remove all weight from the scale platform. If your test weights require hooks or chains, place the hooks or chains on the scale for zero calibration.
2. Press \blacktriangleright until the display reads *CALIBR* (see Figure 4-1). Press \blacktriangledown to go to zero calibration (*WZERO*).
3. With *WZERO* displayed, press \bigcirc to calibrate zero. The indicator displays **CAL** while calibration is in progress. When complete, the A/D count for the zero calibration is displayed. Press \bigcirc again to save the zero calibration value and go to the next prompt (*WVAL*).
4. With *WVAL* displayed, place test weights on the scale and press \bigcirc to show the test weight value. Use the procedure shown in Figure 4-2 to enter the actual test weight, then press \bigcirc to save the value and go to span calibration (*WSPAN*).
5. With *WSPAN* displayed, press \bigcirc to calibrate span. The indicator displays **CAL** while calibration is in progress. When complete, the A/D count for the span calibration is displayed. Press \bigcirc again to save the span calibration value and go to the next prompt (*WLIN*).
6. Five-point linearization (using the *WLIN* parameter) provides increased scale accuracy by calibrating the indicator at up to five additional points between the zero and span calibrations.

Linearization is optional: if you choose not to perform linearization, skip the `WLIN` parameter; if linearization values have previously been entered, use the procedure shown in Figure 4-2 to set each point to zero then press `ENTER`. To perform linearization, follow the procedure below:

With `WLIN` displayed, Press `▽` to go to the first linearization point (`PT-> 1`). Place test weights on the scale and press `○` or `ENTER`.

Use the procedure shown in Figure 4-2 to enter the actual test weight value, then press `ENTER` to calibrate. The indicator displays `*CAL*` while calibration is in progress. When complete, the A/D count for the linear calibration is displayed. Press `ENTER` again to save the calibration value and go to the next prompt (`PT-> 2`).



When editing numeric values, press `◀` or `▶` to change the digit selected. Press `▲` or `▼` to increment or decrement the value of the selected digit.

Press `○` to save the value entered and return to the level above.

Figure 4-2. Editing Procedure for Numeric Values

Repeat for up to five linearization points. To exit the linearization parameters, press `△` to return to `WLIN`.

7. The rezero function is used to remove a calibration offset when hooks or chains are used to hang the test weights.
 - If no other apparatus was used to hang the test weights during calibration, remove the test weights and press `△` to return to the `CALIBR` menu.
 - If hooks or chains were used during calibration, remove these and the test weights from the scale. With all weight removed, press `○` to rezero the scale. This function adjusts the zero and span calibration values. The indicator displays `*CAL*` while the zero and span calibrations are adjusted. When complete, the adjusted A/D count for the zero calibration is displayed. Press `○` to save the value, then press `△` to return to the `CALIBR` menu.
8. Press `◀` until the display reads `CONFIG`, then press `△` to exit setup mode.

4.2 EDP Command Calibration

To calibrate the indicator using EDP commands, the indicator EDP port must be connected to a terminal or personal computer. See Section 2.3.2 on page 5 for EDP port pin assignments; see Section 5.0 on page 31 for more information about using EDP commands.

Once the indicator is connected to the sending device, do the following:

1. Place the indicator in setup mode (display reads `CONFIG`) and remove all weight from the scale platform. If your test weights require hooks or chains, place the hooks or chains on the scale for zero calibration.
2. Send the `WZERO` EDP command to calibrate zero. The indicator displays `*CAL*` while calibration is in progress.
3. Place test weights on the scale and use the `WVAL` command to enter the test weight value in the following format:
`WVAL=nnnnn<CR>`
4. Send the `WSPAN` EDP command to calibrate span. The indicator displays `*CAL*` while calibration is in progress.

5. Up to five linearization points can be calibrated between the zero and span calibration values. Use the following commands to set and calibrate a single linearization point:

```
WLIN.V1=nnnn<CR>
WLIN.C1<CR>
```

The `WLIN.V1` command sets the test weight value (`nnnnn`) for linearization point 1. The `WLIN.C1` command calibrates the point. Repeat using the `WLIN.Vx` and `WLIN.Cx` commands as required for additional linearization points.

6. To remove an offset value, clear all weight from the scale, including hooks or chains used to hang test weights, then send the `REZERO` EDP command. The indicator displays `*CAL*` while the zero and span calibrations are adjusted.
7. Send the `KUPARROW` or `KEXIT` EDP command to exit setup mode.

4.3 Revolution™ Scaleware Calibration

To calibrate the indicator using Revolution Scaleware, the indicator EDP port must be connected to a PC running the Revolution configuration utility.

Use the following procedure to calibrate the indicator:

1. Place the indicator in setup mode (display reads *CONFIG*) and remove all weight from the scale platform.
2. Select *Calibrate Indicator* from the Revolution Scaleware main menu.
3. On the Indicator Calibration display, select the indicator model (*IQ+510*) and communications port then click *OK*.
4. Revolution Scaleware uploads calibration data from the indicator then presents the information in a display like that shown in Figure 4-3.

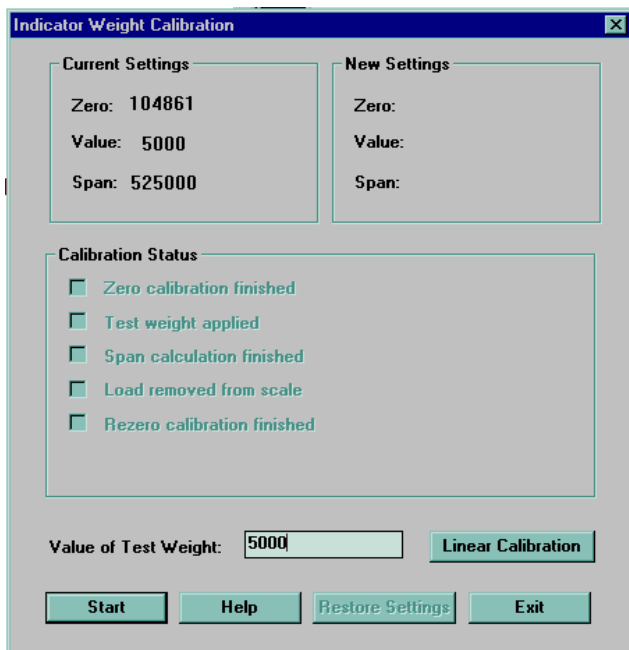

Figure 4-3. Revolution Scaleware Calibration Display

5. Enter the *Value of Test Weight* to be used for span calibration then click *START*.
6. The Zero Calibration dialog box prompts you to remove all weight from the scale. Clear the scale and click *OK* to begin zero calibration. **NOTE:** If your test weights require hooks or chains, place the hooks or chains on the scale for zero calibration.
7. When zero calibration is complete, the Span Calibration dialog box prompts you to place test weights on the scale for span calibration. Place test weights on the scale then click *OK*.
8. When span calibration is complete, the Rezero dialog box prompts you to remove weights from the scale. Remove the weights then click *OK*.
9. When calibration is complete, the *New Settings* fields of the Indicator Calibration display are filled in. Click *Exit* to save the new values and return to the Revolution Scaleware main menu; to restore the previous calibration values, click *Restore Settings*.

5.0 EDP Commands

The IQ plus 510 indicator can be controlled by a personal computer or remote keyboard connected to the indicator EDP port. Control is provided by a set of EDP commands that can simulate front panel key press functions, display and change setup parameters, and perform reporting functions. The EDP port provides the capability to print configuration data or to save that data to an attached personal computer. This section describes the EDP command set and procedures for saving and transferring data using the EDP port.

5.1 The EDP Command Set

The EDP command set can be divided into five groups: key press commands, reporting commands, the RESETCONFIGURATION special function command, parameter setting commands, and transmit weight data commands.

When the indicator processes an EDP command, it responds with the message *OK*. The *OK* response verifies that the command was received and has been executed. If the command is unrecognized or cannot be executed, the indicator responds with *??*.

The following sections list the commands and command syntax used for each of these groups.

5.1.1 Key Press Commands

Key press EDP commands (see Table 5-1) simulate pressing the keys on the front panel of the indicator. These commands can be used in both setup and weighing mode. Several of the commands serve as “pseudo” keys, providing functions that are not represented by a key on the front panel.

For example, to enter a 15-pound tare weight using EDP commands:

1. Type K1 and press ENTER (or RETURN).
2. Type K5 and press ENTER.
3. Type KTARE and press ENTER.

Command	Function
KZERO	Press the ZERO key
KGROSSNET	Press the GROSS/NET key
KGROSS	Go to gross mode (pseudo key)
KNET	Go to net mode (pseudo key)
KTARE	Press the TARE key
KUNITS	Press the UNITS key
KPRIM	Go to primary units (pseudo key)
KSEC	Go to secondary units (pseudo key)
KNEWID	Enter new ID (pseudo key)
KPRINT	Press the PRINT key
KLEFTARROW	In setup mode, move left in the menu; in weighing mode, press the UNITS key
KRIGHTARROW	In setup mode, move right in the menu; in weighing mode, press the PRINT key
KUPARROW	In setup mode, move up in the menu; in weighing mode, press the ZERO key
KDOWNARROW	In setup mode, move down in the menu; in weighing mode, press the GROSS/ NET key
K0	Press number 0 (zero)
K1	Press number 1
K2	Press number 2
K3	Press number 3
K4	Press number 4
K5	Press number 5
K6	Press number 6
K7	Press number 7
K8	Press number 8
K9	Press number 9
KDOT	Press the decimal point (.)
KENTER	Press the ENTER key

Table 5-1. EDP Key Press Commands

5.1.2 Reporting Commands

Reporting commands (see Table 5-2) send specific information to the EDP port. These commands can be used in both setup mode and normal mode.

Command	Function
DUMPALL	List all parameter values
VERSION	Write IQ plus 510 software version
P	Write current displayed weight with units identifier. See Section 7.2 on page 41 for more information.
ZZ	Write current weight and annunciator status. See Section 7.2 on page 41 for more information.
S	Write one frame of stream format

Table 5-2. EDP Reporting Commands

5.1.3 The RESETCONFIGURATION Command

The RESETCONFIGURATION command can be used to restore all configuration parameters to their default values. Before issuing this command, the indicator must be placed in test mode (press and hold setup switch for approximately three seconds to show TEST menu).

This command is equivalent to using the DEFLT function on the TEST menu. See Section 7.8 on page 48 for more information about test mode and using the TEST menu. **NOTE:** All load cell calibration settings are lost when the RESETCONFIGURATION command is run.

5.1.4 Parameter Setting Commands

Parameter setting commands allow you to display or change the current value for a particular configuration parameter (Tables 5-3 through 5-10).

Current configuration parameter settings can be displayed in either setup mode or normal mode using the following syntax:

command<ENTER>

Most parameter values can be changed in setup mode only. Use the following command syntax when changing parameter values:

command= value<ENTER>

where *value* is either a number or a parameter value. Use no spaces before or after the equal (=) sign. If you type an incorrect command, the display reads ??.

For example, to set the motion band parameter to 5, type the following:

MOTBAND=5D<ENTER>

Command	Description	Values
GRADS	Graduations	1-100000
ZTRKBND	Zero track band	OFF, 0.5D, 1D, 3D
ZRANGE	Zero range	1.9%, 100%
MOTBAND	Motion band	1D, 2D, 3D, 5D, 10D, 20D, OFF
OVRLOAD	Overload	FS+2%, FS+1D, FS+9D, FS
DIGFLTR	Digital filtering	1, 2, 4, 8, 16, 32, 64, 128, 256, 1RT, 2RT, 4RT, 8RT, 16RT, 32RT, 64RT, 128RT, 256RT
DFSENS	Digital filter cutout sensitivity	2OUT, 4OUT, 8OT, 16OUT, 32OUT, 64OUT, 128OUT
DFTHRH	Digital filter cutout threshold	NONE, 2DD, 5DD, 10DD, 20DD, 50DD, 100DD, 200DD, 250DD
PWRUPMD	Power up mode	GO, DELAY
TAREFN	Tare function	BOTH, NOTARE, PBTARE, KEYED

Table 5-3. CONFIG EDP Commands

Command	Description	Values
PRI.DECPNT	Primary units decimal position	8.888888, 88.88888, 888.8888, 8888.888, 88888.88, 888888.8, 8888888, 8888880, 8888800
PRI.DSPDIV	Primary units display divisions	1D, 2D, 5D
PRI.UNITS	Primary units	LB, KG, G, OZ, TN, T, GN, TROYOZ, TROYLB, LT, NONE
SEC.DECPNT	Secondary units decimal position	8.888888, 88.88888, 888.8888, 8888.888, 88888.88, 888888.8, 8888888, 8888880, 8888800
SEC.DSPDIV	Secondary units display divisions	1D, 2D, 5D
SEC.UNITS	Secondary units	LB, KG, G, OZ, TN, T, GN, TROYOZ, TROYLB, LT, NONE
SEC.MULT	Secondary units multiplier	0.00000-99999.99
DECfmt	Decimal format	DOT, COMMA
DSPrATE	Display rate	250MS, 500MS, 750MS, 1SEC, 1500MS, 2SEC, 2500MS, 3SEC, 4SEC, 6SEC, 8SEC

Table 5-4. FORMAT EDP Commands

Command	Description	Values
WZERO	Zero calibration	—
WVAL	Test weight value	<i>test_weight_value</i>
WSPAN	Span calibration	—
WLIN.F1-WLIN.F5	Actual raw count value for linearization points 1-5	—
WLIN.V1-WLIN.V5	Test weight value for linearization points 1-5	<i>test_weight_value</i>
REZERO	Rezero	—
LC.CD	Set deadload coefficient	<i>value</i>
LC.CW	Set span coefficient	<i>value</i>

Table 5-5. CALIBR EDP Commands

Command	Description	Values
EDP.BAUD	EDP port baud rate	300, 600, 1200, 2400, 4800, 9600, 19200
EDP.BITS	EDP port data bits/parity	8NONE, 7EVEN, 7ODD
EDP.TERMIN	EDP port termination character	CR/LF, CR
EDP.EOLDLY	EDP port end-of-line delay	0–255 (0.1-second intervals)
EDP.HANDSHK	EDP port handshaking	OFF, ON
EDP.ADDRESS	EDP port RS-485 address	0, 01–255
EDP.AB-RIO	EDP port Remote I/O stream	OFF, ON
EDP.STREAM	EDP port streaming	OFF, ON
PRN.BAUD	Printer port baud rate	300, 600, 1200, 2400, 4800, 9600, 19200
PRN.BITS	Printer port data bits/parity	8NONE, 7EVEN, 7ODD
PRN.TERMIN	Printer port termination character	CR/LF, CR
PRN.EOLDLY	Printer port end-of-line delay	0–255 (0.1-second intervals)
PRN.HANDSHK	Printer port handshaking	OFF, ON
PRN.STREAM	Printer port streaming	OFF, ON
PRNDEST	Print destination	EDP, PRN, BOTH

Table 5-6. SERIAL EDP Commands

Command	Description	Values
SD	Set date	MMDDYY or DDMMYY (enter using DATEFMT specified)
ST	Set time	hhmm (enter using 24-hour format)
DATEFMT	Date format	MMDDYY, DDMMYY
DATESEP	Date separator	SLASH, DASH, SEMI
TIMEFMT	Time format	12HOUR, 24HOUR
TIMESEP	Time separator	COLON, COMMA
CONSTUP	Consecutive number start-up value	0–999 999
KYBDLK	Keyboard lock (disable keypad)	OFF, ON
ZERONLY	Disable all keys except ZERO	OFF, ON
REGULAT	Regulatory compliance	NONE, OIML, NTEP, CANADA

Table 5-7. PROGRM EDP Commands

Command	Description	Values
GFMT	Gross demand print format string	See Section 6.0 on page 37 for detailed information
NFMT	Net demand print format string	
EDPFMT	EDP demand print format string	
HDRFMT	Header format string	

Table 5-8. PFORMT EDP Commands

Command	Description	Values
DIGIN1 DIGIN2 DIGIN3 DIGIN4 DIGIN5 DIGIN6 DIGIN7 DIGIN8	Digital input function	OFF, ZERO, NT/GRS, TARE, UNITS, PRINT, DSPTAR, KBDLOC, HOLD, CLRCN

Table 5-9. DIG IN EDP Commands

Command	Description	Values
SOURCE1	Analog output source	GROSS, NET
OFFSET	Zero offset	0%, 20%
ERRACT	Error action	FULLSC, HOLD, ZEROSC
MIN	Minimum value tracked	0-9 999 800
MAX	Maximum value tracked	0-9 999 800
ZERO1	Zero calibration	0-16 383
SPAN1	Span calibration	0-16 383

Table 5-10. ALGOUT EDP Commands

5.1.5 Normal Mode Commands

The normal mode commands (see Table 5-11) transmit data to the EDP port on demand. These commands are valid only in normal operating mode.

Command	Description	Response Format
CONSNUM	Set consecutive number	0-999 999
SD	Set date	MMDDYY or DDMMYY (enter using DATEFMT specified)
ST	Set time	hhmm (enter using 24-hour format)
SX	Start EDP streaming	OK or ??
EX	Stop EDP streaming	OK or ??
DX	Start streaming raw A/D counts	OK or ??
RS	Reset system	—
XG	Transmit gross weight in displayed units	nnnnnn UU
XN	Transmit net weight in displayed units	where nnnnnn is the weight value, UU is the units.
XT	Transmit tare weight in displayed units	
XG2	Transmit gross weight in non-displayed units	
XN2	Transmit net weight in non-displayed units	
XT2	Transmit tare weight in non-displayed units	
XE	Query system error conditions	nnnnn nnnnn See Section 7.1.2 on page 40 for detailed information about the XE command response format.

Table 5-11. Normal Mode EDP Commands

5.2 Saving and Transferring Data

Connecting a personal computer to the IQ plus 510 EDP port allows you to save indicator configuration data to the PC or to download configuration data from the PC to an indicator. The following sections describe the procedures for these save and transfer operations.

5.2.1 Saving Indicator Data to a Personal Computer

Configuration data can be saved to a personal computer connected to the EDP port. The PC must be running a communications program such as PROCOMMPLUS® or CROSSTALK®. See Section 2.3.2 on page 5 for information about serial communications wiring and EDP port pin assignments.

When configuring the indicator, ensure that the values set for the BAUD and BITS parameters on the SERIAL menu match the baud rate, bits, and parity settings configured for the serial port on the PC.

To save all configuration data, send the DUMPALL EDP command to the indicator. The IQ plus 510 responds by sending all configuration parameters to the PC as ASCII-formatted text.

5.2.2 Downloading Configuration Data from PC to Indicator

Configuration data saved on a PC or floppy disk can be downloaded from the PC to an indicator. This procedure is useful when a number of indicators with similar configurations are set up or when an indicator is replaced.

To download configuration data, connect the PC to the EDP port as described in Section 5.2.1. Place the indicator in setup mode and use the PC communications software to send the saved configuration data to the indicator. When transfer is complete, calibrate the indicator as described in Section 4.0 on page 28.

NOTE: Calibration settings are included in the configuration data downloaded to the indicator. If the receiving indicator is a direct replacement for another IQ plus 510 and the attached scale is not changed, recalibration is not required.

6.0 Print Formatting

The IQ plus 510 provides three print formats, GFMT, NFMT, and EDPFMT, that determine the format of the printed output when the PRINT key is pressed or when a KPRINT EDP command is received. Each print format can be customized to include up to 300 characters of information.

A fourth format, HDRFMT, allows specification of up to 300 characters of ticket header information for use on the GFMT, NFMT, and EDPFMT tickets. The contents of the HDRFMT format can be inserted into any other ticket format using the <AE> formatting command.

If the indicator is in gross mode, the GFMT print format is used; if in net mode, NFMT is used. If PRNDEST is set to BOTH (SERIAL menu), the GFMT print format is sent to the printer port, the EDPFMT print format to the EDP port.

You can use the indicator front panel (PFORMAT menu), EDP commands, or the Revolution™ Scaleware configuration utility to customize the print formats.

6.1 Print Formatting Commands

Table 6-1 lists commands you can use to format the gross and net print formats. Commands included in the format strings must be enclosed between < and > delimiters. Any characters outside of the delimiters are printed as text on the ticket. Text characters can include any ASCII character that can be printed by the output device.

Command	Description
<G>	Gross weight in displayed units
<G2>	Gross weight in non-displayed units
<N>	Net weight in displayed units
<N2>	Net weight in non-displayed units
<T>	Tare weight in displayed units
<T2>	Tare weight in non-displayed units
<AE>	Ticket header (HDRFMT)
<TI>	Time
<DA>	Date
<TD>	Time and date
<ID>	ID number
<CN>	Consecutive number
<NLnn>	New line (<i>nn</i> = number of termination (<CR/LF> or <CR>) characters)*
<SPnn>	Space (<i>nn</i> = number of spaces)*
<SU>	Toggle weight data format (formatted/unformatted)**
Gross, net, and tare weights are 9 digits in length, including sign (10 digits with decimal point), followed by a space and a two-digit units identifier. Total field length with units identifier is 12 (or 13) characters.	
ID and consecutive number (CN) fields are 1–7 characters in length, as required.	

Table 6-1. Print Format Commands

Command	Description
	Ticket header (AE) inserts information specified for the HDRFMT header format.
	* If <i>nn</i> is not specified, 1 is assumed. Value must be in the range 1–99.
	** After receiving an SU command, the indicator sends unformatted data until the next SU command is received. Unformatted data omits decimal points, leading and trailing characters.

Table 6-1. Print Format Commands (Continued)

The default print formats use only the new line (<NL>, <NL2>) and gross, net, and tare weight commands in displayed units (<G>, <N>, and <T>).

The default IQ plus 510 print formats are shown in Table 6-2.

Format	Default Format String
GFMT	GROSS<G><NL>
NFMT	GROSS<G><NL>TARE<SP><T><NL>NET<SP2><N><NL>
EDPFMT	GROSS<G><NL>
HDRFMT	COMPANY NAME<NL>STREET ADDRESS<NL>CITY, ST ZIP<NL2>

Table 6-2. Default Print Formats

NOTES:

- The <G2>, <N2>, and <T2> commands listed in Table 6-1 print the gross, net, and tare weights in non-displayed units—that is, in the units *not* currently displayed on the indicator.
- ID numbers included in the print format string (<ID> command) must be set using the KNEWID EDP command.

6.2 Customizing Print Formats

The following sections describe procedures for customizing the IQ plus 510 print formats using the EDP port, the front panel (PFORMAT menu), and the Revolution Scaleware configuration utility.

6.2.1 Using the EDP Port

With a personal computer, terminal, or remote keyboard attached to the IQ plus 510 EDP port, you can use the EDP command set to customize the print format strings.

To view the current setting of a format string, type the name of the string (HDRFMT, GFMT, NFMT, or EDPFMT) and press ENTER. For example, to check the current configuration of the GFMT format, type GFMT and press ENTER. The indicator responds by sending the current configuration for the gross format:

```
GFMT=<G> GROSS<NL>
```

To change the format, use the HDRFMT, GFMT, NFMT, or EDPFMT EDP command followed by an equals sign (=) and the modified print format string. For example, to add the name and address of a company to the gross format, you could send the following EDP command:

```
GFMT=MOE'S DUMP<NL>2356 EAST HIGHWAY  
ROAD<NL>SMALLTOWN<NL2><G> GROSS<NL>
```

A ticket printed using this format might look like the following:

```
MOE'S DUMP  
2356 EAST HIGHWAY ROAD  
SMALLTOWN
```

```
1345 LB GROSS
```

The ticket above could also be formatted by specifying the company address information in the HDRFMT ticket format, then substituting the <AE> command for the address in the GFMT ticket format:

```
HDRFMT=MOE'S DUMP<NL>2356 EAST HIGHWAY  
ROAD<NL>SMALLTOWN<NL2>
```

```
GFMT=<AE><G> GROSS<NL>
```

6.2.2 Using the Front Panel

If you have no access to equipment for communication through the EDP port or are working at a site where such equipment cannot be used, you can use the PFORMAT menu (see Figure 6-1) to customize the print formats.

Using the PFORMAT menu, you can edit the print format strings by changing the decimal values of the ASCII characters in the format string.

NOTE: Lower-case letters and some special characters cannot be displayed on the IQ plus 510 front panel (see the ASCII character chart on page 43) and are shown as blanks. The IQ plus 510 can send or receive any ASCII character; the character printed depends on the particular ASCII character set implemented for the receiving device.

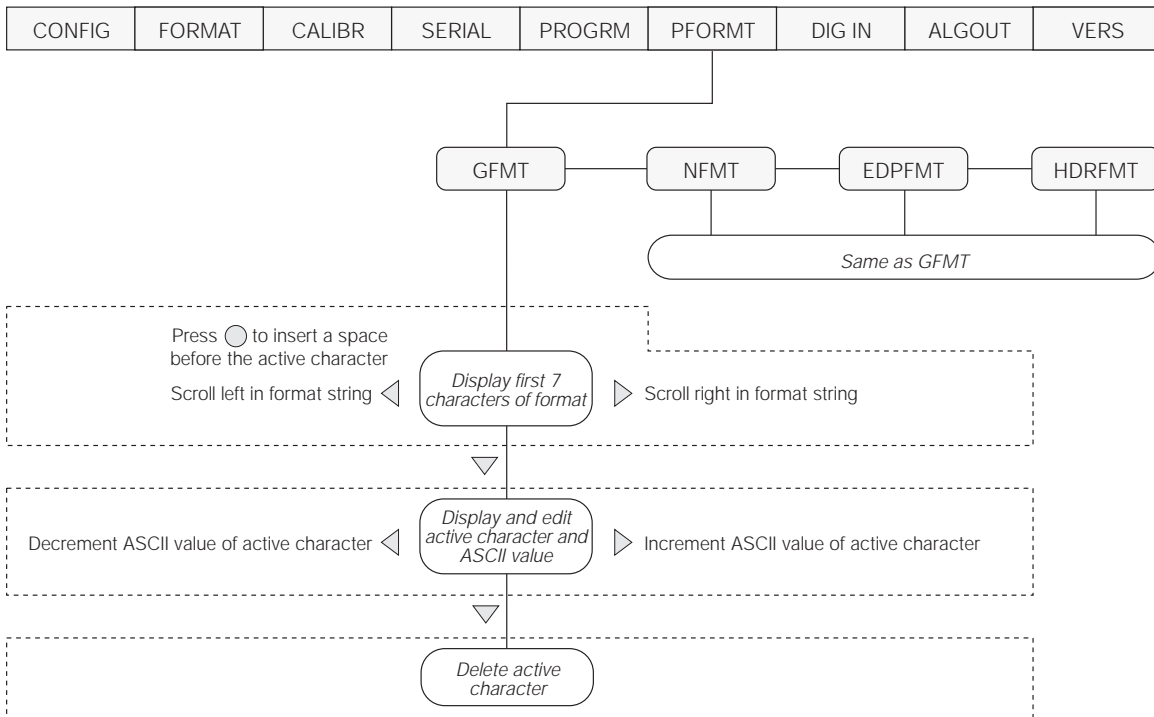

Figure 6-1. PFORMAT Menu, Showing Alphanumeric Character Entry Procedure

6.2.3 Using Revolution™ Scaleware

The Revolution Scaleware configuration utility provides a print formatting grid with a tool bar. The grid allows you to construct the print format without the formatting commands (<NL> and <SP>) required by the front panel or EDP command methods. Using Revolution, you can type text directly into the grid, then select weight value fields from the tool bar and place them where you want them to appear on the printed ticket.

Figure 6-2 shows an example of the Revolution Scaleware print formatting grid.

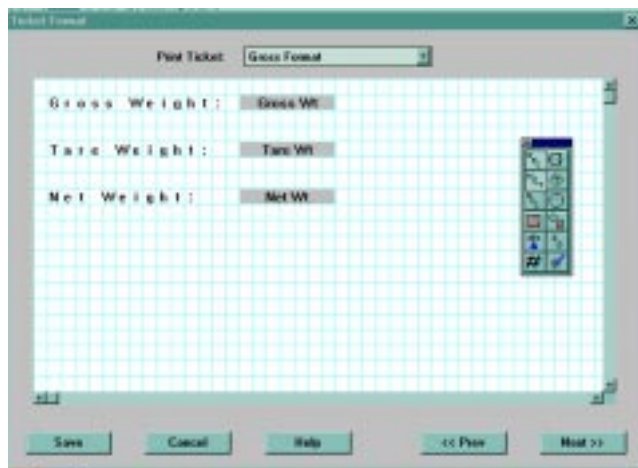

Figure 6-2. Revolution Scaleware Print Format Grid

7.0 Appendix

7.1 Error Messages

The IQ plus 510 indicator provides a number of error messages. When an error occurs, the message is shown on the indicator display. Error conditions can also be checked remotely by using the XE EDP command as described in Section 7.1.2.

7.1.1 Displayed Error Messages

The IQ plus 510 provides a number of front panel error messages to assist in problem diagnosis. Table 7-1 lists these messages and their meanings.

Error Message	Description	Solution
E A/D	A/D physical error	Call Rice Lake Weighing Systems (RLWS) Service.
E EEROM	EEPROM physical error	
E VIREE	Virgin EEPROM	Use TEST menu to perform DEFLT (restore defaults) procedure, then recalibrate load cells.
E PCKSM	Parameter checksum error	
E LCKSM	Load cell calibration checksum error	Recalibrate load cells.
E ACKSM	A/D calibration checksum error	A/D converter requires recalibration. Call RLWS Service.
E IDATA	Internal RAM test error	Call RLWS Service.
E XDATA	External RAM test error	
E REF	A/D reference error	A/D converter requires recalibration. Call RLWS Service.
OVERFL	Overflow error	Weight value too large to be displayed.
REG ERR	Battery fault	Battery weak or not installed. Replace battery then use TEST menu to perform CLR NV (clear non-volatile storage) procedure.
-----	Gross > overload limit	Gross value exceeds overload limit. Check configuration.
_____	A/D underrange	A/D reading < -4 mV. Check scale for binding or damage.

Table 7-1. IQ plus 510 Error Messages

7.1.2 Using the XE EDP Command

The XE EDP command can be used to remotely query the IQ plus 510 for the error conditions shown on the front panel. The XE command returns two 5-digit numbers in the format:

xxxxx yyyy

where xxxxx contains a decimal representation of any existing error conditions as described in Table 7-2.

If more than one error condition exists, the number returned is the sum of the values representing the error conditions. For example, if the XE command returns the number 288, this value represents the sum of an A/D reference error (256) and an A/D calibration checksum error (32).

The second number returned (yyyyy) uses the same bit assignments as shown in Table 7-2 on page 41 to indicate whether the test for the error condition was run. For example, the value yyyyy = 50687 represents the decimal equivalent of the binary value 1100 0101 1111 1111. Using the bit assignments in Table 7-2, this indicates all tests were run except the NV register checksum test.

Error Code	Description	Binary Value
0	No error	0000 0000 0000 0000
1	A/D physical error	0000 0000 0000 0001
2	EEPROM physical error	0000 0000 0000 0010
4	Virgin EEPROM	0000 0000 0000 0100
8	Parameter checksum error	0000 0000 0000 1000
16	Load cell calibration checksum error	0000 0000 0001 0000
32	A/D calibration checksum error	0000 0000 0010 0000
64	Internal RAM data error	0000 0000 0100 0000
128	External RAM data error	0000 0000 1000 0000
256	A/D reference error	0000 0001 0000 0000
512	NV register checksum error	0000 0010 0000 0000
1024	Printer format checksum error	0000 0100 0000 0000
2048	<i>not assigned</i>	0000 1000 0000 0000
4096	<i>not assigned</i>	0001 0000 0000 0000
8192	<i>not assigned</i>	0010 0000 0000 0000
16384	A/D underrange	0100 0000 0000 0000
32768	Gross > overload limit	1000 0000 0000 0000

Table 7-2. Error Codes Returned on XE Command

7.2 Status Messages

Two EDP commands, P and ZZ, can be used to provide status about the indicator.

- The P EDP command returns whatever is currently shown in the indicator's primary display area.
- The ZZ EDP command returns whatever is currently shown in both the primary and secondary displays. Depending on the type of device used to receive data from the indicator, the standstill and center of zero symbols may be shown as spaces or as special characters. The ZZ command returns information in the following format:

PPPPPPP uu sssssssssssssss

where:

- *PPPPPPP* is the information shown on the primary display
- *uu* is the 2-digit units annunciator
- *ssssssssssssss* is the contents of the secondary display

If the indicator is in an underrange or overload condition, the weight value is replaced with &&&&& (overload) or : : : : (underrange).

7.3 Data Formats

7.3.1 Continuous Output Serial Data Format

If continuous transmission is configured for the EDP or printer port (STREAM parameter on the SERIAL menu), the IQ plus 510 sends data using the Consolidated Controls serial data format shown in Figure 7-1:

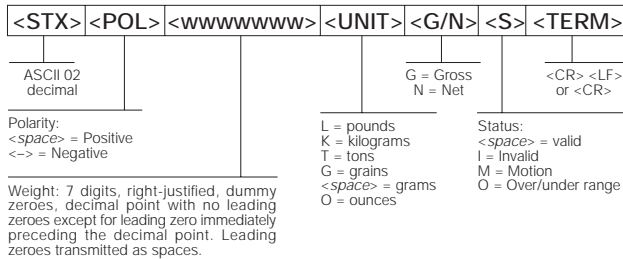

Figure 7-1. Continuous Output Serial Data Format

7.3.2 Demand Output Serial Data Format

When demand mode is configured for the EDP or printer port in the setup menus (PRNDEST on the SERIAL menu), the IQ plus 510 uses a data string formatted for a basic ticket printout. The particular ticket format printed depends on the indicator configuration.

You can use the EDP port or keypad to fully customize the ticket to work with a wide variety of printers, scoreboard displays, and other remote equipment. See Section 6.0 on page 37 for more information on custom print formats.

7.3.3 RS-485 Data Formats

The IQ plus 510 has a built-in RS-485 software protocol which is enabled when you assign a non-zero address to the indicator. Valid RS-485 addresses must be in the range 1–255; the address is specified on the ADDRESS parameter on the SERIAL menu.

All remote commands are initiated using the data format shown in Figure 7-2:

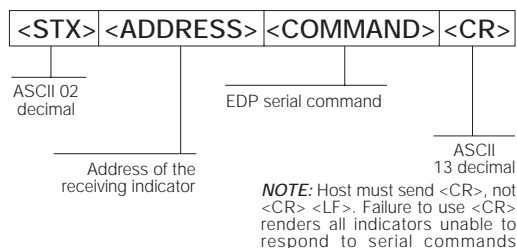

Figure 7-2. RS-485 Send Data Format

If the initiating device address matches the port address of an IQ plus 510 on the RS-485 network, that indicator responds. For example, with demand outputs, or in response to a KPRINT command, the responding indicator uses the format shown in Figure 7-3:

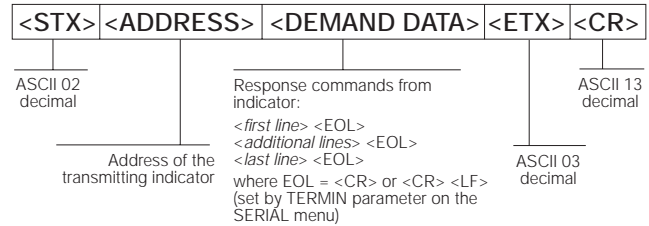

Figure 7-3. RS-485 Respond Data Format

Example: To send the KPRINT command from an ASCII terminal to an indicator at address 65 (decimal) on the RS-485 network, use the format shown in Figure 7-2.

- The keyboard equivalent for the start-of-text (STX) character is CONTROL-B (see Table 7-3 on page 43).
- The indicator address (65) is represented by an upper case “A”.
- The carriage return (CR) character is generated by pressing the ENTER key.

Therefore, to send the KPRINT command to the indicator at address 65, enter the following at the terminal: CONTROL-B, A, K, P, R, I, N, T, ENTER.

The indicator responds with the format shown in Figure 7-3:

```
<STX> A SCALE #1 <EOL>
      GROSS 1699 LB<EOL>
      08/20/1998 10:05 AM<EOL>
<ETX> <CR>
```

If continuous transmission is configured for the EDP port (STREAM parameter on the SERIAL menu), the IQ plus 510 sends data using the data format shown in Figure 7-4:

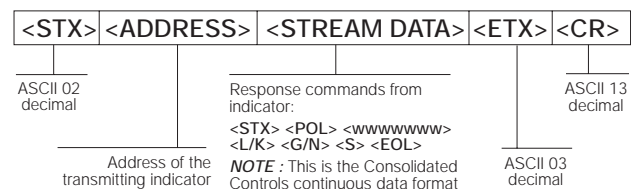

Figure 7-4. RS-485 Continuous Data Format

7.4 ASCII Character Chart

Use the decimal values for ASCII characters listed in Tables 7-3 and 7-4 when specifying print format strings on the IQ plus 510 PFORMAT menu. The actual character printed depends on the character mapping used by the output device.

The IQ plus 510 can send or receive any ASCII character value (decimal 0–255). Due to limitations of the indicator display, some characters cannot be shown.

Control	ASCII	Dec	Hex	ASCII	Dec	Hex	ASCII	Dec	Hex	ASCII	Dec	Hex
Ctrl-@	NUL	00	00	space	32	20	@	64	40	`	96	60
Ctrl-A	SOH	01	01	!	33	21	A	65	41	a	97	61
Ctrl-B	STX	02	02	“	34	22	B	66	42	b	98	62
Ctrl-C	ETX	03	03	#	35	23	C	67	43	c	99	63
Ctrl-D	EOT	04	04	\$	36	24	D	68	44	d	100	64
Ctrl-E	ENQ	05	05	%	37	25	E	69	45	e	101	65
Ctrl-F	ACK	06	06	&	38	26	F	70	46	f	102	66
Ctrl-G	BEL	07	07	’	39	27	G	71	47	g	103	67
Ctrl-H	BS	08	08	(40	28	H	72	48	h	104	68
Ctrl-I	HT	09	09)	41	29	I	73	49	i	105	69
Ctrl-J	LF	10	0A	*	42	2A	J	74	4A	j	106	6A
Ctrl-K	VT	11	0B	+	43	2B	K	75	4B	k	107	6B
Ctrl-L	FF	12	0C	,	44	2C	L	76	4C	l	108	6C
Ctrl-M	CR	13	0D	-	45	2D	M	77	4D	m	109	6D
Ctrl-N	SO	14	0E	.	46	2E	N	78	4E	n	110	6E
Ctrl-O	SI	15	0F	/	47	2F	O	79	4F	o	111	6F
Ctrl-P	DLE	16	10	0	48	30	P	80	50	p	112	70
Ctrl-Q	DC1	17	11	1	49	31	Q	81	51	q	113	71
Ctrl-R	DC2	18	12	2	50	32	R	82	52	r	114	72
Ctrl-S	DC3	19	13	3	51	33	S	83	53	s	115	73
Ctrl-T	DC4	20	14	4	52	34	T	84	54	t	116	74
Ctrl-U	NAK	21	15	5	53	35	U	85	55	u	117	75
Ctrl-V	SYN	22	16	6	54	36	V	86	56	v	118	76
Ctrl-W	ETB	23	17	7	55	37	W	87	57	w	119	77
Ctrl-X	CAN	24	18	8	56	38	X	88	58	x	120	78
Ctrl-Y	EM	25	19	9	57	39	Y	89	59	y	121	79
Ctrl-Z	SUB	26	1A	:	58	3A	Z	90	5A	z	122	7A
Ctrl-[ESC	27	1B	;	59	3B	[91	5B	{	123	7B
Ctrl-\	FS	28	1C	<	60	3C	\	92	5C		124	7C
Ctrl-]	GS	29	1D	=	61	3D]	93	5D	}	125	7D
Ctrl-^	RS	30	1E	>	62	3E	^	94	5E	~	126	7E
Ctrl- <u>_</u>	US	31	1F	?	63	3F	_	95	5F	DEL	127	7F

Table 7-3. ASCII Character Chart (Part 1)

ASCII	Dec	Hex	ASCII	Dec	Hex	ASCII	Dec	Hex	ASCII	Dec	Hex
Ç	128	80	á	160	A0		192	C0	α	224	E0
ü	129	81	í	161	A1		193	C1	β	225	E1
é	130	82	ó	162	A2		194	C2	Γ	226	E2
â	131	83	ú	163	A3		195	C3	π	227	E3
ä	132	84	ñ	164	A4		196	C4	Σ	228	E4
à	133	85	Ñ	165	A5		197	C5	σ	229	E5
å	134	86	ª	166	A6		198	C6	μ	230	E6
ç	135	87	º	167	A7		199	C7	τ	231	E7
ê	136	88	¿	168	A8		200	C8	Φ	232	E8
ë	137	89		169	A9		201	C9	Θ	233	E9
è	138	8A	¬	170	AA		202	CA	Ω	234	EA
ï	139	8B	½	171	AB		203	CB	δ	235	EB
î	140	8C	¼	172	AC		204	CC	∞	236	EC
ì	141	8D	¡	173	AD		205	CD	φ	237	ED
Ä	142	8E	«	174	AE		206	CE	∈	238	EE
Å	143	8F	»	175	AF		207	CF	∩	239	EF
É	144	90		176	B0		208	D0	=	240	F0
æ	145	91		177	B1		209	D1	±	241	F1
Æ	146	92		178	B2		210	D2	≥	242	F2
ô	147	93		179	B3		211	D3	≤	243	F3
ö	148	94		180	B4		212	D4	∫	244	F4
ò	149	95		181	B5		213	D5	∫	245	F5
û	150	96		182	B6		214	D6	÷	246	F6
ù	151	97		183	B7		215	D7	≈	247	F7
ÿ	152	98		184	B8		216	D8	°	248	F8
Ö	153	99		185	B9		217	D9	•	249	F9
Ü	154	9A		186	BA		218	DA		250	FA
ç	155	9B		187	BB		219	DB		251	FB
£	156	9C		188	BC		220	DC		252	FC
¥	157	9D		189	BD		221	DD	²	253	FD
Pts	158	9E		190	BE		222	DE		254	FE
f	159	9F		191	BF		223	DF		255	FF

Table 7-4. ASCII Character Chart (Part 2)

7.5 Digital Filtering

Standard digital filtering uses mathematical averaging to eliminate the variant digital readings that the A/D converter sends periodically because of external vibration. Digital filtering does not affect the indicator measurement rate, but does affect the settling time. The selections from 1 to 256 reflect the number of readings averaged per update period. When a reading is encountered that is outside a predetermined band, the averaging is overridden, and the display jumps directly to the new value.

RATTLETRAP® digital filtering (DIGFLTR values followed by the letters RT) uses a vibration-dampening algorithm to provide a combination of the best features of analog and digital filtering. The RATTLETRAP algorithm evaluates the frequency of a repeating vibration then derives a composite displayed weight equal to the actual weight on the scale less the vibration-induced flaws. It is particularly effective for eliminating vibration effects or mechanical interference from nearby machinery. RT selections eliminate much more mechanical vibration than standard digital filtering, but usually also increase settling time over standard digital filtering.

7.5.1 DFSENS and DFTHR parameters

The digital filter can be used by itself to eliminate vibration effects, but heavy filtering also increases settling time. The DFSENS (digital filter sensitivity) and DFTHR (digital filter threshold) parameters can be used to temporarily override filter averaging and improve settling time:

- DFSENS specifies the number of consecutive scale readings that must fall outside the filter threshold (DFTHR) before digital filtering is suspended.
- DFTHR sets a threshold value, in display divisions. When a specified number of consecutive scale readings (DFSENS) fall outside of this threshold, digital filtering is suspended.

7.6 Conversion Factors for Secondary Units

The IQ plus 510 has the capability to mathematically convert a weight into many different types of units and instantly display those results with a press of the UNITS key.

Secondary units can be specified on the FORMAT menu using the SECNDR parameter, or by using EDP commands.

- To configure secondary units using the front panel menus, use the Table 7-5 to find the

7.5.2 Setting the Digital Filter Parameters

Fine-tuning the digital filter parameters greatly improves indicator performance in heavy-vibration environments. Use the following procedure to determine vibration effects on the scale and optimize the digital filtering configuration.

1. In setup mode, set the digital filter (DIGFLTR parameter) to 1. Set DFTHR to NONE. Return indicator to normal mode.
2. Remove all weight from the scale, then watch the indicator display to determine the magnitude of vibration effects on the scale. Record the weight below which all but a few readings fall. This value is used to calculate the DFTHR parameter value in Step 4.

For example, if a heavy-capacity scale produces vibration-related readings of up to 50 lb, with occasional spikes to 75 lb, record 50 lb as the threshold weight value.

3. Place the indicator in setup mode and set the DIGFLTR parameter to eliminate the vibration effects on the scale. (Leave DFTHR set to NONE.) Find the lowest effective value for the DIGFLTR parameter.
4. Calculate the DFTHR parameter value by converting the weight value recorded in Step 2 to display divisions:

$$\text{threshold_weight_value} / \text{DSPDIV}$$

In the example in Step 2, with a threshold weight value of 50 lb and a display division value of 5D: $50 / 5D = 10$. DFTHR should be set to 10DD for this example.

5. Finally, set the DFSENS parameter high enough to ignore transient peaks. Longer transients (typically caused by lower vibration frequencies) will cause more consecutive out-of-band readings, so DFSENS should be set higher to counter low frequency transients.

Reconfigure as necessary to find the lowest effective value for the DFSENS parameter.

conversion multiplier for the MULT parameter. For example, if the primary unit is pounds and the secondary unit is short tons, set the MULT parameter to 0.000500.

For secondary units with a conversion factor of 10 or more, you must use the MULEXP parameter to move the decimal point. For example, if the primary unit is ounces and the secondary unit is grams, the conversion factor shown in Table 7-5 is 28.3495. To enter this

value using the menus, first enter 2.83495 for the MULT parameter, then use the MULEXP parameter to adjust the decimal point to 28.3495.

- To configure secondary units using EDP commands, use the Table 7-5 to find the conversion multiplier for the SEC.MULT command. For example, if the primary unit is pounds and the secondary unit is short tons, send the EDP command SEC.MULT=0.0005<CR> to set the multiplier for the secondary units.

NOTE: Ensure that the secondary decimal point position is set appropriately for the scale capacity in the secondary units. If the converted value requires more digits than are available, the indicator will display an overflow message (*OVERFL*).

For example, if the primary units are short tons, secondary units are pounds, and the secondary decimal point is set to 8888.888, the indicator will overflow if 5 tons or more are applied to the scale. With 5 tons applied, and a conversion factor of 2000, the secondary units display needs five digits to the left of the decimal point to display the 10000 lb secondary units value.

Primary Unit	<i>x Multiplier</i>	Secondary Unit
grains	0.064799	grams
	0.002286	ounces
	0.000143	pounds
	0.000065	kilograms
	0.002083	troy ounces
	0.000174	troy pounds
ounces	437.500	grains
	28.3495	grams
	0.06250	pounds
	0.02835	kilograms
	0.911458	troy ounces
	0.075955	troy pounds
pounds	7000.00	grains
	453.592	grams
	16.0000	ounces
	0.453592	kilograms
	14.58333	troy ounces
	1.215278	troy pounds
	0.000500	short tons
	0.000446	long tons
	0.000453	metric tons

Table 7-5. Conversion Factors

Primary Unit	<i>x Multiplier</i>	Secondary Unit
grams	15.4324	grains
	0.035274	ounces
	0.002205	pounds
	0.001000	kilograms
	0.032151	troy ounces
	0.002679	troy pounds
kilograms	15432.4	grains
	35.2740	ounces
	1000.00	grams
	2.20462	pounds
	32.15075	troy ounces
	2.679229	troy pounds
	0.001102	short tons
	0.000984	long tons
	0.001000	metric tons
	short tons	2000.00
907.185		kilograms
0.892857		long tons
0.907185		metric tons
metric tons	2204.62	pounds
	1000.00	kilograms
	1.10231	short tons
	0.984207	long tons
long tons	2240.00	pounds
	1016.05	kilograms
	1.12000	short tons
	1.01605	metric tons
troy ounces	480	grains
	31.10348	grams
	0.031103	kilograms
	1.09714	ounces
	0.068571	pounds
	0.083333	troy pounds
troy pounds	5760	grains
	373.2417	grams
	0.373242	kilograms
	13.16571	ounces
	0.822857	pounds
	12	troy ounces

Table 7-5. Conversion Factors (Continued)

7.7 Analog Output Calibration

The following calibration procedure requires a multimeter to measure voltage or current output from the analog output module. If the option is not already installed, see Section 2.4 on page 5.

NOTE: The analog output must be calibrated *after* the indicator itself has been configured (Section 3.0) and calibrated (Section 4.0).

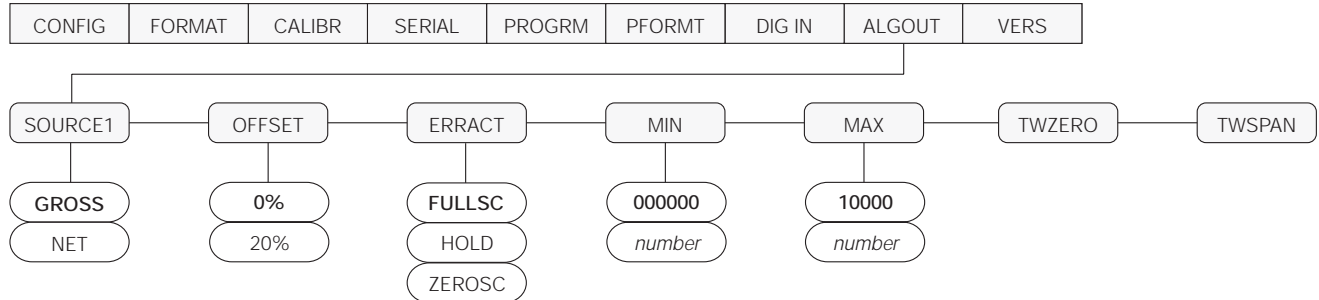

Figure 7-5. Analog Output Menu

1. Enter setup mode and go to the ALGOUT menu (see Figure 7-5):
 - Set OFFSET to 0% for 0–10 V output, 20% for 4–20 mA output
 - Set MIN to lowest weight value to be tracked by the analog output
 - Set MAX to highest weight value to be tracked by the analog output
2. Connect multimeter to connector J1 on the analog output board:
 - For voltage output, connect voltmeter leads to pins 3 and 4
 - For current output, connect ammeter leads to pins 1 and 2
3. Adjust zero calibration: Scroll to the TWZERO parameter. Check voltage or current reading on multimeter. Press and hold Δ or ∇ to adjust the zero value up or down.
4. Adjust span calibration: Scroll to the TWSPAN parameter. Check voltage or current reading on multimeter. Press and hold Δ or ∇ to adjust the span value up or down.
5. Final zero calibration: Return to the TWZERO parameter and verify that the zero calibration has not drifted. Press and hold Δ or ∇ to re-adjust the zero value as required.
6. Return to normal mode. Analog output function can be verified using test weights.

7.8 Test Mode

In addition to normal and setup modes, test mode provides a number of diagnostic functions for the IQ plus 510, including:

- Display raw A/D count
- Display digital input states
- Reset configuration parameters to default values
- Clear non-volatile (battery backed) storage
- Transmit test character (“U”) from serial port
- Display characters received by serial port
- Set analog output state to zero or full scale
- Set A/D offset and gain calibration

To enter test mode, press and hold the setup switch until the front panel display shows the word *TEST*. After about three seconds, the test mode display automatically shifts to the first test menu function, A/DTST.



Caution

A/D calibration functions, ADOFFS and ADGAIN, must be used only by qualified service personnel, and only after replacing A/D converter components. Improper A/D calibration may render the indicator unusable.

Figure 7-6 shows the Test Menu structure; Figure 7-7 shows the front panel key functions in test mode. Note that, because the Test Menu functions are all on a single menu level, the GROSS/NET (▽) key has no function. Press the ZERO (△) key to exit test mode.

Table 7-6 on page 49 summarizes the test menu functions.

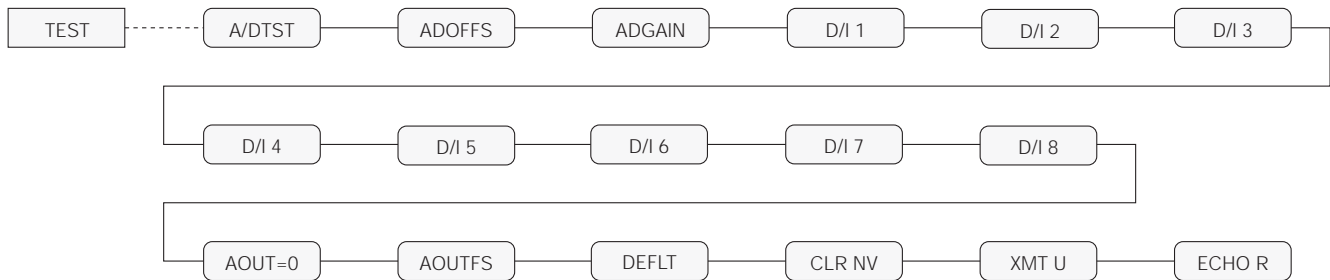

Figure 7-6. Test Menu

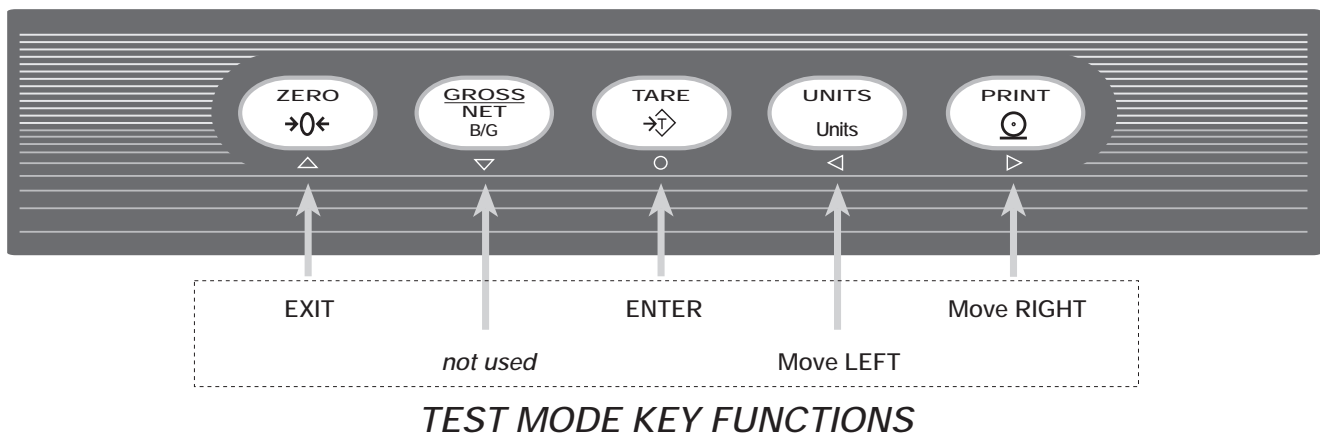

Figure 7-7. Front Panel Key Functions in Test Mode

TEST Menu	
Function	Description
A/DTST	Display A/D test Press and hold Enter key to display raw count from A/D converter.
ADOFFS	A/D offset calibration (-0.5 mv/V) Read Caution! statement on page 48 before using this function. Press and hold the setup switch, then press the Enter key to perform offset calibration.
ADGAIN	A/D gain calibration (+4.5 mv/V) Read Caution! statement on page 48 before using this function. Press and hold the setup switch, then press the Enter key to perform gain calibration.
D/I 1 — D/I 8	Display digital inputs 1–8 Press and hold Enter key to show status of DIGINx (Dix=HI or Dix=LO).
AOUT=0	Set analog output to zero Press and hold Enter key to set analog output to its zero value.
AOUTFS	Set analog output to full scale Press and hold Enter key to set analog output to its full scale value.
DEFLT	Default parameters Press and hold the setup switch, then press the Enter key to reset configuration and calibration parameters to factory default values. Load cells must be recalibrated before using the indicator (see Section 4.0 on page 28);
CLR NV	Clear non-volatile storage Press and hold the setup switch, then press the Enter key to clear values stored in battery-backed SRAM.
XMT U	Transmit "U" Press and hold Enter key to send ASCII "U" characters (decimal 85) from the serial port.
ECHO R	Echo received characters Press and hold Enter key to view characters received at serial port. NOTE: IQ plus 510 display shows lower-case characters as blanks.

Table 7-6. Test Menu Functions

7.9 Software Upgrade Instructions

Use the following procedure to replace the IQ plus 510 EPROM:

1. Disconnect indicator from power source.
2. Place indicator face-down on an antistatic work mat. Remove screws that hold the backplate to the enclosure body.

 **Warning** *Disconnect power before removing indicator backplate.*

3. Loosen all in-use cord grips then lift the backplate away from the enclosure and set it aside.

 **Caution** *Use a wrist strap to ground yourself and protect components from electrostatic discharge (ESD) when working inside the indicator enclosure.*

4. For units using the Rev. 1 CPU board with cable interface board, remove the four screws that secure the interface board to its mounting brackets. The interface board must be moved to access the EPROM in the following step.
5. Locate the EPROM (see Figure 2-1 on page 4). Carefully remove old EPROM from socket.
6. Remove new EPROM from packaging and place on top of empty socket. Ensure EPROM is correctly oriented (notch toward center of CPU board) and all pins are aligned with socket. Press down firmly to seat new EPROM in the socket.
7. For units using the Rev. 1 CPU board with cable interface board, reinstall board using screws removed in Step 4.

8. Position backplate over the enclosure and reinstall the backplate screws. Use the torque pattern shown in Figure 2-2 on page 6 to prevent distorting the backplate gasket. Torque backplate screws to 10 in-lb (1.13 N-m).
9. Ensure no excess cable is left inside the enclosure and tighten cord grips.
10. Reconnect power to the indicator.
11. Remove the setup switch access screw on the indicator backplate then set the indicator upright.
12. Press and hold the setup switch until the front panel display shows the word *TEST*. Two test mode procedures must be performed before using the new EPROM:
 - Clear non-volatile RAM (CLR NV)
 - Restore defaults (DEFLT)Use the navigation keys (press ◀ or ▶ to scroll left or right) to go to the *CLR NV* and *DEFLT* menu items (see Figure 7-6 on page 48).
 - With *CLR NV* shown on the display, press ○ (ENTER) and the setup switch at the same time to clear non-volatile RAM.
 - With *DEFLT* shown on the display, press ○ and the setup switch at the same time to restore defaults. Press ▲ to exit test mode.
13. Recalibrate and reconfigure the indicator.

7.10 Software Revision History

The following list summarizes the principal software changes made for Version 1.4:

Front Panel Time and Date Setting Enabled

The DATESET and TIMESET parameters on the PROGRAM menu allow time and date to be set from the front panel when the indicator is in setup mode. See Section 3.2.5 on page 24.

Enhanced Display Resolution

Up to 100 000 grads can be specified on the GRADS parameter (CONFIG menu) and on the GRADS EDP command.

HDRFMT Ticket Header Print Format Added

Contents of the HDRFMT format can be inserted into any other ticket format using the <AE> formatting command. See Section 6.0 on page 37 for details.

Improved Digital Filtering

Digital filter sensitivity (DFSSENS) and threshold (DFTHRH) parameters on the CONFIG menu provide improved digital filtering capability for the IQ plus 510. These values can also be configured using the DFSSENS and DFTHRH EDP commands. See Section 7.5 on page 45 for detailed information about using these parameters.

7.11 Specifications

Power

Line Voltages	115 or 230 VAC
Frequency	50 or 60 Hz
Power Consumption	100 mA @ 115 VAC (11.5 W) 50 mA @ 230 VAC (11.5 W)

Fusing

115 VAC	2 x 160 mA TR5 subminiature fuses Wickmann Time-Lag 19374 Series UL Listed, CSA Certified and Approved
230 VAC	2 x 80 mA TR5 subminiature fuses Wickmann Time-Lag 19372 Series UL Recognized, Semko and VDE Approved

Analog Specifications

Full Scale Input Signal	Up to 45 mV
Excitation Voltage	10 ± 0.5 VDC, 8 x 350Ω or 16 x 700Ω load cells
Sense Amplifier	Differential amplifier with 4- and 6-wire sensing
Analog Signal Input Range	0.6 mV/V – 4.5 mV/V
Analog Signal Sensitivity	0.3 μV/graduation minimum, 1.5 μV/grad recommended
Input Impedance	200 MΩ, typical
Noise (ref to input)	0.3 μV p-p with digital filter at 4
Internal Resolution	1 000 000 counts, approximate
Display Resolution	100 000 dd
Measurement Rate	60 measurements/sec, nominal
Input Sensitivity	50 nV per internal count
System Linearity	Within 0.01% of full scale
Zero Stability	150 nV/°C, maximum
Span Stability	3.5 ppm/°C, maximum
Calibration Method	Software, constants stored in EEPROM
Common Mode Voltage	± 4 V, referred to earth
Common Mode Rejection	140 dB minimum @ 50 or 60 Hz
Normal Mode Rejection	90 dB minimum @ 50 or 60 Hz
Input Overload	± 12 V continuous, static discharge protected
RFI Protection	Signal, excitation, and sense lines protected by capacitor bypass
Analog Output	Optional: fully isolated, voltage or current output, 14-bit resolution. Voltage output: 0 –10 VDC Load resistance: 1kΩ minimum Current output: 4–20 mA External loop resistance: 500Ω maximum

Digital Specifications

Microcomputer	Hitachi H8/3002 main processor @ 9.8304 MHz
Digital Inputs	8 inputs, TTL or switch closure, active-low
Digital Filter	Software selectable: 1–256, enhanced Rattletrap® hybrid digital filtering

Serial Communications

EDP Port	Full duplex RS-232 or RS-485
Printer Port	RS-232 or active 20 mA current loop
Both Ports	19 200, 9600, 4800, 2400, 1200, 600, 300 bps; 7 or 8 data bits; even, odd, or no parity; two stop bits on transmit, one stop bit on receive

Operator Interface

Display	Vacuum fluorescent display: 7-digit, 14-segment primary weight display; Two 5x7 dot matrix digits for units, alpha/ numeric entry mode designators; 16-digit dot matrix display for additional symbols, user prompts.
Keyboard	5-key membrane panel

Environmental

Operating Temperature	–10 to +40°C (legal); –10 to +50°C (industrial)
Storage Temperature	–25 to +70°C
Humidity	0–95% relative humidity
Altitude	2000 m (6500 ft) maximum

Enclosure

Enclosure Dimensions (without tilt stand)	
Sloped Enclosure:	9.5 in x 8.38 in x 4.95 in 241 mm x 213 mm x 126 mm
Flat Enclosure:	9.5 in x 8.38 in x 5.25 in 241 mm x 213 mm x 133 mm
Weight	
Sloped Enclosure:	7.4 lb (3.3 Kg)
Flat Enclosure:	7.8 lb (3.5 Kg)
Rating/Material	NEMA 4X/IP66, stainless steel

Certifications and Approvals



NTEP

CoC Number	98-081
Accuracy Class	III/III L n_{max} : 10 000



Measurement Canada

Approval	AM-5253
Accuracy Class	III n_{max} : 10 000 III HD n_{max} : 20 000

IQ plus 510 Limited Warranty

Rice Lake Weighing Systems (RLWS) warrants that all RLWS equipment and systems properly installed by a Distributor or Original Equipment Manufacturer (OEM) will operate per written specifications as confirmed by the Distributor/OEM and accepted by RLWS. All systems and components are warranted against defects in materials and workmanship for two years.

RLWS warrants that the equipment sold hereunder will conform to the current written specifications authorized by RLWS. RLWS warrants the equipment against faulty workmanship and defective materials. If any equipment fails to conform to these warranties, RLWS will, at its option, repair or replace such goods returned within the warranty period subject to the following conditions:

- Upon discovery by Buyer of such nonconformity, RLWS will be given prompt written notice with a detailed explanation of the alleged deficiencies.
- Individual electronic components returned to RLWS for warranty purposes must be packaged to prevent electrostatic discharge (ESD) damage in shipment. Packaging requirements are listed in a publication, *Protecting Your Components From Static Damage in Shipment*, available from RLWS Equipment Return Department.
- Examination of such equipment by RLWS confirms that the nonconformity actually exists, and was not caused by accident, misuse, neglect, alteration, improper installation, improper repair or improper testing; RLWS shall be the sole judge of all alleged non-conformities.
- Such equipment has not been modified, altered, or changed by any person other than RLWS or its duly authorized repair agents.
- RLWS will have a reasonable time to repair or replace the defective equipment. Buyer is responsible for shipping charges both ways.
- In no event will RLWS be responsible for travel time or on-location repairs, including assembly or disassembly of equipment, nor will RLWS be liable for the cost of any repairs made by others.

THESE WARRANTIES EXCLUDE ALL OTHER WARRANTIES, EXPRESSED OR IMPLIED, INCLUDING WITHOUT LIMITATION WARRANTIES OF MERCHANTABILITY OR FITNESS FOR A PARTICULAR PURPOSE. NEITHER RLWS NOR DISTRIBUTOR WILL, IN ANY EVENT, BE LIABLE FOR INCIDENTAL OR CONSEQUENTIAL DAMAGES.

RLWS AND BUYER AGREE THAT RLWS'S SOLE AND EXCLUSIVE LIABILITY HEREUNDER IS LIMITED TO REPAIR OR REPLACEMENT OF SUCH GOODS. IN ACCEPTING THIS WARRANTY, THE BUYER WAIVES ANY AND ALL OTHER CLAIMS TO WARRANTY.

SHOULD THE SELLER BE OTHER THAN RLWS, THE BUYER AGREES TO LOOK ONLY TO THE SELLER FOR WARRANTY CLAIMS.

NO TERMS, CONDITIONS, UNDERSTANDING, OR AGREEMENTS PURPORTING TO MODIFY THE TERMS OF THIS WARRANTY SHALL HAVE ANY LEGAL EFFECT UNLESS MADE IN WRITING AND SIGNED BY A CORPORATE OFFICER OF RLWS AND THE BUYER.

© 1999 Rice Lake Weighing Systems, Inc. Rice Lake, WI USA. All Rights Reserved.

RICE LAKE WEIGHING SYSTEMS • 230 WEST COLEMAN STREET • RICE LAKE, WISCONSIN 54868 • USA