

---

# TI-500/500E

DIGITAL INDICATOR

---

# SETUP / OPERATION MANUAL

*Transcell Technology inc.*

## Table of Contents

Introduction .....	1
Keyboard Functions.....	1
Installation and Wiring.....	2
Configuration.....	2
Setup Menu Descriptions.....	5
User Menu Descriptions.....	6
Calibration.....	7
APPENDIX A: Specifications.....	11
APPENDIX B: Serial Data Format.....	11
APPENDIX C: Determining Proper Span Gain.....	11
APPENDIX D: Options .....	13

## Introduction

The TI-500 is a general purpose, "no frills" digital indicator housed in a standard black ABS enclosure. It comes standard with a large (.75") LCD screen for easy readout of up to 50,000 display divisions, and supplies enough current for up to 4-350Ω load cells. All setup parameters may be entered via the front panel keys, including calibration.

Its sister indicator, the TI-500E, features a green LED screen for use in poorly lit areas. Function-wise the TI-500E is the same as the TI-500.

The TI-500 uses full duplex RS-232 serial for-

mat for communication with many types of attached support equipment. The unit can transmit data on demand, or continuously in a popular data protocol to match a wide variety of printers, remote displays, or personal computers.

The indicator's setup parameters are altered through the Setup menu while the serial communication parameters are altered through the User menu. The configuration section of the manual, starting on page 2, explains how to use the five front panel keys to maneuver and save settings in both menus.

## Keyboard Functions

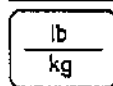

Toggles between lb and kg units if this key is enabled in the User Menu.

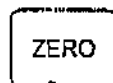

Sets indicator to display "0" when in Gross mode, and within zero band range.



Toggles between Gross and Net weight display.



Used to zero a weight indication in Net mode.



Sends "Print" data to printer if scale is stable and not in overload. Not active when "Continuous" option is selected in User Menu.

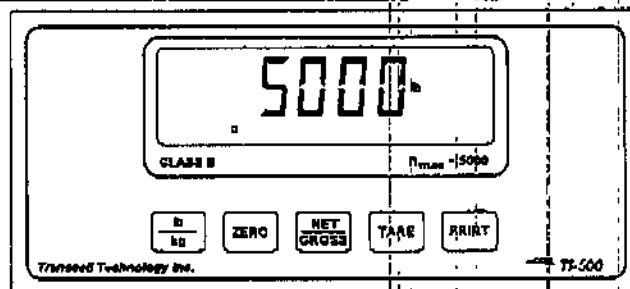

TI-500 FRONT PANEL

## Installation and Wiring

Following is the Installation and Wiring directions for the standard TI-500/500E indicator only. If the indicator was ordered in the stainless steel enclosure, please refer to Appendix D for wiring information.

The TI-500's back cover comes equipped with a female DSUB-9 connector for the RS-232 serial port, a male input jack for DC power, a calibration switch, and a female 14-pin Centronics type connector for input of the 4-wire load cell or junction box cable. A male type 14-pin connector is included with the unit to ease installation.

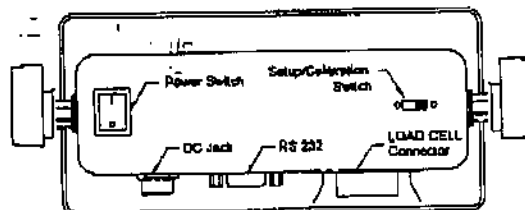

Shown at right are the pin assignments for the female 14-pin load cell connector. Please wire cable to both pins listed to ensure proper operation.

Pin No.	Pin Name
1/8	+Excitation
3/10	-Excitation
5/12	+Signal
7/14	-Signal

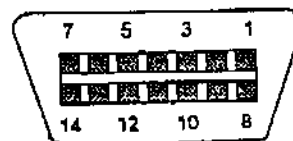

14-pin load cell connector (female)

Shown at right are the pin assignments for the female 9-pin RS-232 connector.

Pin No.	Pin Name
2	Receive Data
3	Transmit Data
5	Signal Ground

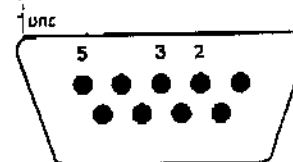

9-pin RS-232 connector (female)

## Configuration

The TI-500 indicator includes two separate menus which contain all of the configurable parameters for the unit. The Setup menu, containing most of the indicator's functional setup parameters, consists of 15 separate menu selections, each with its own sub-menu of choices. The User menu, containing most of the indicator's serial communication parameters, consists of 5 separate menu selections, each also with its

own sub-menu of choices.

To set up the indicator, you must first enter the appropriate menu mode. Once there, four of the front panel keys become directional navigators to move around in the menus, and one key is used to save or SET the selections. Complete directions for the standard indicator start on the next page.

## Configuration / Continued

To place the unit in Setup menu mode:

*Note: If the indicator was ordered in the stainless steel enclosure, please refer to Appendix D for instructions on how to enter setup mode.*

1. Turn the power off to the unit.
2. On back cover, move the Setup / Calibration Switch to opposite position. Turn the indicator back on.
3. The display shows "F1" to indicate that the unit is in Setup menu mode. Shown at right are the directional and SET key assignments.

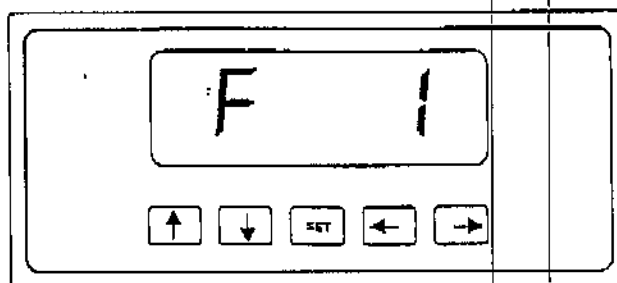

### SETUP MENU CHART

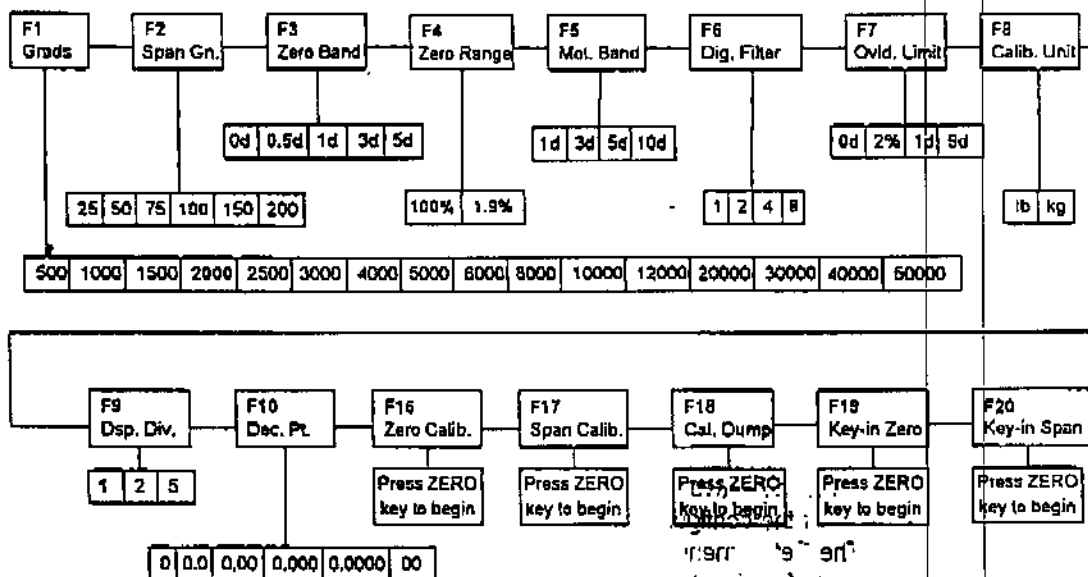

#### Notes on SETUP MENU CHART:

1. Functions F11 to F15 are reserved for future use and do not appear when toggling from F10 to F16.
2. Detailed descriptions of the menu parameters begin on page 5 of this manual.

N B A U

## Configuration / Continued

To place the unit in User menu mode:

1. Turn the power off to the unit.
2. While holding down the lb/kg key, turn the power back on.
3. When the display shows "A1", the unit is in User Menu mode, and you can release the lb/kg key. Shown at right are the directional and SET key assignments

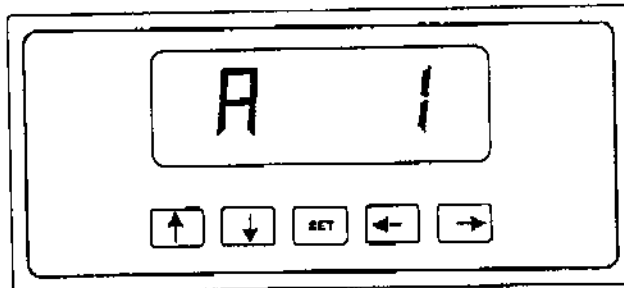

### USER MENU CHART

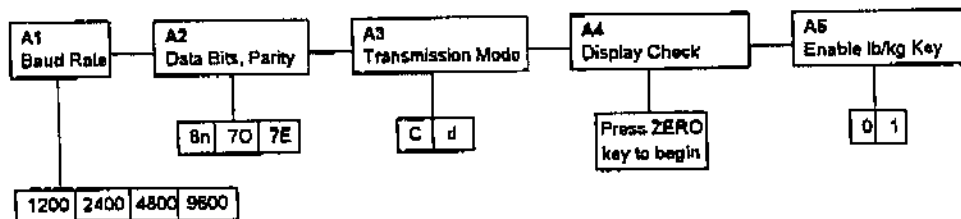

To place the unit back into the Normal Operating mode:

1. Turn off the indicator. If the unit was in Setup menu mode, toggle the Setup/Calibration Switch back to its original position, and turn the indicator on. If the indicator was in User menu mode, just turn the indicator back on without pressing any keys.
2. The display will go through a digit check, then settle into Normal Operating mode.
3. All front panel keys will now return to their normal mode of operation.

### Setup Menu Descriptions

NAME/CODE	DESCRIPTION	CODE/VALUE	
F1 Graduations	Specifies number of full scale graduations. Value should be consistent with legal requirements and environmental limits on the useful system resolution.	500 1,500 2,500 4,000 6,000 10,000 20,000 40,000	1,000 2,000 3,000 5,000√ 8,000 12,000 30,000 50,000
F2 Span Gain	Span Gain is related to A/D integration time. The larger the span gain, the higher the external resolution, but the slower the update speed. See Appendix C for more information.	25 75 150	50√ 100 200
F3 Zero Track Band	Selects the range within which the scale will automatically zero. Note that the scale must be in standstill to automatically zero. Selections are in Display Divisions.	0d 0.5d√ 1d 3d 5d	
F4 Zero Range	Selects the range within which the scale may be zeroed. Note that the indicator must be in standstill to zero the scale.	100%√ 1.9%	
F5 Motion Band	Sets the level at which motion is detected by comparing the present display update with the previous one. If motion is not detected for two seconds or more, scale is in standstill and can process a Print or Zero command. Maximum value varies depending on local regulations.	1d 3d√ 5d 10d	
F6 Digital Filter	Averages weight readings to produce higher accuracy. The higher the filter number, the greater the accuracy but the slower the response time. Choose 4 or 8 unless a very fast response is needed.	1 4	2 8√
F7 Overload Limit	Selects the desired formula which determines the point at which the indicator shows overload ("□□□□"). All selections are based on the primary unit selected in F8.  "FS" = Full scale in primary units.	FS FS + 2%√ FS + 1d FS + 9d	
F8 Calib. Unit	Selects the primary base unit to be used in the calibration process. Also the default unit for normal operation. "1" = primary unit is lb.                      "2" = primary unit is in kg.	1√ 2	
F9 Display Divisions	Determines the desired weight increments. Value should be consistent with legal requirements.	1√ 2 5	
F10 Decimal Pt.	Determines location of the decimal point.	0√ 0.00 0.0000	0.0 0.000 00
F16 Zero Calibration	Places indicator into the zero calibration routine. Scrolling down with the ZERO key one level begins the procedure.	Press ZERO key to begin sequence	

### Setup Menu Descriptions / Continued

NAME/CODE	DESCRIPTION	CODE/VALUE
F17 Span Calibration	Places indicator into the span calibration routine. Scrolling down with the ZERO key one level begins the procedure.	Press ZERO key to begin sequence
F18 Dump Calibration	Actuates the function which allows user to view both the zero and span calibration value. The values displayed in this function are valid only after Calibration (F16 & F17) has been successfully completed. Scrolling down with the ZERO key one level begins the procedure.	Press ZERO key to begin sequence
F19 Key-in Zero	Allows user to key-in known zero calibration value in case of memory loss in the field. Scrolling down with the ZERO key one level begins the procedure.	Press ZERO key to begin sequence
F20 Key-in Span	Allows user to key-in known span calibration value in case of memory loss in the field. Scrolling down with the ZERO key one level begins the procedure.	Press ZERO key to begin sequence

**Notes on Setup Menu Descriptions:**

1. Factory-set defaults are shown in bold with a √.

### User Menu Descriptions

NAME/CODE	DESCRIPTION	CODE/VALUE
A1 Baud Rate	Selects the baud rate for data transmission through the serial port.	1200    2400√ 4800    9600
A2 Data Bits and Parity	Selects the number of data bits and parity of serial transmission. "8n" = 8 data bits with no parity bit "7O" = 7 data bits with odd parity bit "7E" = 7 data bits with even parity bit	8n√ 7O 7E
A3 Mode of Serial Transmission	Selects when data will be sent out of the serial port to a printer or computer: "C" = Continuous mode; send data continuously "d" = Demand mode; send data when a PRINT command is issued from the printer, computer, or indicator.	C√ d
A4 Display Check	Actuates the function which illuminates all digit segments, decimal points, and LCD annunciators in a test sequence. Pressing the ZERO key to scroll down one level begins the test sequence.	Press ZERO key to begin sequence
A5 Disable the lb/kg Key	Allows the lb/kg key to be disabled so that an operator cannot accidentally press the key and change the displayed units. "0" = Disable the lb/kg key      "1" = Enable the lb/kg key	0 1√

**Notes on User Menu Descriptions:**

1. Factory-set defaults are shown in bold with a √.

## Calibration

**Note:** If the indicator was ordered in the stainless steel enclosure, please refer to Appendix D for instructions on how to enter Setup mode.

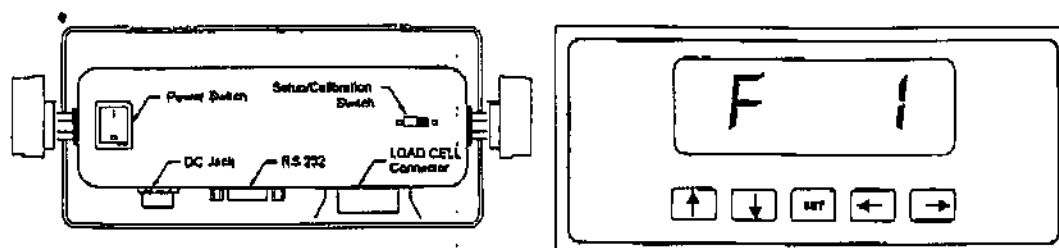

The indicator is calibrated by following the procedures embedded in F16 (Zero) and F17 (Span) of the Setup Menu. Each procedure enters a value into the indicator's non-volatile memory, F16 the zero value (deadweight) and F17 the span value (test weight). The minimum test weight that can be used is 10% of full scale capacity. After the two calibration procedures are executed successfully, the user should record

both calibration values, which can be viewed by entering the F17 "dump" procedure.

In the unlikely event that either value is lost while in the field, the setup menu makes provisions for re-entering these values via F19 and F20, thus eliminating the need for re-calibration with test weights.

**To calibrate the zero point using the F16 zero calibration procedure:**

1. If the unit is not in the Setup mode, enter the Setup mode as follows: Turn the power off to the unit. On the back cover, move the Setup / Calibration Switch to opposite position. When power is re-applied, "F 1" shows on the display. Allow a 20 minute warm-up period for the load cell(s) and indicator to become thermally stable.
2. While in the Setup mode, scroll to "F 16", then scroll down once using the ZERO key to enter zero calibration menu.
3. The display will momentarily show "C 0" followed by a value. After making sure that there are no test weights on the platform, press ZERO to zero the value, then press the NET/GROSS key to save the zero point value.
4. The display will show "EndC0" momentarily, then revert back up to F16. At this time, proceed to the F17 span calibration to complete indicator calibration.



## Calibration / Continued

To calibrate the span using the F17 span calibration procedure:

1. While in the Setup mode, scroll to "F 17", then scroll down once using the ZERO key to enter zero calibration menu.
2. The display will momentarily show "C 1" for the span calibration, followed by a value with one flashing digit. This value will be zero with the Decimal Point parameter selected in F10. Place the test weight on the weighing mechanism.
3. Use the four directional keys (shown at right) to adjust the displayed value to the actual test weight value. Increase the flashing digit by pressing the lb/kg key. Decrease the flashing digit by pressing the ZERO key. The position of the flashing digit may be changed by pressing the PRINT key or the TARE key.
4. After setting the exact value, press the NET/GROSS key to save the value.
5. If the calibration was successful, the display will show "EndC1" momentarily, then revert back up to F17. At this time it is suggested that the calibration values be recorded for future use (see next page).
6. If the calibration was *not* successful, one of the error messages below will appear. Take the indicated action to correct the problem, then perform a new calibration.

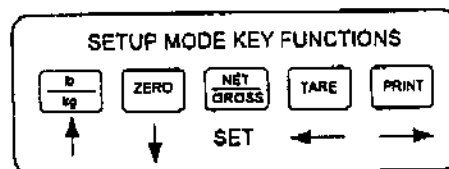

"Err0" - The calibration test weight or the adjusted keyed-in weight is larger than the full capacity of the scale. Change the calibration test weight or check the input data.

"Err1" - The calibration test weight or the adjust keyed-in weight is smaller than 10% of the full capacity of the scale. Change the calibration test weight or check the input data.

"Err2" - The internal resolution of the scale is not high enough to accept the calibration value. Select a larger parameter for the Span Gain (F2).

## Calibration / Continued

To record the calibration values using the F18 Dump Procedure:

**Note:** The values displayed in this procedure are valid only after a successful calibration has been performed using F16 and F17.

1. If the unit is not in the Setup mode, enter the Setup mode as follows: Turn the power off to the unit. On the back cover, move the Setup / Calibration Switch to opposite position. When power is re-applied, "F 1" shows on the display.
2. While in the Setup mode, scroll to "F 18", then scroll down once using the ZERO key to enter dump calibration menu.
3. The display will momentarily show "CAL 0" followed by a value. This value is the zero calibration value and should be recorded in the table below. Press any key to continue.
4. The display will momentarily show "CAL 1" followed by another value. This value is the span calibration value and should also be recorded in the table below. Press any key to return to upper level (F18).

TI-500 INDICATOR	ZERO CALIBRATION VALUE	SPAN CALIBRATION VALUE
S/N:		

TI-500 Calibration Value Table

To key-in the zero calibration value using the F19 Key-in Procedure:

**Note:** This procedure is intended for emergency use only in the case of non-volatile memory loss. A valid zero calibration value, obtained from a successful F16 calibration procedure, must be used.

1. If the unit is not in the Setup mode, enter the Setup mode as follows: Turn the power off to the unit. On the back cover, move the Setup / Calibration Switch to opposite position. When power is re-applied, "F 1" shows on the display.
2. While in the Setup mode, scroll to "F 19", then scroll down once using the ZERO key.
3. The display will momentarily show "CAL 0", followed by a flashing zero. Use the four directional keys (shown at right) to adjust the displayed value to the zero calibration value.

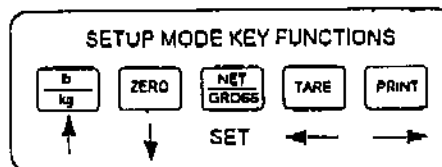

4. After setting the exact value, press the NET/GROSS key to save the value.
5. The display will show "E CAL 0" momentarily, then revert back up to F19.

## Calibration / Continued

To key-in the span calibration value using the F20 Key-in Procedure:

Note: This procedure is intended for emergency use only in the case of non-volatile memory loss. A valid span calibration value, obtained from a successful F17 calibration procedure, must be used.

1. If the unit is not in the Setup mode, enter the Setup mode as follows: Remove power to the unit and carefully remove the back cover. Locate the two-position DIP switch on the main PCB, located near the top edge, and slide switch # 1 to the ON position. When power is re-applied, "F 1" shows on the display.
2. While in the Setup mode, scroll to "F 20", then scroll down once using the ZERO key.
3. The display will momentarily show "CAL 1", followed by a flashing zero. Use the four directional keys (shown at right) to adjust the displayed value to the span calibration value.

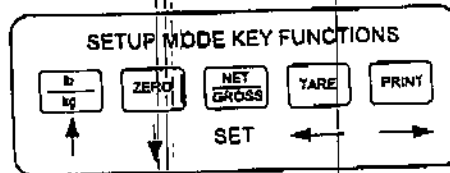

4. After setting the exact value, press the NET/GROSS key to save the value.
5. The display will show "E CAL 1" momentarily, then revert back up to F20.

To place the unit back into the Normal Operating mode:

1. Turn off the indicator. Toggle the Setup/Calibration Switch back to its original position, and turn the indicator back on.
2. The display will go through a digit check, then settle into Normal Operating mode.
3. All front panel keys will now return to their normal mode of operation.

## APPENDIX A: Specifications

---

### ANALOG SPECIFICATIONS

Full Scale Input Signal	30mV, including dead load
Input Impedance	30MΩ, typical
Internal Resolution	Approximately 260,000 counts
Display Resolution	30,000 dd
Measurement Rate	10 Meas/sec, nominal
System Linearity	Within 0.02% of FS
Calibration Method	Software Calibration, with long term storage in EEPROM
Excitation Voltage	+10VDC, 4 x 350Ω load cells

### DIGITAL SPECIFICATIONS

Microcomputer	Intel 80C32
Program Memory:	32K x 8, external to μC
EEPROM:	64 x 16, external to μC
Digital Filtering	Software selectable

### SERIAL COMMUNICATIONS

Serial Port	Full Duplex, 1200, 2400, 4800, 9600 Baud
	8 data bits, no parity
	7 data bits, odd parity
	7 data bits, even parity

### OPERATOR INTERFACE

Display	.75" (19 mm) 7-segment, Liquid Crystal, 5½ Digit
Additional Symbols	Net, Gross, Stable, neg weight
Keyboard	5-key flat membrane panel

### POWER

AC Adapter	12 VDC @ 650mA
Power Consumption	200mA, with 4 x 350Ω Load Cells

### ENVIRONMENTAL

Operating Temperature	-10° to +40° C
Storage Temperature	-25° to +70° C

### MECHANICAL

Overall Dimensions	3.2" x 6.8" x 1.4" (81mm x 173mm x 35mm)
--------------------	--

## APPENDIX B: Serial Data Format

---

The TI-500 Indicator is equipped with a full duplex ASCII compatible RS-232 serial communications terminal wired as a female DSUB-9 type connector mounted on the back cover. As shown, the format provides both Continuous and Demand serial transmission modes.

The Continuous mode is used to interface to computers, scoreboards, and other remote devices requiring constant data updating. The transmission occurs at the end of each display update. Primarily designed to interface to printers, the Demand mode allows control from a host device, usually a PC, and can be activated by pressing the PRINT key on the TI-500 front panel.

## APPENDIX B: Serial Data Format / Continued

### Continuous Mode

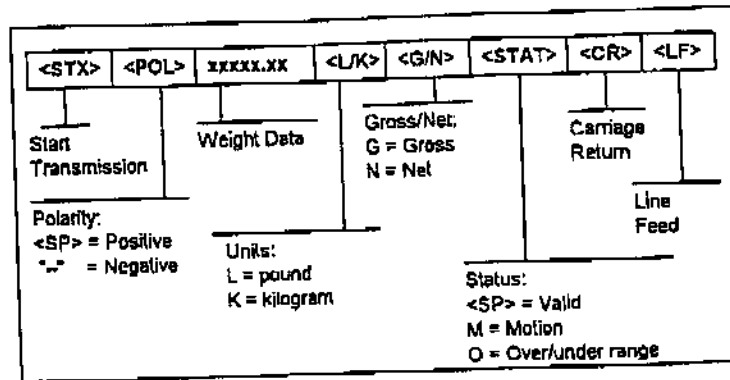

Consolidated Controls Continuous Mode

### Demand Mode

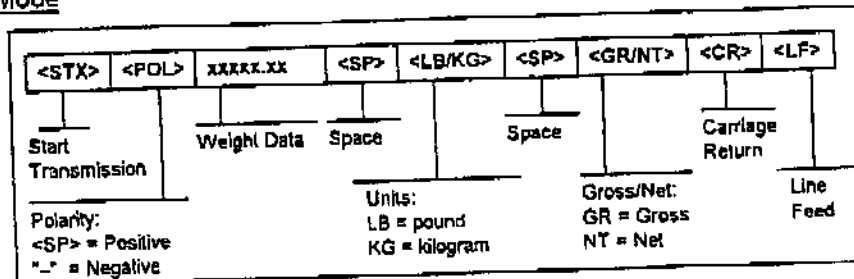

Consolidated Controls Demand Mode

1. Recognized host command(s):

"P" for Print	"Z" to Zero the scale	"T" to Tare the scale
"G" to change to Gross mode	"N" to change to Net mode	"C" to Change displayed units

2. Restrictions for transmission:

"P" Command:

Will not respond if a) scale is in motion; b) positive overload; c) negative overload; d) negative gross weight; or e) scale is in "Display Check Mode".

"Z" Command:

Will not respond if a) scale is in motion; b) scale is not in gross mode; or c) scale is not within Zero Capture Range (F4).

"T" & "G" Command:

Will not respond if a) scale is in motion; or b) scale is not in net mode.

"N" Command:

Will not respond if a) scale is in motion; or b) scale is not in gross mode.  
Will send the "Invalid" format when a) scale is in motion; b) under zero; or c) over capacity.

## APPENDIX C: Determining Proper Span Gain

The Span Gain parameter specified in F2 of the Setup Menu is directly related to the A/D integration time. Therefore, the lower the number, the higher the measurements per second. Disregarding digital filter length, a span gain of 25 produces about 20 to 25 measurements per second, while a span gain of 200 produces only about 3 or 4 measurements per second.

There are two steps to determining the proper

span gain value to use in the Setup Menu for F2. The first involves looking up a value in the table below, saving that value, then calibrating the system.

If the first step does not yield a successful calibration, then the second step allows the technician to view the actual internal count to determine the proper value for the span gain and check the system for linearity.

### To determine the initial value for span gain in the setup menu:

1. Determine the number of desired external graduations and choose the corresponding value under the number closest to your full scale input range in millivolts.
2. Enter the Setup Menu and save this number for the Span Gain parameter in F2.
3. Perform a complete calibration. If the calibration proves unsuccessful, or you wish to view the internal count, proceed to the next set of instructions.

### To view the internal count during the calibration procedure:

1. Enter the zero calibration menu (F16) and follow steps 1 to 3, *but do not save the zero point*.
2. After pressing ZERO to zero the offset, you may place the test weight(s) on the weighing mechanism.
3. The displayed count is the internal count. At full scale, the displayed count should be a minimum of 2 times the desired external graduations. However, for maximum stability, a factor of 5:1 or higher is recommended.
4. If the displayed count is large enough, remove the test weight(s), re-zero the indicator if necessary, and proceed with the calibration. If the displayed number is not large enough, increase the Span Gain to the next highest choice in the Setup Menu and re-calibrate.

# of External Grads	Full Scale Input Range (mV/V)							
	0.25	0.50	0.75	1.00	1.25	1.50	1.75	2.00
500	25	25	25	25	25	25	25	25
1000	50	25	25	25	25	25	25	25
1500	50	25	25	25	25	25	25	25
2000	75	50	25	25	25	25	25	25
2500	100	50	50	25	25	25	25	25
3000	100	50	50	25	25	25	25	25
4000	150	75	50	50	25	25	25	25
5000	200	100	75	50	50	50	25	25
6000	200	100	75	50	50	50	50	25
8000	-	150	100	75	50	50	50	50
10000	-	200	150	100	75	75	50	50
12000	-	200	150	100	75	75	75	50
20000	-	-	-	200	150	150	100	100
30000	-	-	-	-	200	200	150	150

Recommended Minimum (5:1) Span Gain Table

**•APPENDIX D: Options**

**Option A: Stainless Steel Enclosure**

**A) Installation and Wiring**

**OVERVIEW OF TI-500/500E CIRCUIT BOARD**

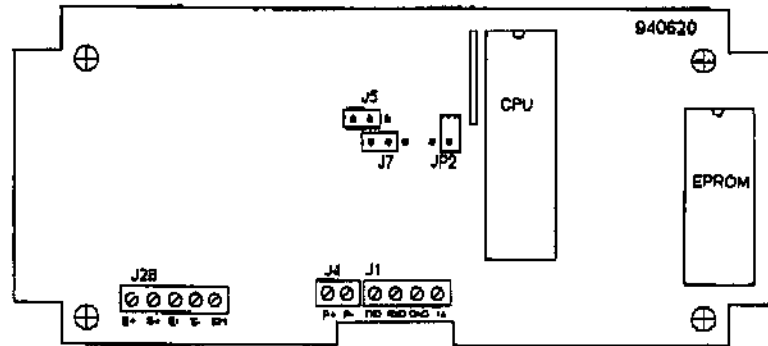

Shown above is an overview of the TI-500/500E Circuit Board showing the major landmarks as well as the terminal blocks used for the various inputs and outputs.

These consist of a Load Cell Feed (pre-wired with 15' cable)(J2B), a DC Power Supply feed (pre-wired) (J4), and a Serial Communications Terminal (J1). The load cell feed cable implements the color code shown at right:

Color	Wiro Name
RED	+Excitation
BLK	-Excitation
GRN	+Signal
WHT	-Signal

**CONNECTING THE SERIAL COMMUNICATIONS CABLE**

Shown at right is a close-up of terminal block J1 which is the Serial Communications Terminal. Make the appropriate connections between this terminal and the serial communications cable.

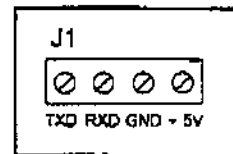

**B) To place the unit in Setup menu mode (refer to circuit board overview shown above):**

1. Turn off power to the unit or unplug the indicator from its power source.
2. Carefully remove the back cover and locate the two-position jumper JP2 on the main PCB. The jumper is located to the left of the CPU.
3. Position the shunt block as shown at right, then re-apply power.



**C) To exit the Setup menu mode (refer to circuit board overview shown above):**

1. With power still applied, position the shunt as shown at right.



## APPENDIX D: Options / Continued

---

### Option B: Remote Display

If interfacing to a Remote Display Unit, the following serial communication parameters must be used:

Baud Rate (A1):	2400
Data Bits & Parity (A2):	8 Data Bits, No Parity
Trans. Mode (A3):	Continuous