

DeckHand™ Portable Scale



Shown with optional ramp.
Indicator sold separately; shown for illustration only.



Measurement
Canada
Approved

(SEE CHART ON BACK OF PAGE FOR PART #'S)

Designed for easy one-person operation, the DeckHand portable floor scale features two large rubber wheels for easy movement on rough floors. Unlike portable scales that rest on four wheels, the DeckHand's wheels only touch the floor when the unit is tilted back for movement. This means the weighing platform remains stable even on uneven floors.

Available in painted steel or stainless steel, these rugged scales stand up to tough conditions. Two opposed off-center load cells provide superior accuracy without the need for leveling feet. IQ plus Series indicators can be easily column-mounted with slight modifications. A mounting bracket for our models IQ plus® 310A, IQ plus® 390-DC, IQ plus® 510, IQ plus® 710, and IQ plus® 800 indicators come standard on the column assembly.

Applications

- General industrial applications
- Rental fleets

Standard Features

- Mild steel or stainless wheeled frame, base, and indicator stand
- 500 lb, 1000 lb, 2000 lb capacity
- Standard indicator mount with integral handles for the IQ plus® 310A, IQ plus® 390-DC, IQ plus® 510, IQ plus® 590, IQ plus® 710, and IQ plus® 800 indicators, painted or stainless steel available
- Large rubber wheels simplify movement on uneven floors
- One-person portability
- RL1260 aluminum load cells

Options/Accessories

- 41292** ... Clam shell for 1260 load cell, stainless steel
- 43376* Ramp assembly, 500/1000 lb
- 43377* Ramp assembly, stainless steel, 500/1000 lb
- 43378* Ramp assembly, 2000 lb
- 43379* Ramp assembly, stainless steel, 2000 lb
- 43978 Additional operating manual

* Ramp sizes = 25" x 27"

** Must order in quantities of two

Optional Indicator Mounts

- 41371 Mounting bracket for IQ 700 IS, stainless steel, 4" x 9.12"
- 41373 Mounting bracket for IQ 700 IS, painted steel, 4" x 9.12"
- 43938 Mounting bracket for CW 80-I, stainless steel, 4" x 7.5"

APPROVALS:

NTEP certified, CC# 98-004, Class III, 2500d;
Measurement Canada approved, AM-5218

END LOAD CAPACITY:

100% end loading

mV/V OUTPUT:

2 mV/V

CABLE LENGTH:

9' 10" (3 m)

HEIGHT:

Weighing platter: 4.5" H when in weigh mode

COLUMN HEIGHT:

59"

WARRANTY:

One year limited warranty

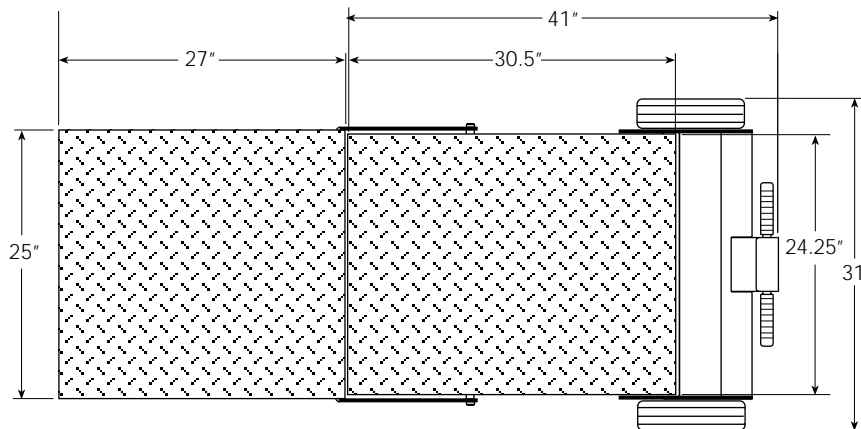
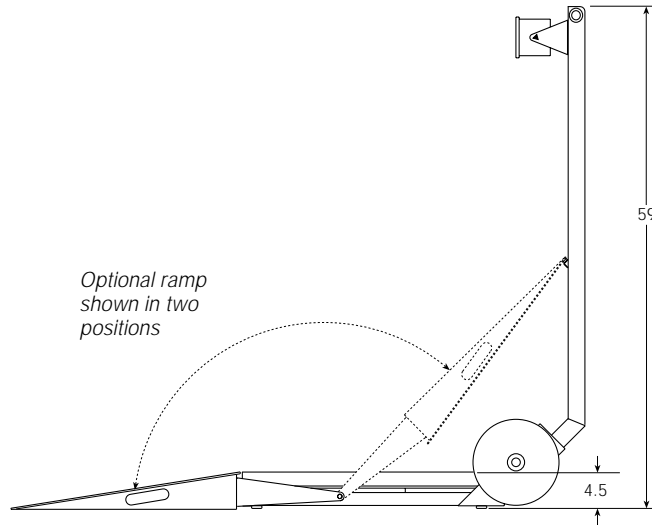

DIMENSIONS

DECKHAND

PART #	MODEL	OVERALL SIZE (W x L x H)	CAPACITY LB (KG)	APPROXIMATE SHIP WEIGHT LB (KG)	APPROXIMATE SHIP WEIGHT LB (KG)
41293	DH-500	31" x 41" x 4.5"	500 lb (226.8 kg)	336 lb (152 kg)	380 lb (172 kg) w/ramp & indicator
41294	DH-1000	31" x 41" x 4.5"	1000 lb (453.6 kg)	356 lb (161 kg)	400 lb (181 kg) w/ramp & indicator
41295	DH-2000	31" x 41" x 4.5"	2000 lb (907.2 kg)	373 lb (169 kg)	430 lb (195 kg) w/ramp & indicator
41296*	DH-500	31" x 41" x 4.5"	500 lb (226.8 kg)	336 lb (152 kg)	380 lb (172 kg) w/ramp & indicator
41297*	DH-1000	31" x 41" x 4.5"	1000 lb (453.6 kg)	356 lb (161 kg)	400 lb (181 kg) w/ramp & indicator
41298*	DH-2000	31" x 41" x 4.5"	2000 lb (907.2 kg)	373 lb (169 kg)	430 lb (195 kg) w/ramp & indicator

* Stainless steel